

SIRCO MC PV

Disconnect switches for photovoltaic applications
up to 45 A, up to 1000 Vdc
UL 508i & IEC 60947-3

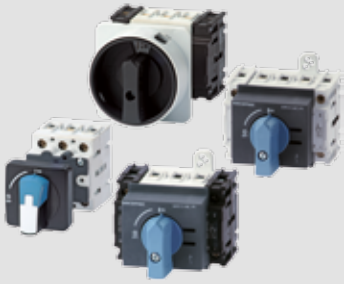

Your guarantee for safe & reliable switching of photovoltaic circuits

Taking into account the specificity and technical constraints of solar applications, SOCOMEC was the first manufacturer to release real PV-specific disconnect switches certified by UL, according to UL98B. The SIRCO MC PV follow the same trend and are tested according to the latest industry standards.

Our complete range of PV disconnect switches is fully tested and certified according to the relevant standard for PV applications; this is our commitment to quality and performance.



SITE 645 A

Save time

Multiple mounting options **facilitate easy integration** into standard off the shelf enclosures or your custom designs.

Save space

The compact design ensures the **optimum use** of valuable space in the PV inverter or associated local enclosure.

Rationalize your equipments

The same product can be used to ensure that your standard design **conforms to all major international standards and approvals** including UL, IEC and CCC.



To find out more

Visit our website;

www.socomec.fr/en/sircomcpv



FLC04URL 026 A GB

SIRCO MC PV

UL and IEC Disconnect switches for photovoltaic applications
From 25 to 45 A – 600 & 1000 Vdc

Specifically designed for photovoltaic applications, the SIRCO MC PV disconnect switches **have been tested for use in applications with high performance characteristics** that exceed the requirements of the latest industry standards.

Thanks to its very small size, the **space constraint is largely reduced**, which will allow the usage of much smaller enclosures.

The versatility of the solution, both in terms of installation possibilities and switching options, will make the **SIRCO MC PV fit perfectly in your photovoltaic application.**



SOCOMEK, your best asset

SOCOMEK is an industrial group specialized in the availability, control and safety of low voltage electrical energy which meets the requirements of the industry and service sectors.

As a manufacturer with complete control over its technological processes, SOCOMEK is constantly improving its fields of expertise in order to offer its clients increasingly customised and appropriate solutions.

As a recognized world leader in photovoltaic applications, SOCOMEK is offering you a full range of PV disconnect switches perfectly adapted to your needs.

**ENERGY
SPECIALIST**
SINCE 1922



The advantages of **SIRCO MC PV**

Several switching options

- Multiple circuit



Due to its high performance the product for 2 circuits (2 MPPT, Multiple Power Points Tracking) allows the current interruption of two strings under higher voltage using a single compact switch. This improves ergonomics, reduces overall product size, and improves safety.

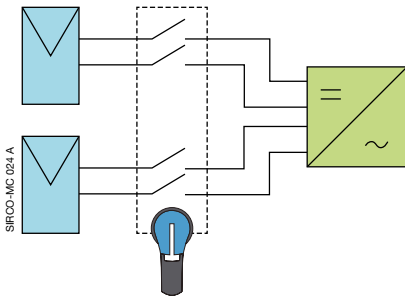

2MPPT switch, 2 circuits are switched together.

- Completely isolate the inverter within one operation



One single device can switch both DC and AC circuits, reducing the overall need for space within the inverter and allowing a voltage free maintenance of the inverter.

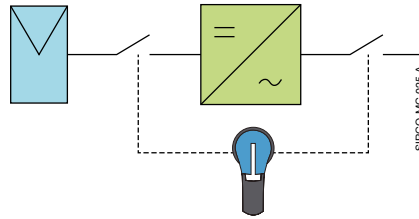

DC and AC circuits are switched with one handle.

- For grounded or ungrounded networks

It is possible to use the SIRCO MC PV in both network systems, either switching one single polarity or both polarities.

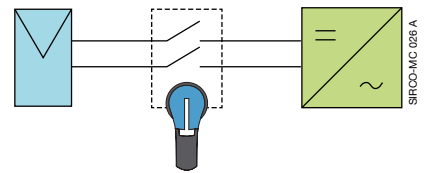

Ungrounded system, both polarities are switched.

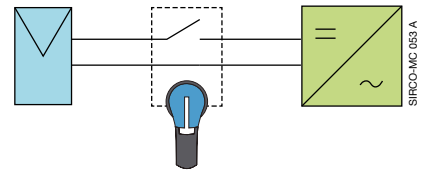

Grounded system, only one polarity is switched.

Enclosed SIRCO MC PV

SIRCO MC PV is also available in non metallic polycarbonate 4x enclosure.



NEC and photovoltaic



Most of the PV systems fall under the provisions of the National Electrical Code (NEC). The requirement for

disconnects for PV systems are covered in Article 690 of the National Electrical Code. NEC limits one and two family dwellings, with certain limitations, to 600 V. Other installations with maximum photovoltaic system voltage over 600

Vdc shall comply with Article 690, Part IX. However, if the most common voltage is still below 600 Vdc, the trend is for higher voltage in order to improve the efficiency of the system.

Various mounting options

• Base mounting

The SIRCO MC PV exists for back plate mounting by means of screws and on DIN rail. This mounting enables quick and efficient installation.

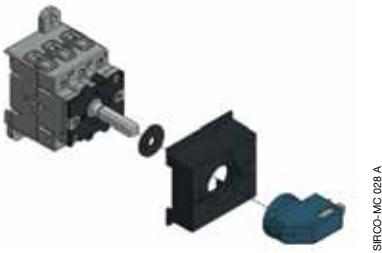

Direct operation

The handle is mounted directly on the switch which can only be operated when the door is open. Modular 45 mm cutout enables integration in modular type panels. The switch must be located behind a hinged cover.



External dead front handle

The handle is mounted on the door and is connected to the switch when the door is closed.

• Panel mounting

The switches can be mounted on the door without tools. The switch body is attached to the inside of the enclosure door.



Quickfix

Once the handle is fitted on the door by means of a nut, handle and switches are assembled through a quarter turn fixation.

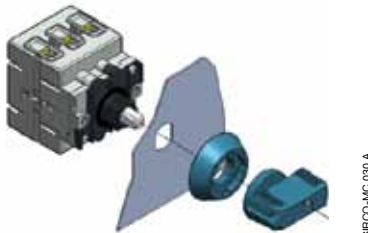

Standard door mounting

This type of mounting is a cost effective and simple solution. The switch is fixed using a nut on the external side of the door.

The standards for PV disconnect switches

USA

- UL98B; Disconnect switches for photovoltaic systems, usually for rating above 40 A.
- UL508i; Manual disconnect switches for photovoltaic systems, usually for ratings up to 40 A.
- UL1741; Inverters and interconnection system equipment.

Worldwide

- IEC 60947; Low-voltage switchgear and controlgear. Part 3; Switches, disconnectors, switch-disconnectors and fuse-combination units.



Space saving

The compact design ensures the optimum use of valuable enclosure space. The SIRCO MC PV is easy to install in the

modern small photovoltaic inverter where space means cost and competitiveness.

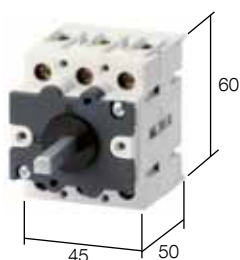

Base mounting.



Panel mounting.

The selection guide

Which standard ?

How many circuits ?

Which voltage ?

Which rating ?

SIRCO MC PV Solar Disconnect Switch

UL 508i							
NUMBER OF CIRCUITS	VOLTAGE VDC	20 A		32 A		45 A	
		DIMENSIONS (mm)	REFERENCES	DIMENSIONS (mm)	REFERENCES	DIMENSIONS (mm)	REFERENCES
1 CIRCUIT	600 Vdc		21PV 2102		21PV 4144		21PV 4144
	1000 Vdc	-	-	-	-	-	-
2 CIRCUITS	600 Vdc		21PV 5102		21PV 8144		21PV 8144
	1000 Vdc	-	-	-	-	-	-
3 CIRCUITS	600 Vdc	Consult us					
	1000 Vdc						

IEC 60947-3							
NUMBER OF CIRCUITS	VOLTAGE VDC	25 A		30 A		40 A	
		DIMENSIONS (mm)	REFERENCES	DIMENSIONS (mm)	REFERENCES	DIMENSIONS (mm)	REFERENCES
1 CIRCUIT	600 Vdc		21PV 2102		21PV 2102		21PV 3124
	1000 Vdc		21PV 3722	-	-		21PV 4754
2 CIRCUITS	600 Vdc		21PV 5102		21PV 5102		21PV 6124
	1000 Vdc		21PV 6722	-	-		21PV 8154
3 CIRCUITS	600 Vdc	Consult us					
	1000 Vdc						

All references are for back plate / DIN rail mounting and ungrounded systems (2 polarities switched). Door mounting and grounded system (1 polarity switched) references are also available, please contact us.

Handles & accessories

Direct operation

SWITCH MOUNTING	TYPE	COLOUR	REFERENCES
Back plate / DIN rail	MC01	Black	2119 1012

External operation

SWITCH MOUNTING	HANDLE			SHAFT		ACCESSORIES	
	TYPE	COLOUR	REFERENCES	SHAFT REFERENCES	LENGHT (switch + shaft)	AUXILIARY CONTACT (NO+NC)	BRIDGING BAR (10 pcs)
Back plate / DIN rail	MC1	Black	2119 3312	2107 0517 ⁽¹⁾	265 mm	2119 0001	2109 0005 ⁽²⁾
		Red / yellow	2119 3313				
	S00 ⁽³⁾	Black	147D 1111				
		Red / yellow	147E 1111				

(1) With door interlock. (2) To switch single polarity, a bridging bar shall be added on the product. Please consult us on UL/IEC connection of ungrounded systems.

(3) IEC only.

The *SIRCO* range

A complete offer for the photovoltaic applications from 16 A to 2500 A

As experts in the solar energy equipment field, SOCOMEC has the specialized know-how for implementing key strategic functions in PV facilities, including safety, through specially designed switch disconnectors to interrupt the DC current generated by solar panels regardless of the facility configuration and operating conditions.

Typical electrical distribution of a residential installation

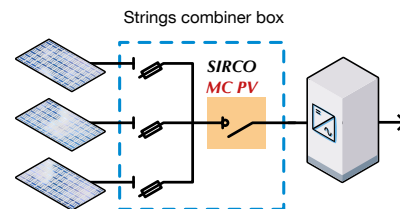

SIRCO-MC 056 A GB

Typical electrical distribution of a large PV installation

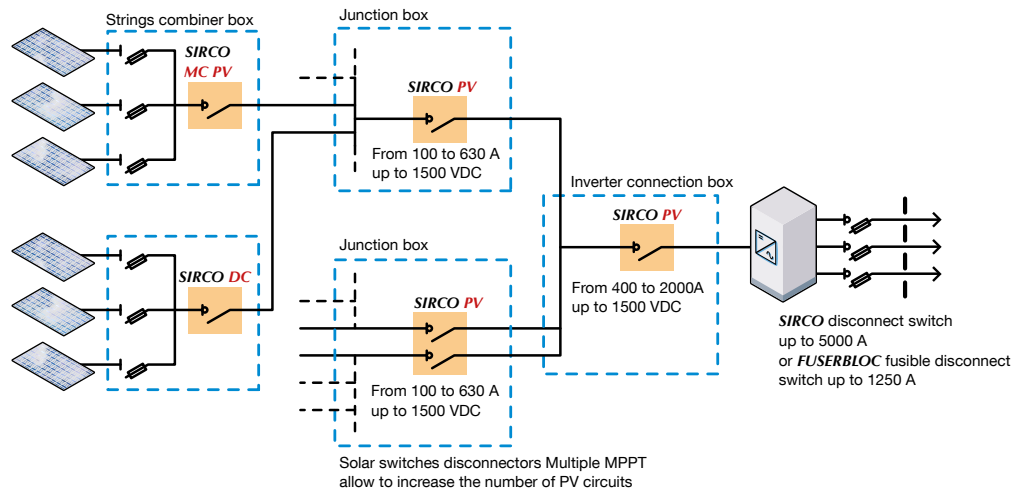

SIRCO-MC 056 A GB

Also available

SIRCO DC PV up to 2500 A

SIRCO DC disconnect switches are heavy duty switches that break and make up to 1500 Vdc photovoltaic circuits on load.

They are suitable for use in accordance with NEC Article 690 photovoltaic installations and Application UL1741.

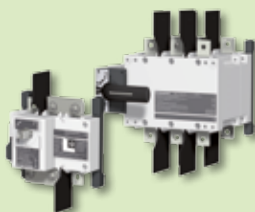

GAMME 154 A

Other UL products

- SIRCO M; Manual motor controller from 16 to 80A
- SIRCO; AC disconnect switches from 30 to 1200A
- FUSERBLOC; Fusible disconnect switches from 30 to 800A
- SIRCOVER; Manual transfer switches from 100 to 1200A
- DIRIS; Multi function metering devices



GAMME 130 C

Socomec worldwide

IN EUROPE

BELGIUM

UPS / Power Control & Energy Efficiency / Solar

Tel. +32 2 340 02 30
Fax +32 2 346 28 99
info.be@socomec.com

FRANCE

UPS / Power Control & Energy Efficiency / Solar

Tel. +33 1 45 14 63 00
Fax +33 1 48 67 31 12
dcm.ups.fr@socomec.com

GERMANY

Power Control & Energy Efficiency

Tel. +49 7243 65292 0
Fax +49 7243 65292 13
info.scp.de@socomec.com

UPS

Tel. +49 621 71 68 40
Fax +49 621 71 68 444
info.ups.de@socomec.com

ITALY

Power Control & Energy Efficiency

Tel. +39 02 98 49 821
Fax +39 02 98 24 33 10
info.scp.it@socomec.com

Solar

Tel. +39 0444 598611
Fax +39 0444 598627
info.solar.it@socomec.com

UPS

Tel. +39 02 98 242 942
Fax +39 02 98 240 723
info.ups.it@socomec.com

NETHERLANDS

UPS / Power Control & Energy Efficiency / Solar

Tel. +31 30 760 0900
Fax +31 30 637 2166
info.nl@socomec.com

POLAND

Power Control & Energy Efficiency

Tel. +48 91 442 64 11
Fax +48 91 442 64 19
info.scp.pl@socomec.com

UPS

Tel. +48 22 825 73 60
Fax. +48 22 825 73 60
info.ups.pl@socomec.com

PORTUGAL

UPS / Solar

Tel. +351 261 812 599
Fax +351 261 812 570
info.ups.pt@socomec.com

ROMANIA

UPS / Power Control & Energy Efficiency / Solar

Tel. +40 21 319 36 88
Fax +40 21 319 36 89
info.ro@socomec.com

RUSSIA

UPS / Power Control & Energy Efficiency / Solar

Tel. +7 495 775 19 85
Fax +7 495 775 19 85
info.ru@socomec.com

SLOVENIA

UPS / Power Control & Energy Efficiency / Solar

Tel. +386 1 5807 860
Fax +386 1 561 11 73
info.si@socomec.com

SPAIN

UPS / Power Control & Energy Efficiency / Solar

Tel. +34 93 540 75 75
Fax +34 93 540 75 76
info.es@socomec.com

UNITED KINGDOM

Power Control & Energy Efficiency

Tel. +44 1462 440 033
Fax +44 1462 431 143
info.scp.uk@socomec.com

UPS

Tel. +44 1285 863 300
Fax +44 1285 862 304
info.ups.uk@socomec.com

TURKEY

UPS / Power Control & Energy Efficiency / Solar

Tel. +90 216 540 71 20-21-22
Fax +90 216 540 71 27
info.tr@socomec.com

IN ASIA PACIFIC

AUSTRALIA

UPS

Tel. +61 2 9325 3900
Fax +61 2 9888 9544
info.ups.au@socomec.com

CHINA

UPS / Power Control & Energy Efficiency

Tel. +86 21 52 98 95 55
Fax +86 21 62 28 34 68
info.cn@socomec.com

INDIA

Power Control & Energy Efficiency

Tel. +91 124 4027210
Fax +91 124 4562738
info.scp.in@socomec.com

UPS / Solar

Tel. +91 44 39215400
Fax +91 44 39215450 & 51
info.ups.in@socomec.com
info.solar.in@socomec.com

SINGAPORE

UPS / Power Control & Energy Efficiency

Tel. +65 6506 7600
Fax +65 64 58 7377
info.sg@socomec.com

THAILAND

UPS

Tel. +66 2 941 1644 7
Fax +66 2 941 1650
info.ups.th@socomec.com

VIETNAM

UPS

Tel. +84 8 3559 1220
Fax +84 8 3559 1221
info.ups.vn@socomec.com

IN MIDDLE EAST

UNITED ARAB EMIRATES

UPS / Power Control & Energy Efficiency / Solar

Tel. +971 4 29 98 441
Fax +971 4 29 98 449
info.ae@socomec.com

IN AMERICA

USA, CANADA & MEXICO

Power Control & Energy Efficiency

Tel. +1 617 245 0447
Fax +1 617 245 0437
info.us@socomec.com

OTHER COUNTRIES

NORTH AFRICA

Algeria / Morocco / Tunisia
info.naf@socomec.com

AFRICA

Other countries
info.africa@socomec.com

SOUTH EUROPE

Cyprus / Greece / Israel / Malta
info.se@socomec.com

SOUTH AMERICA

Tel. +34 93 540 75 75
info.es@socomec.com

MORE DETAILS

www.socomec.com/worldwide

HEAD OFFICE

SOCOMECS GROUP

S.A. SOCOMECS capital 10 816 800€
R.C.S. Strasbourg B 548 500 149
B.P. 60010 - 1, rue de Westhouse
F-67235 Benfeld Cedex - FRANCE
Tel. +33 3 88 57 41 41
Fax +33 3 88 74 08 00
info.scp.isd@socomec.com

www.socomec.com

YOUR DISTRIBUTOR

