

Small Wheel Loaders



Aggregate Handler Arrangements



	926M Aggregate Handler	930M Aggregate Handler	938M Aggregate Handler
Engine Model	Cat® C7.1	Cat C7.1	Cat C7.1
Maximum Rated Gross Power:			
ISO 14396	114 kW (153 hp)	125 kW (168 hp)	140 kW (188 hp)
ISO 14396 (DIN)	116 kW (155 hp)	127 kW (170 hp)	142 kW (190 hp)
Bucket Capacity	3.0-5.0 m ³ (3.9-6.5 yd ³)	3.0-5.0 m ³ (3.9-6.5 yd ³)	3.0-5.0 m ³ (3.9-6.5 yd ³)
Full Turn Tip Load	7870 kg (17,350 lb)*	9255 kg (20,403 lb)*	10 399 kg (22,926 lb)**
Operating Weight	13 270 kg (29,256 lb)*	14 562 kg (32,103 lb)*	16 997 kg (37,473 lb)**

*Aggregate Handler machine equipped with side guards and roading fenders.

**Aggregate Handler machine equipped with side guards, roading fenders and 23.5" R25 tires.

Making Your Choice Easy

Application Specific Configuration

Maximize productivity while keeping operating costs low. Cat Aggregate Handlers are built for sand and gravel applications to maximize profits.

Efficiently Powerful

Experience Hybrid like, industry leading, fuel efficiency with an intelligent hydrostatic power train. For highest production work, a new Performance Mode will boost the power and hydraulic speed in all ranges to get the job done even quicker.

Work Made Easy

Move more with the Caterpillar patented quick loading Performance Series buckets and optimized Z-bar linkage which has been enhanced to maximize visibility. Multi-function work has never been easier with dedicated pumps and a flow sharing implement valve.

Enjoy All Day Comfort

Have a seat in the M Series Small Wheel Loader and enjoy whisper quiet sound levels, all around visibility and seat mounted joystick controls. The large spacious cab combined with the Caterpillar advanced hydraulic cylinder dampening make this the most comfortable seat on your job site.

Customize Your Experience

Modify individual preferences with the Caterpillar industry first Power Train Modes. Fine tune machine performance with adjustments at your fingertips through the soft touch buttons and optional secondary display.

Contents

Application Specific Configuration	4
Customize Your Experience	5
Efficiently Powerful.....	6
Work Made Easy	8
Enjoy All Day Comfort.....	10
Configured for Success	12
Service.....	13
Customer Support.....	13
Aggregate Handler Specifications	14
Bucket Specifications	18
Bucket Selection Tables	20
Operating Specifications	21
Supplemental Specifications	22
Standard Equipment.....	24
Optional Equipment.....	25
Notes.....	26



Environmental and customer friendly –
up to 95% recyclable content by weight



The Cat 926M, 930M and 938M Aggregate Handlers set a new standard for productivity, fuel efficiency and comfort. A high torque, low speed C7.1 engine works in concert with an intelligent hystat power train to deliver fuel efficiency as standard. The optimized Z-bar loader linkage combined with long wear life Performance Series buckets delivers improved payloads and bucket longevity. Extremely low sound levels, large spacious cab and intuitive controls keep you working comfortably all day and even all night! Experience the new industry benchmark.

Application Specific Configuration

Maximize performance and productivity while minimizing operating costs.



Increased Payload

Additional counterweight improves stability without reducing ground clearance or departure angle to maximize performance.

Long Life Sand and Gravel Buckets

Performance Series Buckets deliver higher fill factors and better material retention for significant productivity and fuel efficiency improvements. The buckets feature a long floor, open throat, curved side bars and additional serviceable wear plates including corner guards.

Protect your Power Train

Increase your fording depths with optional elevated breathers. Remote mounted high on the machine for the front and rear axles and hydrostatic gear box. Allows settling pond clean out without contamination.





Customize Your Experience

Make it yours.

Work as one with your machine by customizing the controls.

Flexible Power Train

A smooth, stepless electronically controlled hydrostatic transmission provides adjustable power to the ground with excellent groundspeed control and customizable feel.

- **Select your Power Train Mode:**

- Torque Converter (TC) for smooth rollout.
- Hystat for aggressive hydraulic braking.
- Default mode which blends the best of Hystat and Torque Converter characteristics.

- **Reduce tire wear** using Rimpull control which enables you to match available tractive power to underfoot conditions.
- **Set Directional Shift Response**, soft and smooth for material handling applications or sharp for aggressive operation.



Adjustable Electro Hydraulic Controls

Easily customize the hydraulic performance through secondary display to optimize your efficiency.

- **Optimize hydraulic modulation** with Fine Mode control when working with forks.
- **Quicker hydraulic response** for fine grading at speed and quick functions through Lift and Tilt response settings.
- **Fully adjustable ride control** activation speed along with 3rd function auxiliary flow for powering a broom.

Operator Profiles and Coded Start

- The M Series Wheel Loaders remember your personal settings with unique operator codes to make this machine truly yours and keep it secure on the job site.

Efficiently Powerful

Experience hybrid like fuel efficiency with more power when you need it.



Intelligent Power Management

The Caterpillar exclusive Intelligent Power Management system monitors operator input and power availability to keep the machine working at peak efficiency.

Power on Demand

A choice of Power Modes allows you to choose between maximum fuel efficiency or boosted power along with increased hydraulic speed to get your job done faster.



Standard Power Mode

- Saves up to 10% fuel while running at an efficient 1,600 rpm.
- Recommended for load and carry to maximize fuel efficiency.
- Power-by-range logic increases power in speed Range 4 automatically to maximize travel speed and grade climbing performance.
- Reduces cab sound levels down to a whisper quiet 64 dB(A) typical.
- Improved 930M standard power mode comes with a 5% horsepower boost when compared to earlier M Series models.

Performance Power Mode

- Enabled at the push of a button (HP+)
- Boosts engine power by up to 10% in all speed ranges.
- Boosts engine speed by over 12%.
- Increases hydraulic cycle times and productivity.

Six Cylinders of Efficient Power

The Cat C7.1 engine provides cleaner, quieter operation while delivering superior performance and durability through a high torque, low speed design with a Clean Emissions Module that is designed to manage itself so you can concentrate on your work.

- **No downtime for regeneration** with a passive low temperature system that keeps you on the job.
- **Fit for Life Diesel Particulate Filter** that is designed to exceed the engine overhaul life.
- **Extended fluid fill intervals** with minimal use of Diesel Exhaust Fluid (DEF) with up to four fuel tank fills per DEF fill.
- **Configurable auto idle shut down** based on time and ambient temperature to further reduce fuel burn and keep operating costs low.



Power to the Ground

Lock up and go with fully locking front differential axle that can be engaged on the move at full torque with the pull of a trigger on the seat mounted joystick. Maximize your traction with optional Limited Slip Differential on the rear axle to keep you climbing.

Independent service brakes on front and rear axles provide robust stopping performance while a push button electronic park brake allows you to safely secure the machine with ease.

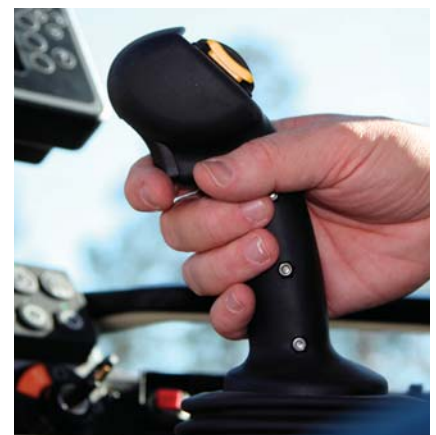



Work Made Easy

Getting the job done.



Optimized Z-bar Linkage

The Caterpillar patented and optimized Z-bar linkage combines the digging efficiency of a traditional Z-bar with integrated tool carrier capabilities for great performance and versatility.

- **Perfect Parallelism** functionality available in Fork Mode gives truly predictable performance while high tilt forces throughout the working range help you safely and confidently handle loads with precise control.
- **Visibility** has been maximized with the introduction of Gen III lift arms which bring a Cast Torque tube resulting in class leading front visibility when combined with the new cast couplers.*
- **Enhanced coupler** options, new ISO or Fusion Cast Couplers offer improved visibility of up to 100% when compared with previous plates style couplers.

**New lift arms only available on standard lift 930M and 938M.*

Quick Loading, Performance Series Buckets

Performance Series Sand and Gravel Buckets deliver up to 10% higher fill factors and better material retention for significant productivity and fuel efficiency improvements. The buckets feature a longer floor to take a bigger bite of the pile, an open throat to heap higher and curved side bars to help with material retention. Wear plates on the sides and bottom maximize bucket life in abrasive aggregate rehandling applications.



Smooth and Predictable Multi-Function Performance

M Series machines feature an electro-hydraulic control system that is governed by the Intelligent Power Management system for peak efficiency. The load-sensing, variable flow system senses work demand and adjusts flow and pressure to match the operators request.

- **Multi-Function without compromise** through the Caterpillar exclusive dedicated hydraulic systems featuring three pumps.
 - 1st pump for Intelligent Hydrostatic drive
 - 2nd pump for implements
 - 3rd pump for steering system

Drive, lift and steer simultaneously with smooth, predictable control. The M Series simply does what you ask it to.

- **Programmable in-cab kick-outs** are easy to set on the go for tilt, lower and lift. This feature is ideal for applications where the work cycle is repeatable allowing you to quickly return to programmed set points and to significantly reduce operator fatigue and work tool or cutting edge wear.
- **Fine tune hydro-mechanical performance** with fully adjustable 3rd and 4th function flow through the secondary display (when equipped) for a perfect marriage between machine and attachments.





Enjoy All Day Comfort

Best seat on the job site.

Have a Seat and Experience:

- **Seat-mounted controls** featuring a low effort joystick for lift and tilt functions along with integrated Forward/Neutral/Reverse switch, differential lock trigger and optional third and fourth auxiliary functions.
- **Superior all around visibility** with single piece front windshield, new parabolic external mirrors, redesigned Generation III linkage and clean hydraulic lines routing.
- **Automatic climate control** with heated rear glass and external mirrors for a quick defrost.
- **Fully adjustable controls** including steering column, joystick and seat suspension.
- **Information at a glance** with large primary LCD display and full color secondary display.
- **An extra eye on the job site** with optional integrated rear object detection and optional* camera systems.
- **A heated and cooled seat** option for added comfort in a wide range of climates.

**Rear camera standard in Europe; Front camera may be required for local EU requirements. Consult your local Cat dealer for additional information.*





An easy day at work with:

- **A spacious, safe, quiet operator environment** featuring ergonomic controls, seat belt notification and optional Bluetooth radio with integrated microphone plus an auxiliary port.
- **Easy access to vital machine parameters** with the optional secondary display, working in conjunction with the standard soft touch panel to allow real time adjustments to machine features and an integrated help button with over 25 languages.
- **Comfortable soft stops** at cylinder end stroke conditions and programmable kickout points with the Caterpillar exclusive electro-hydraulic cylinder snubbing.
- **An even smoother ride** with optional Ride Control when working unloaded and loaded with excellent material retention.
- **Early starts and late finishes** are made easier with optional LED lighting package that includes engine compartment lighting to illuminate the way for checking oil, and coolant level along with refueling the machine in dark conditions.



Configured for Success

Ready to work for you.

The Way You Want It

A complete range of optional equipment and work tools give you the versatility to configure an Aggregate Handler to be successful in your business. Get with your Cat dealer to configure yours.

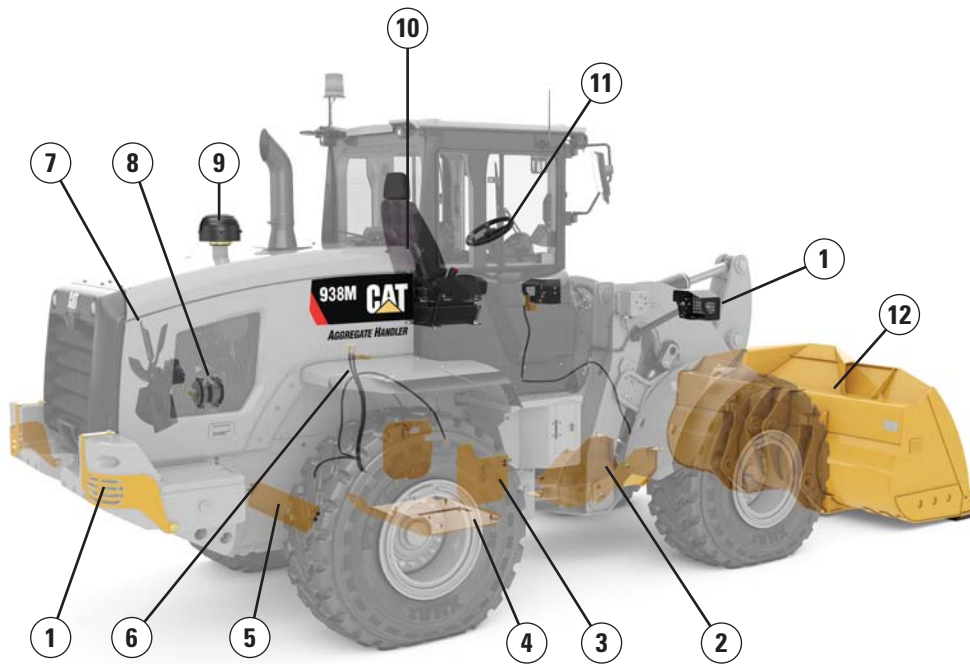

Guards:

- 1) Lights
- 2) Drive shaft
- 3) Side power train
- 4) Lower power train
- 5) Crank case

Debris Packages:

- 6) Elevated breathers: axles and gear box
- 7) Reversing fan
- 8) Sealed alternator
- 9) Turbine precleaner

Operator Environment:

- 10) Seat, deluxe or premium
- 11) Quick steer
- 13) Deluxe cab (with display)

Work Tools

- 12) Full range of tools

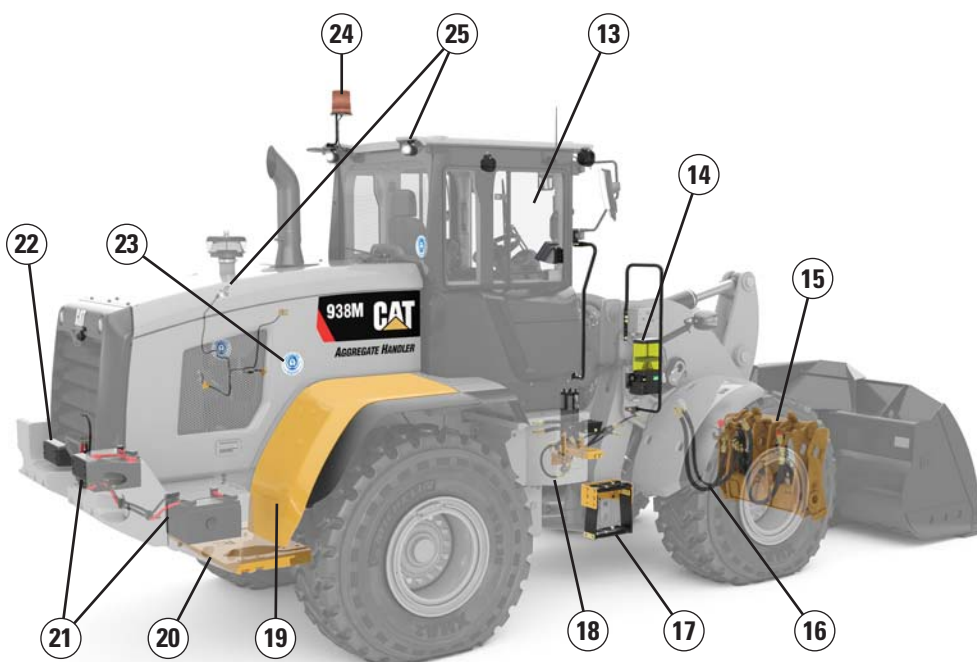

Other Options:

- 14) Autolube
- 15) Coupler: Fusion™ and ISO
- 16) Auxiliary hydraulics: 3rd and 4th
- 17) Windshield washing platform
- 18) Ride Control
- 19) Fenders: extended and full coverage
- 20) Aggregate weight set
- 21) Cold start package
- 22) Rear object detection
- 23) Blue Angel certification
- 24) Beacon
- 25) LED auxiliary lights

Service

Schedule your downtime to maximize your up time.

Get up and running quickly with ground level, daily service access and optional engine compartment lighting. Three large service doors can be opened and closed in any order to give full access to filters and service points. Extended service intervals on hydraulic and power train filters reduce service time and maximize uptime. Additional service features include:

- **Product Link™ PRO standard** with three year subscription to VisionLink®.
- **Maintenance reminders** through secondary display at scheduled intervals.
- **Fit for Life Diesel Particulate Filter** that is designed to exceed the engine overhaul life.
- **Quick fuel filter service** with the Caterpillar exclusive electric fuel priming pump.
- **Jump start studs** as standard equipment.
- **Extended cleanouts** with single plane cooling system and wide spaced 6 fins per inch coolers as standard.
- **Integrated Autolube** (optional) with adjustable greasing frequency.



Customer Support

Unmatched service makes the difference.



Renowned Cat Dealer Support

Rely on your Cat dealer to help you every step of the way with new or used machine sales, rental or rebuild options to meet your business needs.

Maximize your machine uptime with unsurpassed worldwide parts availability, trained technicians and customer support agreements.

Let us earn your business. Experience an M Series Small Wheel Loader and join the Caterpillar family.

Small Wheel Loaders Aggregate Handler Specifications

Engine

Power Mode	926M				930M				938M			
	Cat C7.1**				Cat C7.1***				Cat C7.1***			
	Performance (HP+) Range 1-4		Standard Range 1-3*		Performance (HP+) Range 1-4		Standard Range 1-3*		Performance (HP+) Range 1-4		Standard Range 1-3*	
	kW	hp	kW	hp	kW	hp	kW	hp	kW	hp	kW	hp
Maximum Rated Gross Power												
Maximum Engine Speed												
ISO 14396												
ISO 14396 (DIN)												
Rated Net Power												
SAE J1349 at Minimum Fan Speed												
ISO 9249 (1977)/EEC 80/1269 at Minimum Fan Speed												
ISO 9249 (DIN) at Minimum Fan Speed												
Maximum Gross Torque	N-m	lbf-ft	N-m	lbf-ft	N-m	lbf-ft	N-m	lbf-ft	N-m	lbf-ft	N-m	lbf-ft
ISO 14396												
Maximum Net Torque												
SAE J1349												
ISO 9249:2007												
Displacement	7.01 L		427 in ³		7.01 L		427 in ³		7.01 L		427 in ³	
Bore	105 mm		4 in		105 mm		4 in		105 mm		4 in	
Stroke	135 mm		5 in		135 mm		5 in		135 mm		5 in	

*Range 4 power and torque is equal to Performance Mode with Caterpillar Power by Range technology.

**The Cat C7.1 engine meets U.S. EPA Tier 4 Final/EU Stage IV off-highway emission standards.

***The Cat C7.1 engine meets U.S. EPA Tier 4 Final/EU Stage V off-highway emission standards.

- Net power ratings are tested at the reference conditions for the specified standard and denote power available at the flywheel when the engine is equipped with alternator, air cleaner, emission components and fan at specified speed.
- No derating required up to 3000 m (10,000 ft) altitude. Auto derate protects hydraulic and transmission systems.

Engine Torque

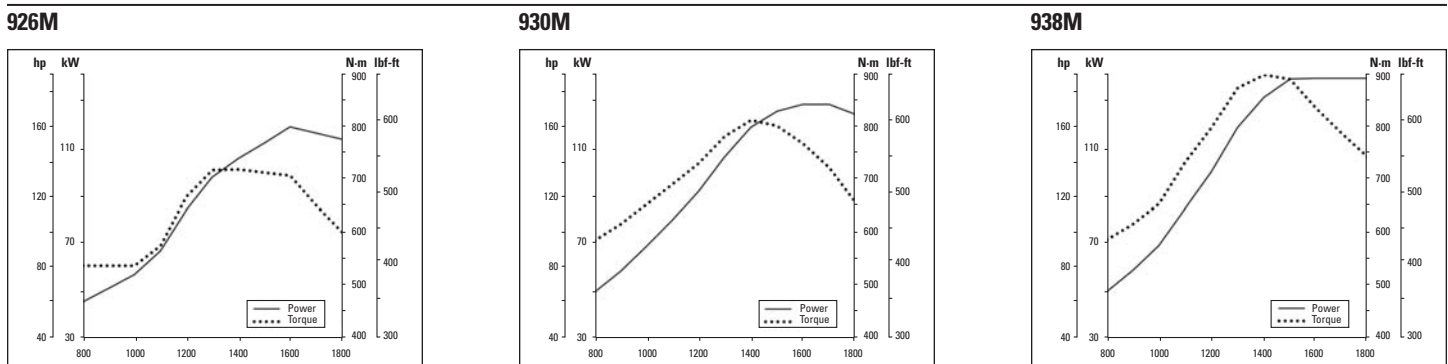

Cab



- ROPS: ISO 3471: 2008, FOPS: ISO 3449: 2005 LEVEL II
- Declared Sound Levels
 - Operator Sound Pressure Level (ISO 6396:2008): 68 dB(A)*
 - Exterior Sound Power Level (ISO 6395:2008): 101 dB(A)*

* Measurements were conducted at 70% of maximum engine cooling fan speed. Sound level may vary at different engine cooling fan speeds. The cab was properly installed and maintained. The measurements were conducted with the cab doors and the cab windows closed.

- The Blue Angel environmental label is an optional attachment for Europe only.

Small Wheel Loaders Aggregate Handler Specifications

Loader Hydraulic System



- Implement system uses a dedicated load sensing variable displacement pump with dual double acting lift cylinders and a single double acting tilt cylinder.
- Flow values listed are for a machine running in Performance Power Mode (1,800 rpm).

* 3rd and 4th function flow is fully adjustable from 20% to 100% of maximum flow through the secondary display when equipped.

	926M		930M		938M	
Maximum Flow – Implement Pump	150 L/min	40 gal/min	190 L/min	50 gal/min	190 L/min	50 gal/min
3rd Function Maximum Flow*	150 L/min	40 gal/min	190 L/min	50 gal/min	190 L/min	50 gal/min
4th Function Maximum Flow*	150 L/min	40 gal/min	160 L/min	42 gal/min	160 L/min	42 gal/min
Maximum Working Pressure – Implement Pump	26 000 kPa	3,771 psi	26 000 kPa	3,771 psi	28 000 kPa	4,061 psi
Relief Pressure – Tilt Cylinder	28 000 kPa	4,061 psi	28 000 kPa	4,061 psi	30 000 kPa	4,351 psi
3rd and 4th Function Maximum Working Pressure	26 000 kPa	3,771 psi	26 000 kPa	3,771 psi	28 000 kPa	4,061 psi
3rd and 4th Function Relief Pressure	28 000 kPa	4,061 psi	28 000 kPa	4,061 psi	30 000 kPa	4,351 psi
Lift Cylinder: Double Acting						
Bore Diameter	110 mm	4.3 in	120 mm	4.7 in	120 mm	4.7 in
Rod Diameter	60 mm	2.4 in	65 mm	2.6 in	65 mm	2.6 in
Stroke	728 mm	28.7 in	728 mm	28.7 in	789 mm	31.1 in
Tilt Cylinder: Double Acting						
Bore Diameter	130 mm	5.1 in	150 mm	5.9 in	150 mm	5.9 in
Rod Diameter	70 mm	2.8 in	90 mm	3.5 in	90 mm	3.5 in
Stroke	555 mm	21.9 in	555 mm	21.9 in	555 mm	21.9 in
Cycle Times: Performance (HP+) at 1,800 rpm/ Standard Power Mode at 1,600 rpm						
Raise (Ground Level to Maximum Lift)	5.5/6.2 seconds		5.1/5.7 seconds		5.5/6.2 seconds	
Dump (at Maximum Lift Height)	1.5/1.7 seconds		1.5/1.7 seconds		1.5/1.7 seconds	
Float Down (Maximum Lift to Ground Level)	2.6/2.6 seconds		2.7/2.7 seconds		2.7/2.7 seconds	
Total Cycle Time	9.6/10.5 seconds		9.3/10.1 seconds		9.7/10.6 seconds	

Steering



- Steering system uses a dedicated load sensing variable displacement pump with dual double acting cylinders.
- Flow values listed are for a machine running in Performance Power Mode (1,800 rpm).

	926M		930M		938M	
Steering Cylinder: Double Acting						
Bore Diameter	70 mm	2.8 in	70 mm	2.8 in	80 mm	3.1 in
Rod Diameter	40 mm	1.6 in	40 mm	1.6 in	50 mm	2 in
Stroke	438 mm	17.2 in	438 mm	17.2 in	399 mm	15.7 in
Maximum Flow – Steering Pump	130 L/min	34 gal/min	130 L/min	34 gal/min	130 L/min	34 gal/min
Maximum Working Pressure – Steering Pump	24 130 kPa	3,500 psi	24 130 kPa	3,500 psi	24 130 kPa	3,500 psi
Maximum Steering Torque						
0° (Straight Machine)	50 375 N·m	37,155 lbf-ft	50 375 N·m	37,155 lbf-ft	57 630 N·m	42,506 lbf-ft
40° (Full Turn)	37 620 N·m	27,747 lbf-ft	37 620 N·m	27,747 lbf-ft	42 570 N·m	31,398 lbf-ft
Steering Cycle Times (Full Left to Full Right)						
Minimum RPM: Pump Flow Limited	2.8 seconds		2.8 seconds		3.1 seconds	
Maximum RPM: 90 rpm Steering Wheel Speed	2.4 seconds		2.4 seconds		2.3 seconds	

Small Wheel Loaders Aggregate Handler Specifications

Transmission



* Creeper control allows maximum speed range adjustability from 1 km/h (0.6 mph) to 13 km/h (8 mph) in Range 1 through the secondary display when equipped. Factory default is 7 km/h (4.4 mph).

	926M		930M		938M	
Forward and Reverse						
Range 1*	1-13 km/h	0.6-8 mph	1-13 km/h	0.6-8 mph	1-13 km/h	0.6-8 mph
Range 2	13 km/h	8 mph	13 km/h	8 mph	13 km/h	8 mph
Range 3	27 km/h	17 mph	27 km/h	17 mph	27 km/h	17 mph
Range 4	40 km/h	25 mph	40 km/h	25 mph	40 km/h	25 mph

Service Refill Capacities

	926M		930M		938M	
Fuel Tank	195 L	51.5 gal	195 L	51.5 gal	195 L	51.5 gal
Diesel Exhaust Fluid (DEF) Tank	19 L	5.0 gal	19 L	5.0 gal	19 L	5.0 gal
Cooling System	30 L	7.9 gal	30 L	7.9 gal	32 L	8.5 gal
Engine Crankcase	20 L	5.3 gal	20 L	5.3 gal	20 L	5.3 gal
Transmission (Gear Box)	8.5 L	2.2 gal	8.5 L	2.2 gal	11 L	2.9 gal
Axles						
Front	21 L	5.5 gal	26 L	6.9 gal	35 L	9.2 gal
Rear	21 L	5.5 gal	25 L	6.6 gal	35 L	9.2 gal
Hydraulic System (Including Tank)	160 L	42.3 gal	165 L	43.6 gal	170 L	44.9 gal
Hydraulic Tank	90 L	23.8 gal	90 L	23.8 gal	90 L	23.8 gal

Power Train

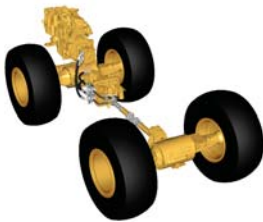

- Power train is governed by the Caterpillar exclusive Intelligent Power Management system to deliver peak performance and efficiency.
- Offset rims available to meet European roading requirements.

*Differential front locking axle can be engaged on the go at full torque to 10 km/h (6.2 mph) on the 926M/930M and up to 20 km/h (12.4 mph) on the 938M.

	926M	930M	938M
Front Axle	Fixed	Fixed	Fixed
Traction Aid*	Locking differential (standard)	Locking differential (standard)	Locking differential (standard)
Rear Axle	Oscillating	Oscillating	Oscillating
Oscillation Angle by Tire Size			
17.5 R25	± 13.5 degrees	—	—
20.5 R25, 550/65, 600/65, 650/65	± 10.5 degrees	± 10.5 degrees	± 10.5 degrees
23.5 R25	—	—	± 7 degrees
Traction Aid (optional)	Limited slip differential	Limited slip differential	Limited slip differential
Brakes			
Service	Inboard wet disc	Inboard wet disc	Outboard wet disc
Park	Spring applied hydraulically released	Spring applied hydraulically released	Spring applied hydraulically released

Small Wheel Loaders Aggregate Handler Specifications

Dimensions with Bucket

All dimensions are approximate. Dimensions will vary with bucket, and tire choice. Refer to Operating Specifications with Buckets.

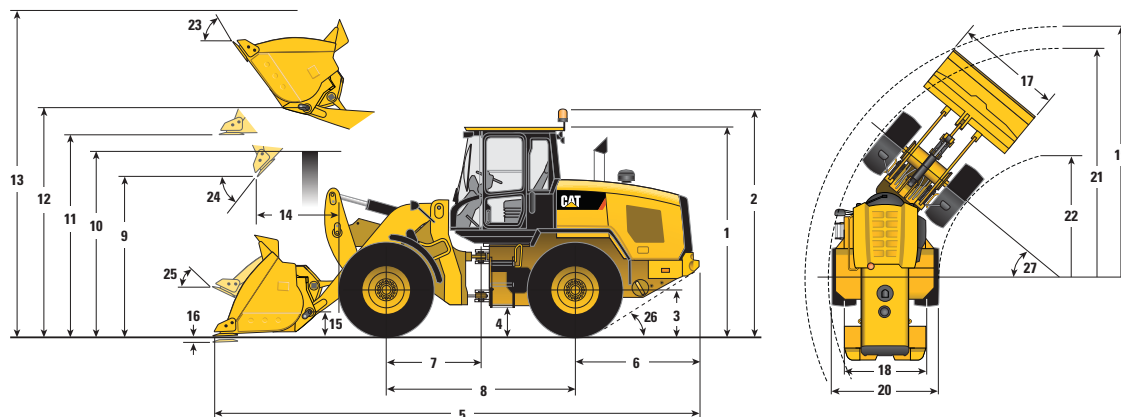

*Vary with bucket.

**Vary with tire.

Standard Lift

	926M		930M		938M	
** 1 Height: Ground to Cab	3340 mm	10'11"	3340 mm	10'11"	3340 mm	10'11"
** 2 Height: Ground to Beacon	3707 mm	12'2"	3707 mm	12'2"	3707 mm	12'2"
** 3 Height: Ground to Axle Center	685 mm	2'3"	685 mm	2'3"	685 mm	2'3"
** 4 Height: Ground Clearance	397 mm	1'4"	397 mm	1'4"	386 mm	1'3"
* 5 Length: Overall	7511 mm	24'8"	7613 mm	25'0"	7715 mm	25'4"
6 Length: Rear Axle to Bumper	1953 mm	6'5"	1993 mm	6'6"	1968 mm	6'5"
7 Length: Hitch to Front Axle	1500 mm	4'11"	1500 mm	4'11"	1525 mm	5'0"
8 Length: Wheel Base	3000 mm	9'10"	3000 mm	9'10"	3050 mm	10'0"
* 9 Clearance: Bucket at 45°	2807 mm	9'3"	2761 mm	9'1"	2786 mm	9'2"
** 10 Clearance: Load over Height	3330 mm	10'11"	3331 mm	10'11"	3354 mm	11'0"
** 11 Clearance: Level Bucket	3580 mm	11'9"	3580 mm	11'9"	3642 mm	11'11"
** 12 Height: Bucket Pin	3907 mm	12'10"	3907 mm	12'10"	3969 mm	13'0"
** 13 Height: Overall	5180 mm	17'0"	5239 mm	17'2"	5411 mm	17'9"
* 14 Reach: Bucket at 45°	1070 mm	3'6"	1109 mm	3'8"	1178 mm	3'10"
15 Carry Height: Bucket Pin	410 mm	1'4"	410 mm	1'4"	418 mm	1'4"
** 16 Dig Depth	100 mm	0'3.9"	100 mm	0'3.9"	100 mm	0'3.9"
17 Width: Bucket	2750 mm	9'0"	2750 mm	9'0"	2750 mm	9'0"
18 Width: Tread Center	1933 mm	6'4"	1930 mm	6'4"	2083 mm	6'10"
19 Turning Radius: Over Bucket	6034 mm	19'10"	6052 mm	19'10"	6142 mm	20'2"
20 Width: Over Tires	2543 mm	8'4"	2540 mm	8'4"	2693 mm	8'10"
21 Turning Radius: Outside of Tires	5404 mm	17'9"	5402 mm	17'9"	5546 mm	18'2"
22 Turning Radius: Inside of Tires	2850 mm	9'4"	2851 mm	9'4"	2843 mm	9'4"
23 Rack Angle at Full Lift	54°		54°		54°	
24 Dump Angle at Full Lift	48°		48°		48°	
25 Rack Angle at Carry	44°		44°		44°	
26 Departure Angle	33°		33°		33°	
27 Articulation Angle	40°		40°		40°	
Operating Weight	13 036 kg	28,739 lb	14 374 kg	31,689 lb	16 199 kg	35,712 lb

Bucket Specifications

Operating Specifications with Buckets

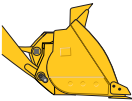
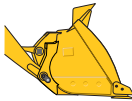
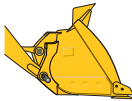
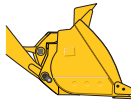
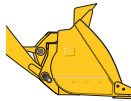
Aggregate Handler		Pin On				
		 926M	 930M	 930M	 938M	 938M
Capacity – Rated	m ³	2.5	2.5	2.7	2.9	3.2
	yd ³	3.3	3.3	3.5	3.8	4.2
Capacity – Rated at 110% Fill Factor	m ³	2.8	2.8	3.0	3.2	3.5
	yd ³	3.6	3.6	3.9	4.2	4.6
17 Width: Bucket	mm	2750	2750	2750	2750	2750
	ft/in	9'0"	9'0"	9'0"	9'0"	9'0"
Nominal Material Density, 110% Fill Factor	kg/m ³	1412	1677	1549	1655	1499
	lb/yd ³	2,379	2,826	2,611	2,790	2,526
9 Clearance: Full Lift, 45° Dump	mm	2807	2807	2761	2822	2786
	ft/in	9'3"	9'3"	9'1"	9'3"	9'2"
14 Reach: Full Lift, 45° Dump	mm	1070	1070	1109	1146	1178
	ft/in	3'6"	3'6"	3'8"	3'9"	3'10"
Reach: 2130 mm (7'0") Clearance, 45° Dump	mm	1573	1573	1587	1652	1664
	ft/in	5'2"	5'2"	5'2"	5'5"	5'6"
Reach: Level Arm, Level Bucket	mm	2413	2413	2475	2514	2563
	ft/in	7'11"	7'11"	8'1"	8'3"	8'5"
16 Dig Depth	mm	100	100	100	100	100
	in	3.9"	3.9"	3.9"	3.9"	3.9"
5 Length: Overall	mm	7511	7551	7613	7666	7715
	ft/in	24'8"	24'9"	25'0"	25'2"	25'4"
13 Height: Overall	mm	5180	5180	5239	5301	5411
	ft/in	17'0"	17'0"	17'2"	17'5"	17'9"
19 Turning Radius Bucket at Carry	mm	6034	6034	6052	6127	6142
	ft/in	19'10"	19'10"	19'10"	20'1"	20'2"
Tipping Load – Straight, ISO 14397-1*	kg	9182	10 959	10 817	12 427	12 418
	lb	20,242	24,160	23,847	27,396	27,376
Tipping Load – Straight, Rigid Tire**	kg	9564	11 416	11 268	12 945	12 935
	lb	21,085	25,167	24,841	28,537	28,516
Tipping Load – Full Turn, ISO 14397-1*	kg	7860	9337	9203	10 561	10 551
	lb	17,328	20,583	20,289	23,282	23,260
Tipping Load – Full Turn, Rigid Tire**	kg	8362	9932	9791	11 235	11 224
	lb	18,435	21,897	21,584	24,768	24,744
Breakout force	kg	9331	12 610	11 915	13 030	12 523
	lb	20,571	27,800	26,266	28,726	27,608
Operating Weight	kg	13 036	14 284	14 374	16 170	16 199
	lb	28,739	31,489	31,689	35,647	35,712

*Full compliance to ISO 14397-1:2007 Sections 1 thru 6, which requires 2% verification between calculation and testing.

**Compliance to ISO 14397-1:2007 Sections 1 thru 5.

Note: Dimensions listed are for machines configured with sand and gravel buckets, bolt-on cutting edges, maximum counterweight, 80 kg (176 lb) operator, and Michelin 20.5 R25 (L-3) XHA2 tires at a pressure of 4.14 bar (60 psi) in the front tires and 2.76 bar (40 psi) in the rear tires.

Operating Specifications with Buckets

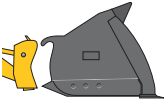
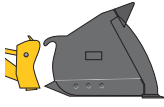
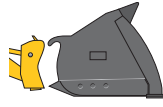
Aggregate Handler		Fusion				
		 926M	 930M		 938M	
Capacity – Rated	m ³	2.5	2.5	2.7	2.9	3.2
	yd ³	3.3	3.3	3.5	3.8	4.2
Capacity – Rated at 110% Fill Factor	m ³	2.8	2.8	3.0	3.2	3.5
	yd ³	3.6	3.6	3.9	4.2	4.6
17 Width: Bucket	mm	2747	2747	2747	1373.5	2747
	ft/in	9'0"	9'0"	9'0"	4'6"	9'0"
Nominal Material Density, 110% Fill Factor	kg/m ³	1323	1587	1460	1571	1407
	lb/yd ³	2,231	2,675	2,461	2,649	2,372
9 Clearance: Full Lift, 45° Dump	mm	2779	2779	2733	2751	2752
	ft/in	9'1"	9'1"	9'0"	9'0"	9'0"
14 Reach: Full Lift, 45° Dump	mm	1102	1102	1140	1216	1215
	ft/in	3'7"	3'7"	3'9"	4'0"	4'0"
Reach: 2130 mm (7'0") Clearance, 45° Dump	mm	1590	1590	1603	1684	1684
	ft/in	5'3"	5'3"	5'3"	5'6"	5'6"
Reach: Level Arm, Level Bucket	mm	2455	2455	2517	2615	2614
	ft/in	8'1"	8'1"	8'3"	8'7"	8'7"
16 Dig Depth	mm	100	100	100	101	100
	in	3.9"	3.9"	3.9"	4.0"	3.9"
5 Length: Overall	mm	7553	7593	7655	7767	7766
	ft/in	24'9"	24'11"	25'1"	25'6"	25'6"
13 Height: Overall	mm	5205	5205	5264	5379	5441
	ft/in	17'1"	17'1"	17'3"	17'8"	17'10"
19 Turning Radius Bucket at Carry	mm	6042	6042	6060	5540	6153
	ft/in	19'10"	19'10"	19'11"	18'2"	20'2"
Tipping Load – Straight, ISO 14397-1*	kg	8568	10 316	10 258	11 844	11 734
	lb	18,889	22,742	22,614	26,111	25,867
Tipping Load – Straight, Rigid Tire**	kg	8925	10 746	10 685	12 338	12 223
	lb	19,676	23,689	23,556	27,199	26,945
Tipping Load – Full Turn, ISO 14397-1*	kg	7279	8730	8673	10 025	9906
	lb	16,046	19,246	19,121	22,101	21,838
Tipping Load – Full Turn, Rigid Tire**	kg	7743	9287	9227	10 665	10 538
	lb	17,070	20,474	20,341	23,512	23,232
Breakout force	kg	8815	11 982	11 353	11 990	11 847
	lb	19,433	26,416	25,028	26,432	26,116
Operating Weight	kg	13 535	14 783	14 831	16 567	16 734
	lb	29,840	32,589	32,696	36,522	36,891

*Full compliance to ISO 14397-1:2007 Sections 1 thru 6, which requires 2% verification between calculation and testing.

**Compliance to ISO 14397-1:2007 Sections 1 thru 5.

Note: Dimensions listed are for machines configured with sand and gravel buckets, bolt-on cutting edges, maximum counterweight, 80 kg (176 lb) operator, and Michelin 20.5 R25 (L-3) XHA2 tires at a pressure of 4.14 bar (60 psi) in the front tires and 2.76 bar (40 psi) in the rear tires.

Bucket Selection Tables

Sand and Gravel Bucket Selection – Standard Lift

Material Type		Fill Factor %														Tip Load Full Turn*	
		105%	105%	110%	105%	115%	105%	105%	105%	105%	110%	110%	110%	110%	110%		
926M	Pin On	m ³ yd ³	Counter-weight	kg/m ³ lb/yd ³	1300 (2,191)	1375 (2,318)	1450 (2,444)	1525 (2,570)	1600 (2,697)	1675 (2,823)	1750 (2,950)	1825 (3,076)	1900 (3,202)	1975 (3,329)	2050 (3,455)	kg	lb
				2.5 (3.3)	Aggregate		115%	110%	105%	100%							
	Fusion	2.5 (3.3)	Aggregate	110%	105%	100%										7279	(16,046)
930M	Pin On	m ³ yd ³	Counter-weight	kg/m ³ lb/yd ³	1300 (2,191)	1375 (2,318)	1450 (2,444)	1525 (2,570)	1600 (2,697)	1675 (2,823)	1750 (2,950)	1825 (3,076)	1900 (3,202)	1975 (3,329)	2050 (3,455)	kg	lb
				2.5 (3.3)	Aggregate				115%	110%	105%	100%					9337
		2.7 (3.5)	Aggregate			115%	110%	105%	100%							9203	(20,289)
	Fusion	2.5 (3.3)	Aggregate			115%	110%	105%	100%							8730	(19,246)
		2.7 (3.5)	Aggregate	115%	110%	105%	100%									8673	(19,121)
938M	Pin On	m ³ yd ³	Counter-weight	kg/m ³ lb/yd ³	1300 (2,191)	1375 (2,318)	1450 (2,444)	1525 (2,570)	1600 (2,697)	1675 (2,823)	1750 (2,950)	1825 (3,076)	1900 (3,202)	1975 (3,329)	2050 (3,455)	kg	lb
				2.9 (3.8)	Aggregate				115%	110%	105%	100%					10 561
		3.2 (4.2)	Aggregate		115%	110%	105%	100%								10 551	(23,260)
	Fusion	2.9 (3.8)	Aggregate			115%	110%	105%	100%							10 025	(22,101)
		3.2 (4.2)	Aggregate	115%	110%	105%	100%									9906	(21,838)

Material density, fill factor, and counterweight options are key variables when choosing the appropriate bucket size. The long floor and open throat design of the Performance Series Buckets along with the aggressive rack angles of the optimized linkage will demonstrate fill factors greater than the 100% ISO rating as per the serial number plate on the work tool. Refer to the expected fill factor % per material type at the top of the table and find a matching counterweight and fill factor along the side for proper bucket sizing.

*Full compliance to ISO 14397-1:2007 Section 1 thru 6, which requires 2% verification between calculation and testing.

Operating Specifications with Forks

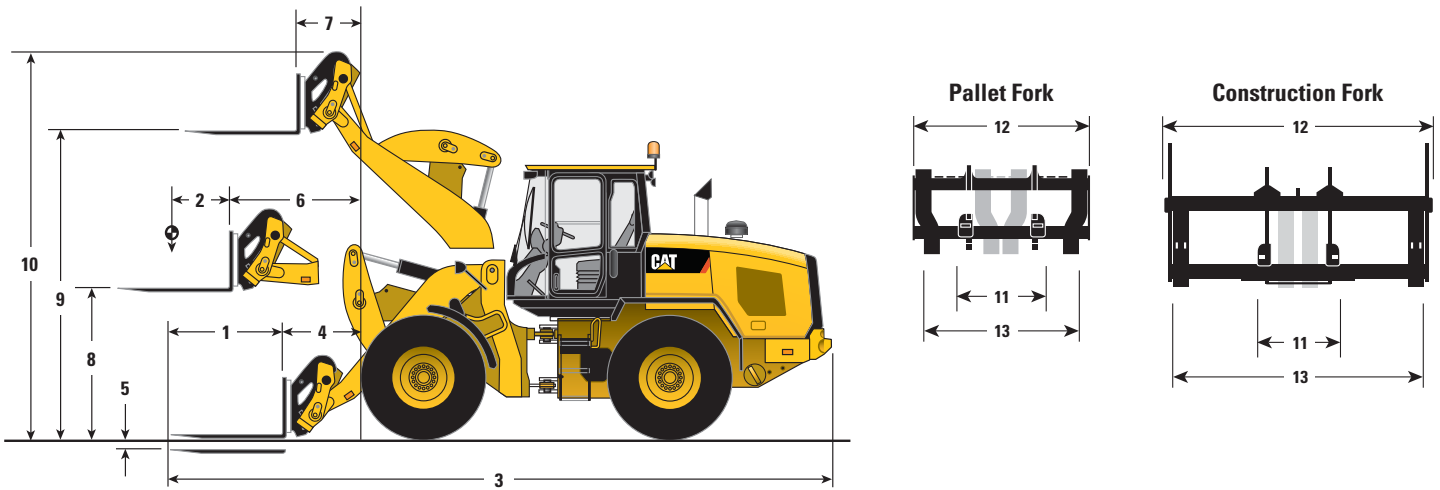

	Pallet Fork – Fusion						Construction Fork – Fusion					
	926M		930M		938M		926M		930M		938M	
	mm	ft/in	mm	ft/in	mm	ft/in	mm	ft/in	mm	ft/in	mm	ft/in
1 Fork tine length	1220	4'0"	1220	4'0"	1220	4'0"	1524	5'0"	1524	5'0"	1524	5'0"
2 Load center	610	2'0"	610	2'0"	610	2'0"	762	2'6"	762	2'6"	762	2'6"
3 Length: overall	7842	25'9"	7882	25'10"	7942	26'1"	8271	27'2"	8311	27'3"	8372	27'6"
4 Reach: ground	926	3'0"	926	3'0"	961	3'2"	1050	3'5"	1050	3'5"	1086	3'7"
5 Dig depth	47	1.9"	47	1.9"	44	1.7"	126	5.0"	126	5.0"	125	4.9"
6 Reach: arm level	1569	5'2"	1569	5'2"	1617	5'4"	1628	5'4"	1628	5'4"	1676	5'6"
7 Reach: full lift	767	2'6"	767	2'6"	814	2'8"	826	2'9"	826	2'9"	873	2'10"
8 Clearance: level arm	1792	5'11"	1792	5'11"	1830	6'0"	1724	5'8"	1724	5'8"	1760	5'9"
9 Clearance: full lift	3693	12'1"	3693	12'1"	3758	12'4"	3625	11'11"	3625	11'11"	3688	12'1"
10 Height: overall	4676	15'4"	4676	15'4"	4740	15'7"	4935	16'2"	4935	16'2"	4999	16'5"
11 Minimum fork spacing	300	1'0"	300	1'0"	300	1'0"	300	1'0"	300	1'0"	300	1'0"
12 Carriage width	1566	5'2"	1566	5'2"	1566	5'2"	2498	8'2"	2498	8'2"	2498	8'2"
13 Maximum fork spacing	1550	5'1"	1550	5'1"	1550	5'1"	2375	7'10"	2375	7'10"	2375	7'10"
	kg	lb	kg	lb	kg	lb	kg	lb	kg	lb	kg	lb
Tipping load – straight, ISO 14397-1*	6998	15,428	8324	18,352	9530	21,010	6246	13,770	7482	16,495	8614	18,990
Tipping load – full turn, ISO 14397-1*	6008	13,246	7109	15,673	8124	17,909	5328	11,747	6355	14,010	7307	16,108
Operating weight	12852	28,333	14100	31,083	15935	35,128	13229	29,165	14477	31,915	16312	35,960
Rated load % of full turn tip:												
50% of tip: SAE J1197**	3004	6,623	3555	7,837	4062	8,954	2664	5,873	3178	7,005	3653	8,054
60% of tip: rough terrain EN474-3**	3605	7,948	4266	9,404	4874	10,745	3197	7,048	3813	8,406	4384	9,665
80% of tip: firm and level EN474-3**	4807	10,597	5688	12,539	6499	14,327	4263	9,397	5084	11,208	5845	12,886

*Full compliance to ISO 14397-1:2007 Sections 1 thru 6, which requires 2% verification between calculation and testing.

**Compliance to EN474-3 and SAE J1197.

Note: Dimensions listed are for a machine configured with Fusion work tools, maximum counterweight, 80 kg (176 lb) operator, and Michelin 20.5 R25 (L-3) XHA2 tires.

Supplemental Specifications

Optional Equipment

	926M				930M				938M			
	Operating Weight		Tipping Load – Full Turn with 2.5 m ³ (3.3 yd ³) Pin On Bucket		Operating Weight		Tipping Load – Full Turn with 2.7 m ³ (3.5 yd ³) Pin On Bucket		Operating Weight		Tipping Load – Full Turn with 2.9 m ³ (3.8 yd ³) Pin On Bucket	
	kg	lb	kg	lb	kg	lb	kg	lb	kg	lb	kg	lb
Change with Options Removed:												
Heavy Counterweight	N/A	N/A	N/A	N/A	-320	-705	-504	-1,111	-320	-705	-499	-1,099
Aggregate Counterweight	-298	-658	-421	-929	-298	-658	-410	-903	-298*	-658*	-406*	-894*
Guard, Power Train Lower	-77	-170	-70	-154	-77	-170	-70	-153	-70	-155	-63	-138
Guard, Driveshaft	-44	-97	-12	-26	-44	-97	-12	-26	-45	-100	-12	-27
Guard, Crankcase	-11	-24	-14	-32	-11	-24	-14	-32	-11	-24	-14	-31
Ride Control	-49	-108	-26	-58	-49	-108	-26	-58	-49	-108	-27	-59
Guard, Power Train Side	-10	-21	-8	-18	-10	-21	-8	-18	-10	-21	-8	-18
Change with Options Added:												
Secondary Steer	+69	+152	+74	+162	+69	+152	+73	+162	+69	+152	+73	+162
Roading Fenders	+18	+39	+24	+53	+18	+39	+24	+52	+18	+39	+24	+52
Cold Start Package	+54	+119	+75	+165	+54	+119	+75	+164	+54	+119	+74	+164

*Aggregate counterweight not compatible with 23.5 tires on 938M.

Tire Options



	926M				930M				938M*			
	550/65R25 (L-3)		17.5R25 (L-3)		600/65R25 (L-3)		20.5R25 (L-5)		23.5R25**		650/65 R25	
Change with Tire Option as Compared to 20.5R25 (L-3) Tire	mm	in	mm	in	mm	in	mm	in	mm	in	mm	in
Vertical Heights	-70	-2.8"	-65	-2.6"	-15	-0.6"	+35	+1.4"	+65	+2.6"	-35	-1.4"
Reach: Bucket at 45°	+44	+1.7"	+74	+2.9"	+29	+1.1"	-22	-0.8"	-63	-2.5"	-5	-0.2"
Width: Over Tires	+21	+0.8"	-69	-2.7"	+101	+4.0"	-14	-0.6"	+38	+1.5"	+61	+2.4"
Turning Radius: Outside of Tires	+4	+0.2"	-45	-1.8"	+44	+1.7"	+26	+1.0"	+20	+0.8"	+23	+0.9"
Turning Radius: Inside of Tires	-11	-0.4"	+35	+1.4"	-51	-2.0"	+7	+0.3"	-19	-0.7"	-31	-1.2"
	kg	lb	kg	lb	kg	lb	kg	lb	kg	lb	kg	lb
Tipping Load – Straight	-83	-183	-212	-468	+9	+21	+398	+877	+484	+1,067	+365	+805
Tipping Load – Full Turn	-72	-158	-184	-405	+8	+18	+344	+758	+418	+923	+316	+696
Operating Weight	-126	-277	-322	-709	+14	+31	+605	+1,335	+738	+1,626	+557	+1,227

*Offset rims available to meet European roading requirements.

**938M compatible with standard counterweight for general construction and heavy counterweight for Aggregate or Forest Handlers.

Ground Engagement Options



Bolt-on Cutting Edge

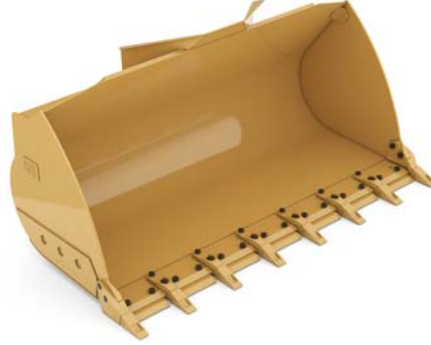

Long Teeth and Segments

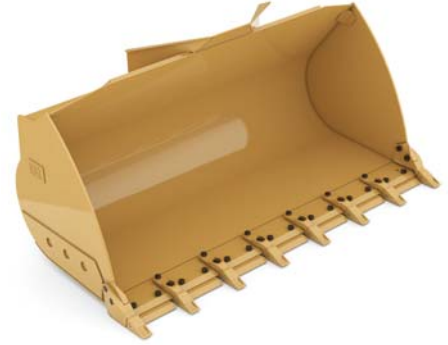

Short Teeth and Segments

Change with Ground Engagement Option Compared to Bolt-on Cutting Edge	926M				930M				938M			
	Long Teeth and Segments		Short Teeth and Segments		Long Teeth and Segments		Short Teeth and Segments		Long Teeth and Segments		Short Teeth and Segments	
	mm	in	mm	in	mm	in	mm	in	mm	in	mm	in
Dig Depth	+12	+0.5"	+5	+0.2"	+11	+0.5"	+5	+0.2"	+12	+0.5"	+5	+0.2"
Length: Overall	+146	+5.7"	+121	+4.8"	+146	+5.7"	+121	+4.8"	+146	+5.7"	+121	+4.8"
Dump Clearance	-105	-4.1"	-84	-3.3"	-106	-4.2"	-85	-3.3"	-107	-4.2"	-85	-3.3"
Reach	+102	+4.0"	+87	+3.4"	+101	+4.0"	+86	+3.4"	+101	+4.0"	+86	+3.4"
	kg	lb	kg	lb	kg	lb	kg	lb	kg	lb	kg	lb
Tipping Load – Straight	-151	-333	-145	-319	-140	-310	-134	-296	-141	-311	-135	-297
Tipping Load – Full Turn	-148	-326	-142	-312	-137	-303	-131	-290	-138	-304	-132	-291
Breakout Force	-121	-266	-115	-254	-112	-246	-106	-234	-112	-246	-106	-234
Operating Weight	+120	+265	+116	+255	+111	+245	+106	+234	+111	+245	+106	+234

Small Wheel Loaders Aggregate Handler Standard Equipment

Standard Equipment

Standard equipment may vary. Consult your Cat dealer for details.

POWER TRAIN

- Axle seal guards
- Auto idle shut down feature
- Cat C7.1 engine
 - Power Modes (Standard and Performance)
 - Power by Range (High Power in Range 4)
 - Turbocharged and aftercooled
 - Filtered crankcase breather
 - Diesel particulate filter (Fit for Life)
- Coolant protection to -34°C (-29°F)
- Differential lock in front axle
- Dry type air cleaner
- Enclosed wet disc full hydraulic brakes
- Fuel priming pump, automatic
- Fuel water separator
- Hydraulically driven demand cooling fan
- Intelligent hydrostatic transmission
 - Power train modes
 - Directional Shift Aggressiveness
 - Rimpull control, adjust wheel torque
 - Creeper control, adjust ground speed
- Lubed for life driveshafts
- Parking brake, electric
- Wide spaced 6 fins per inch cooling package
- S·O·SSM sampling ports
- Throttle lock and maximum speed limiter

HYDRAULICS

- Automatic lift, lower and tilt kickouts
- Bucket and Fork Modes, adjustable in-cab
- Cylinder damping at kickout and end stops
- Fine Mode control in Fork Mode
- Hydraulic Response setting
- Load sensing hydraulics and steering
- Seat-mounted hydraulic joystick controls

ELECTRICAL

- Alternator, 115-amp, heavy duty
- 12V power supply in cab (2)
- Batteries, 1,000 CCA (2) 24 volt system
- Back-up alarm
- Emergency shutdown switch
- Heavy duty gear reduction starter
- Product Link PRO with subscription
- Remote jump start post
- Resettable main and critical function breakers

OPERATOR ENVIRONMENT

- 75 mm (3 in) retractable seat belt, with audible alarm and indicator
- Automatic temperature control
- Cab, enclosed and pressurized
- Cup holders
- External heated mirrors with lower parabolic
- Ground level cab door release

Gauges

- Digital hour meter, odometer, tachometer, ground speed and direction indicator
- Engine coolant temperature gauge
- Fuel and Diesel Exhaust Fluid level
- Hydraulic oil temperature gauge
- Hydraulic control lockout
- Interior cab lighting, door and dome
- Interior rearview mirrors (2)
- Lunch box storage
- Operator warning system indicators
- Radio ready speakers
- Rear window defrost, electric
- Seat-mounted controls, adjustable
- Sliding glass on the side windows
- Column mounted multi function control – lights, wipers, turn signal
- Suspension seat, fabric
- Tilt and telescopic steering wheel
- Wet arm wiper/washer, front and rear

OTHER STANDARD EQUIPMENT

- Large-access enclosure doors
- Parallel lift loader linkage
- Recovery hitch with pin
- Remote mounted lubrication points
- Lockable compartments and enclosures

Small Wheel Loaders Aggregate Handler Optional Equipment

Optional Equipment

Optional equipment may vary. Consult your Cat dealer for details.

- Antifreeze/coolant, extended-life
- Autolube, integrated in secondary display
- Auxiliary flow, third function
- Axles, differential, limited slip, rear
- Axles, elevated breathers
- Beacon light, strobe
- Cab, deluxe (standard in Europe):
 - Automatic blower control
 - Electrically adjustable heated mirrors (2)
 - LED interior lighting
 - Secondary display to adjust settings
- Ride control adjustable speed activation
- Preventative maintenance reminders
- Integrated help function (22 languages available)
- Sunscreen, front and rear
- Camera, rearview (standard in Europe)
- Camera, front view*
- Cold start package:
 - Ether starting aid, block heater and additional batteries 1,000 CCA (4 in total)
- Coupler, (Fusion and ISO 23727)
- Debris packages (low, medium, high)
- Fenders (extended cover and full coverage)
- Guards
 - Power train, (lower, side, driveshaft and crankcase)
 - Windshield and lights
 - Cylinders, tilt and steering
- Lights, auxiliary, halogen or LED with engine and DEF compartment lights
- Lights, roading LED
- Rear Object Detection
- Radio packages:
 - Radio ready with Bluetooth
 - Radio, AM/FM with Bluetooth and clock
 - Radio, AM/FM with CD player deluxe, weatherband, Bluetooth and clock
- Seats:
 - Deluxe seat – fully adjustable fabric air suspension seat with high seat backrest
 - Premium seat – fully adjustable leather and fabric air suspension with high backrest and air lumbar support. Heated and cooled bottom cushion and backrest.
- Steering:
 - Dual mode and Secondary
- Tires:
 - Bias ply, 17.5, 20.5-25
 - Radial, 17.5, 20.5, 23.5, 550/65, 600/65, 650/65 R25
- Work tools

*May be required for local EU requirements.

For more complete information on Cat products, dealer services, and industry solutions, visit us on the web at www.cat.com

© 2019 Caterpillar
All rights reserved

Materials and specifications are subject to change without notice. Featured machines in photos may include additional equipment. See your Cat dealer for available options.

CAT, CATERPILLAR, LET'S DO THE WORK, their respective logos, "Caterpillar Yellow," the "Power Edge" and Cat "Modern Hex" trade dress as well as corporate and product identity used herein, are trademarks of Caterpillar and may not be used without permission.

VisionLink is a trademark of Trimble Navigation Limited, registered in the United States and in other countries.

AEHQ7796-01 (11-2019)
Replaces AEHQ7796
(Americas North,
Europe, Australia)

