

THE OFFSHORE PROJECT SHOWCASE

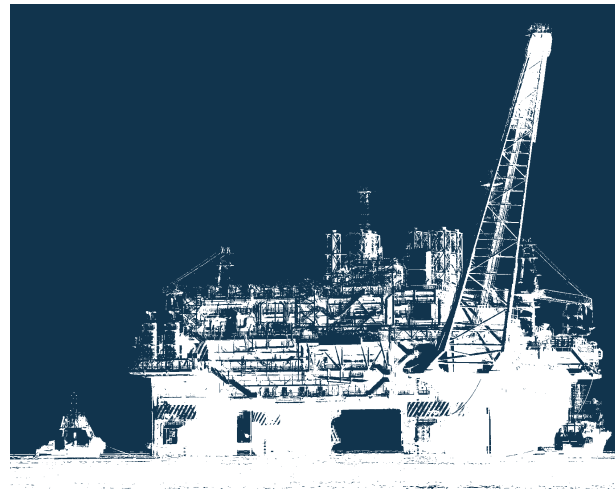

Extraordinary Infrastructure of the *Be Inspired* Awards

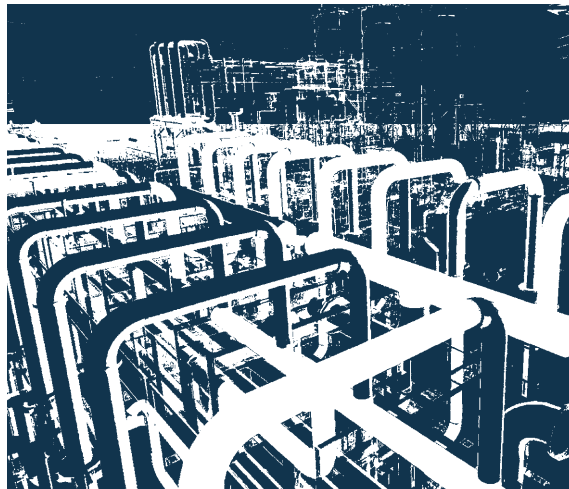

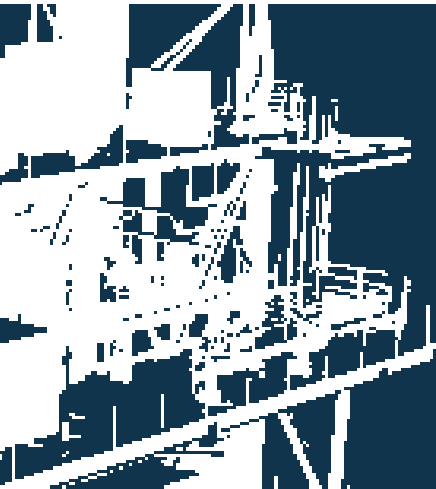
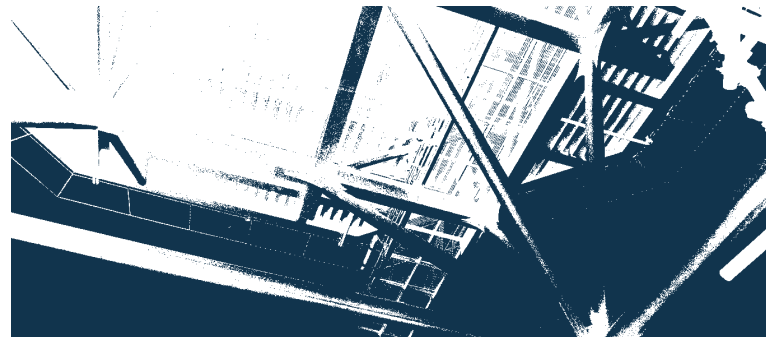
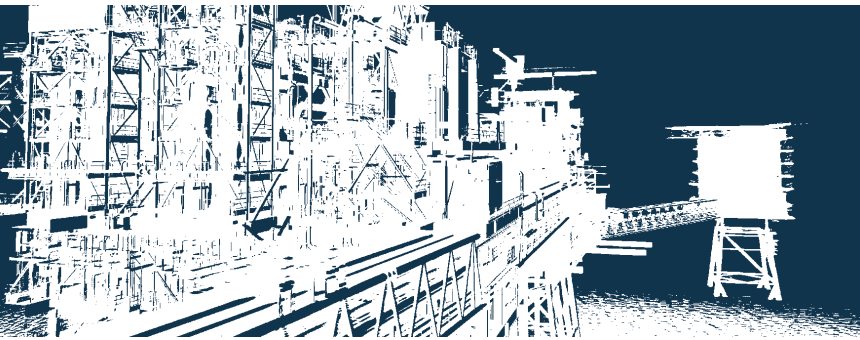
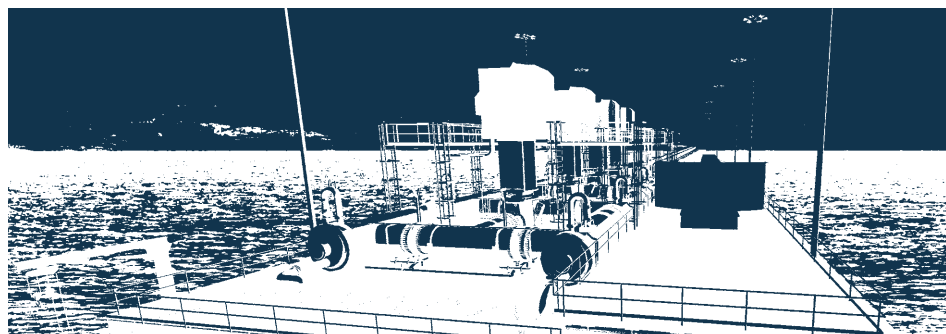
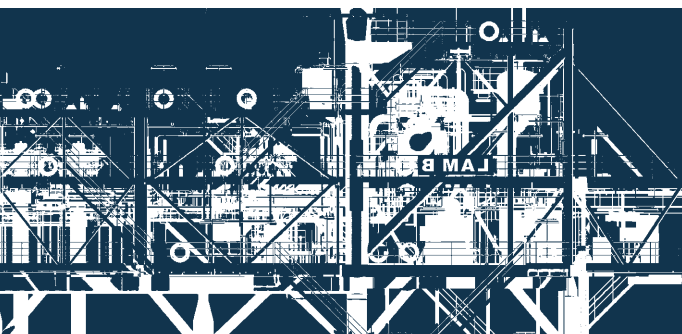

Bentley's mission is to provide innovative software and services for the enterprises and professionals who design, build, and operate the world's infrastructure – sustaining the global economy and environment for improved quality of life.

The Offshore Project Showcase and *The Year in Infrastructure* series of publications are project yearbooks published by Bentley Systems, Incorporated that showcase the extraordinary work of Bentley users sustaining the world's infrastructure.

For information about how to enter your innovative project for consideration in the next *Be Inspired Awards* competition or for additional information about this program, visit www.bentley.com/beinspired.

ONLINE VERSIONS

Digital versions of *Be Inspired Awards* publications are available online at www.bentley.com/yearininfrastructure. Choose to view a specific issue or search within each issue using terms, titles, or keywords.

Also browse Bentley's *Be Inspired* Project Portfolios at www.bentley.com/projects, which feature the winners and finalists in Bentley's annual *Be Inspired Awards* competition. Through these multimedia portfolios of exemplary project achievements, Bentley shares innovative best practices with the architects, engineers, constructors, geospatial professionals, and owner-operators who sustain the world's infrastructure.



Published by Bentley Systems, Incorporated
685 Stockton Drive
Exton, PA 19341
www.bentley.com

INNOVATIVE TECHNOLOGY ACROSS THE LIFECYCLE OF OFFSHORE PROJECTS

The professionals who design, build, and operate the infrastructure that sustains our world and improves the quality of life for the people who live in it are what drives the amazing projects presented in *The Offshore Project Showcase*.

These projects represent tremendous innovation in the use of Bentley software to produce intelligent infrastructure that is measured in terms of operational efficiency, constructability, safety, and use of energy and nonrenewable resources in offshore and marine environments. The state-of-the-art projects in *The Offshore Project Showcase* employ Bentley solutions to create new and sustainable value in every stage of the offshore project's lifecycle.

Among the Bentley software products featured in this showcase is SACS, an offshore engineering technology mainstay for nearly 40 years. SACS provides comprehensive analysis and design for the entire lifecycle of new and existing, fixed and floating offshore structures. Typically used in the oil, gas, and wind energy industries, SACS is also used in other industries such as transportation. Its ability to dynamically iterate designs allows users to perform advanced analysis, comply with offshore design criteria, and visualize complex results.

Bentley software tools that have been crucial to the development of offshore projects around the globe included in this showcase are:

- Offshore engineering and marine projects analysis and design (SACS)
- Plant design and engineering (OpenPlant, AutoPLANT, and PlantSpace)
- Structural analysis and design (STAAD.Pro, ProSteel, AutoPIPE, and ISM)
- Laser scanning and point-cloud data management (Bentley Pointools and ProjectWise Point-cloud Services)
- Geotechnical data management and reporting (gINT)
- Engineering collaboration (ProjectWise and Bentley Navigator)
- Construction planning and management (ConstructSim)
- Asset integrity management (AssetWise and AssetWise Ivara Performance Management)

Each project in *The Offshore Project Showcase* has been nominated for a *Be Inspired Award* for innovation in infrastructure. All demonstrate our society's resilience in the face of tremendous challenges and serve as a testament to the ability of engineers and architects, contractors, and owner-operators around the globe to solve any problem, great or small.

TABLE OF CONTENTS

OFFSHORE ENGINEERING	3 – 5
OIL AND GAS	7 – 27
VESSEL	29 – 31
WIND	33 – 36
INDEX	
ALPHABETICAL BY ORGANIZATION	37 – 38

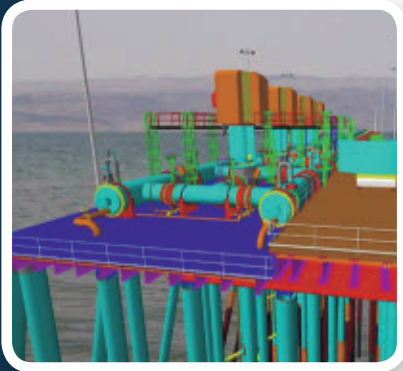

Offshore Engineering

Professionals can be challenged to provide solutions for unusual and complex problems arising in the offshore environment. The projects in this category represent amazing innovation in offshore engineering.

OFFSHORE ENGINEERING

Dar Al-Handasah

New Main Brine Intake Station at Dead Sea

Safi, Jordan

The Arab Potash Company produces potash by processing carnallite crystals extracted from Dead Sea brine. Due to receding sea levels, a new intake pumping station was required for operations at Safi, Jordan. Challenges included selecting materials to withstand the corrosive brine, designing for a location with poor geotechnical conditions, reducing power demands of hydraulic pumps, and testing a possible 400 structural load combinations.

Dar Al-Handasah met these design challenges with the help of MicroStation and PlantSpace, which allowed the team to coordinate design by incorporating all disciplines – mechanical, structural, geotechnical, and electrical – into a single model. The model was then used to extract drawings, plans, sections, and details for the contractor. These savings in design time led to cost savings for the USD 180 million station.

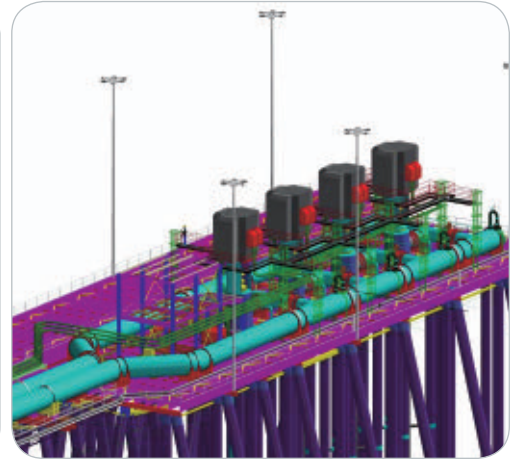
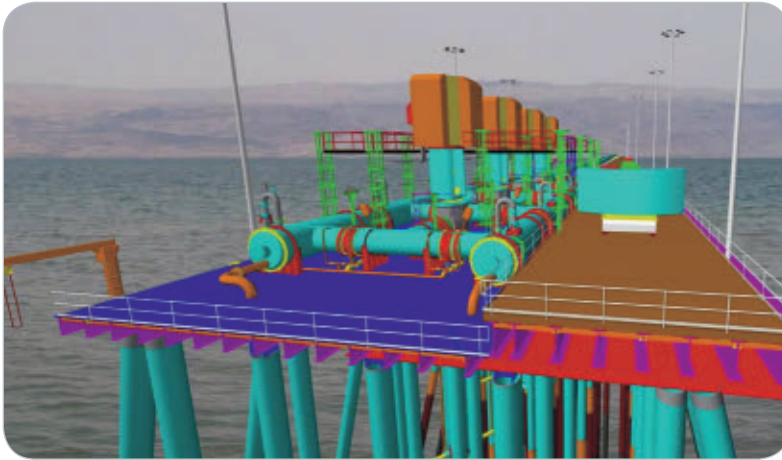

Nippon Steel & Sunikin Engineering Co., Ltd.

Tokyo International Airport Re-expansion Project

Tokyo, Japan

WINNER

The new JPY 600 billion D-runway at Tokyo International Airport is needed to accommodate growing demand and provide additional arrival and departure slots. With limited space, the only option is to build into the sea on an island 3,120 meters long with a 1,100-meter-long steel jacket-type pier. The first to be used in construction of airport infrastructure, the jacket structure is 520 meters wide, has an area of 520,000 square meters, and comprises 198 separate units.

Nippon Steel & Sumikin Engineering performed detailed design and led the five-year construction phase. SACS was used to conduct the complex fatigue analyses for the jacket units – totaling nearly 40,000 checkpoints – in just six months. Automatic calculation of stress concentration factors shortened the time required, and material take-offs allowed quantity estimates to be made immediately upon completion.



2012 WINNER

FINALIST

Robert Elks & Associates
Rock Bolting Rig
 Onslow, Australia

The USD 37 billion Gorgon project is developing the Gorgon and Jansz gas fields off the northwest coast of Western Australia. Part of this project is the 59.4-kilometer-long subsea DomGas pipeline. Robert Elks & Associates was retained to perform structural and mechanical engineering design and fabrication detailing for the rock bolting rig, which will install 1,546 pairs of stabilization anchors on the seabed along the pipeline.

The firm completed the project within 12 weeks. SACS calculated the environmental load for hundreds of combinations and checked members against standards. STAAD.Pro developed analysis models of welded assemblies, and data exchange with the latest ProStructures model integrated the workflows. The 3D environment allowed collaboration, visualization, and clash detection for a fully coordinated design.



2012 FINALIST

WINNER

TECON S.r.l.
Costa Concordia Wreck Removal Project
 Isola del Giglio, Grosseto, Italy



As the first salvage operation to raise a ship of this size without dismantling it, the USD 400 million Costa Concordia Wreck Removal Project challenge was to remove the Costa Concordia cruise ship off the shore of Isola del Giglio, Italy, while preserving the environment and restoring the site back to its original state. TECON designed the six underwater platforms for joint venture Titan (USA)-Micoperi (Italy).

interactions, wave forces, and load combinations. Using SACS saved TECON time and money by enabling them to respond to continuous changes and verify new results. SACS' user-friendly 3D output facilitated clear communication among the multi-discipline, international team. Thanks in part to this innovative solution, the wreck was righted and removed intact from this environmentally sensitive reef.

TECON created a flat plane over which the wreck could stand vertically, using SACS for all structural analysis: in-service, transportation, in-air and in-water lifting, pile/soil



SPECIAL RECOGNITION AWARD WINNER – INFRASTRUCTURE HERO OF THE YEAR

2013 WINNER



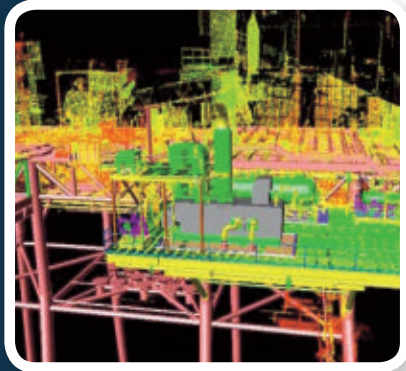

Oil and Gas

The offshore industry is driven by the need to increase production of hydrocarbons, both oil and natural gas. The projects in this category represent how technology has been utilized to meet the requirements for operational efficiency, constructability, safety, and efficient use of energy and nonrenewable resources in offshore environments.

OIL AND GAS

Aker Yards ASA, Langsten

Delivering the World's Biggest and Most Advanced Seismic Vessel on Time

Tomrefjord, Norway

Shipyard Aker Yards AS, Langsten has delivered the world's biggest and most advanced seismic vessel on schedule. Aker Yards completed the new flagship Ramform Sovereign for Petroleum Geo-Services. A third-generation Ramform, it is a step forward in seismic acquisition capability. This complex project required a flexible and accurate tool for an exact pipe layout design to fit all equipment inside the hull.

The team used a customization of AutoPLANT Piping for accurate fittings according to yard standard pipe specifications. This included best-practice ship pipe fabrication components, penetration pieces, and special connectors. The challenge was to get details correct, place equipment, and weave the pipe between the steel. The project required more than 3,400 prefab isometric drawings delivered to the client in 22 months.

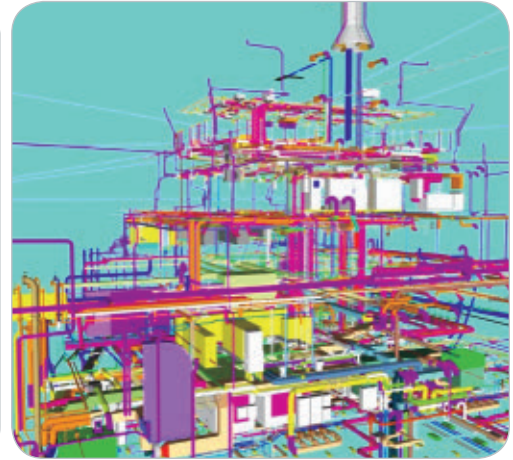

APL

Alvheim Field Development Project

North Sea

The Alvheim project is an oil and gas field in the North Sea operated by Marathon Petroleum. The oil and gas will be produced using a floating, production, storage, and offshore (FPSO) loading unit equipped with the Submerged Turret Production (STP) technology developed by APL. Water depth of the field is 125 meters; design lifetime is 20 years; oil production will be 120,000 barrels per day; and the FPSO storage capacity is 560,000 barrels.

The buoy in this project was the largest that APL has designed, and there were extreme demands for close pipe routing and pipe stress. All piping from the subsea riser to the swivel and from swivel to the ship interface were designed with AutoPLANT, using Isogen for generating isometric drawings. AutoPLANT was also used for the routing of all cable trays and hydraulic tunings.



FINALIST

BP

Tangguh Project

Papua, Indonesia

Located in Papua, Indonesia, the USD 5 billion Tangguh LNG facility will produce 7.6 million tonnes of gas annually. The project included gas production wells and platforms, a gas transmission system, LNG plant, marine facilities, and an airfield. To help meet its PreHSE and Environmental Review for good asset governance, BP required full handover of data and information for operations from multiple EPC contractors in Japan and Indonesia, more than a dozen major subcontractors, and over 300 vendors on nearly 100,000 items of equipment.

To facilitate information management throughout the plant lifecycle, Bentley's Professional Services teamed with BP project information managers to create an information hand-over specification. Project data went through a multistage validation before uploading, consolidation, and final checking in ProjectWise Lifecycle Server (now Bentley Data Quality Server), which then fed the asset and maintenance management systems. Information is now available via web interface for operations and maintenance.



2009 FINALIST

FINALIST

CNGS Engineering

Central Process Platform – V. Filanovsky Oil Field

Caspian Sea, Russia

This RUB 16 billion ice-resistant offshore platform is one of the largest and, due to extreme conditions, most complex projects in the Caspian Sea. In the coldest months, the peak temperature averages -20° C (-4° F) and can drop as low as -36° C (-32.8° F). The support units were designed using 3D modeling to sustain the platform's massive weight as well as prevent ice-load damage.

CNGS Engineering is leading a group of eight subcontractor team members who are using ProjectWise to eliminate file-transfer difficulties. Other software being used on the project includes SACS, AutoPIPE, AutoPLANT Piping, Bentley Piping, Bentley OpenPlant PowerPID, Bentley PlantSpace Equipment, Bentley PlantSpace Piping, Bentley Building Mechanical Systems, MicroStation, Bentley Navigator, and promis•e.

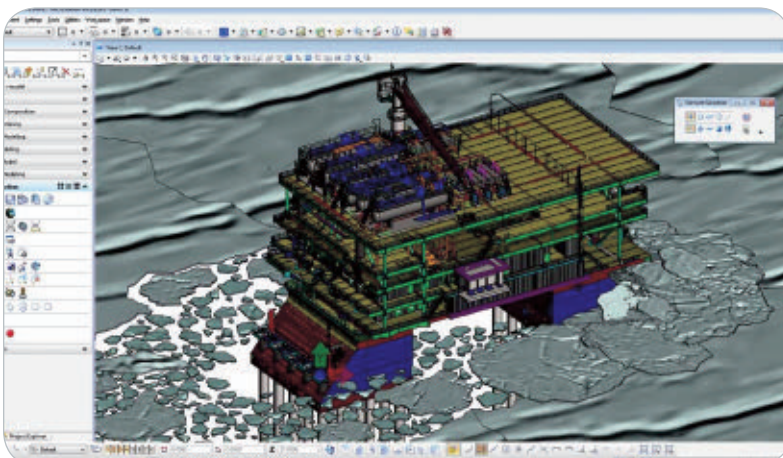

2013 FINALIST

OIL AND GAS

CNGS Engineering

Ice-resistant Offshore Platform LSP-1

Caspian Sea, Russia

FINALIST

Designed for offshore oil field development on the northern shelf of the Caspian Sea, the LSP-1 is an ice-resistant stationary 20,000-ton platform that has a fixed rig and custom-designed steel-plate jacket. The support units were designed to sustain the platform's massive weight as well as prevent ice load damage. Using 3D modeling from design through construction staging enabled CNGS Engineering to design the platform in less than one year.

The company used a variety of Bentley software for the 3D design of the piping systems and steel structures. Steel structures were designed with Structural Modeler; piping systems were designed with Bentley PlantSpace; and other systems were designed with MicroStation. Metal strength analyses were double-checked in SACS, and ProjectWise enabled team members in different locations to collaborate.

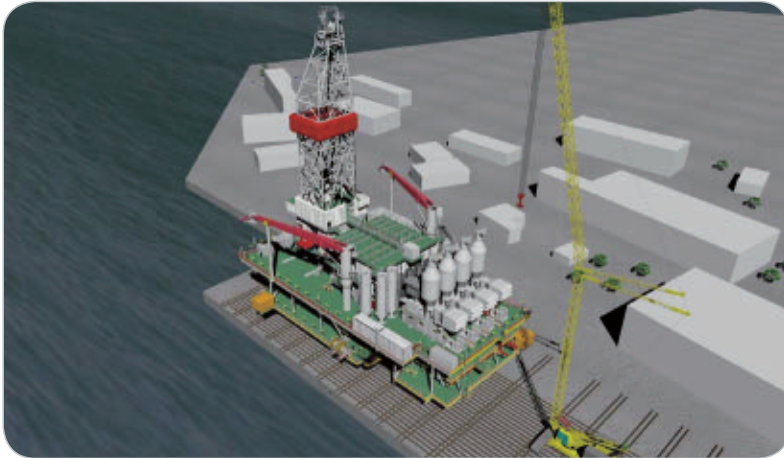

2012 FINALIST

CNGS Engineering

LAM-B Wellhead Platform

Simferopol, Ukraine

FINALIST

The LAM-B fixed platform is located at the Jeytun oil field in the Caspian Sea off the coast of Turkmenistan. It is designed for oil production, preparation, and transportation to the offshore subsea pipelines. CNGS Engineering provided EPC services including project management, engineering design, fabrication of the support jacket and deck sections, and procurement of components including process equipment, and control and power supply systems as well as installation and commissioning of the platform.

MicroStation-based plant design tools created a single 3D model and enabled the automatic generation of the drawings (plans, drawings) and isometric drawings, significantly reducing the time to create these deliverables and material take-offs. Together with ProjectWise, mistakes were avoided relating to usage of irrelevant documents' revisions, and allocation of the right of access resulted in increase of a safety level both commercially and technically.



2009 FINALIST

EDG

Chevron Offshore Platform Project

Gulf of Mexico

EDG helped Chevron cut costs on an offshore platform project with laser-scanning and AutoPLANT. EDG performed laser-scanning to create an AutoPLANT as-built 3D model of the oil platform and reduced project costs by 15 percent. The scope of the job was to scan all areas around a proposed compressor addition to the cellar deck.

EDG needed to scan all options for piping tie-points and proposed pipe routing, capture data to verify spool drawing, scan and verify the position of the new manifold, verify and measure the location of the skid addition, and scan inaccessible outboard beams. The project resulted in accurate and more complete spool drawings for piping, minimized clash detection of proposed piping, fewer field welds, and less operational downtime.

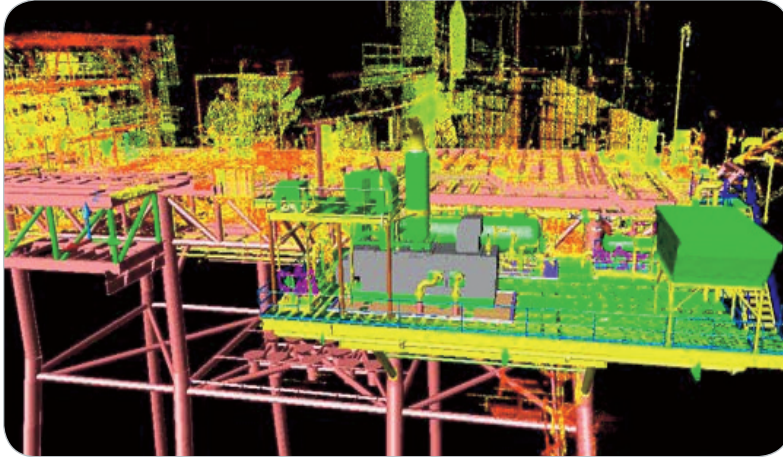

Hojuara As-Built 3D, Ltda.

Change of Gas and Oil Fiscal Survey Equipment

Brazil

This project in Brazil involves pipe and structural modifications made to offshore platforms. The firm used laser scanning and 3D modeling for this revamp and retrofit work to reduce construction rework, risk, and uncertainty. Because most modifications need to be done during a platform shutdown, everything needs to fit right the first time to avoid delays from offshore rework, postponing production start-up.

The greatest impact of Bentley products was the review of the project in 3D during fabrication and before construction. The use of CloudWorx by the design team increased the design quality and avoided many trips to the offshore platform to collect information every time the scope of project was changed.

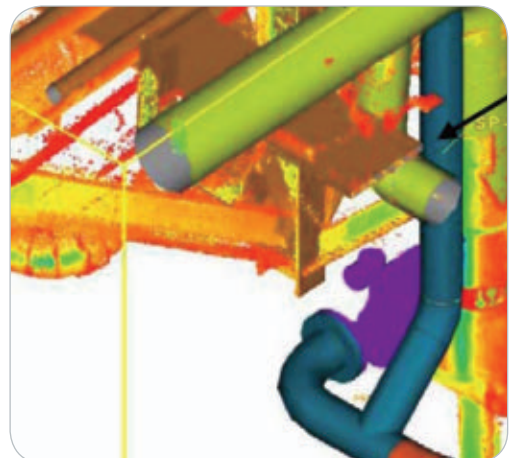
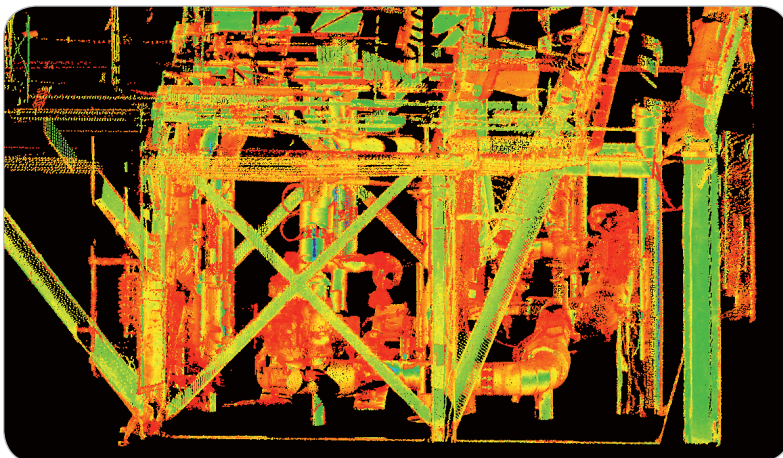

OIL AND GAS

Hyundai Heavy Industry

BP Quad 204 Project

Shetland, United Kingdom

Located on the United Kingdom continental shelf approximately 130 kilometers west of the Shetland Islands, BP's Quad 204 project involves redevelopment of the existing Schiehallion and Loyal fields. This includes replacement of the Schiehallion floating production, storage, and offloading (FPSO) vessel with a new FPSO vessel, addition of production and water injection wells, and numerous subsea infrastructure.

Hyundai Heavy Industry is the engineering, procurement, and construction contractor charged with completing the USD 1.3 billion project in 42 months. SACS was used to model the structure and analyze load combinations for top side and hull appearance design and engineering, which saved significant costs by optimizing the size and depth of sections and reducing the total weight of steel. MicroStation and STAAD.Pro were also used in design and engineering.



Hyundai Heavy Industry

Shwe Gas Project

Rakhine State, Myanmar

Hyundai Heavy Industry operates a 215-acre offshore yard with a gantry crane capable of lifting 1,600 tons. The company was retained as an engineering, procurement, and construction contractor for the USD 1.5 billion, 65-month project to construct facilities for producing, processing, and transporting natural gas from the Shwe gas fields off the coast of Rakhine State in Western Myanmar.

Hyundai performed the primary structural analysis in the early stages of the project. Sea transportation and block handling were key issues in designing the structure for transfer from the yard to the project site. SACS was used for modeling, analysis, and optimization of the structural system under load conditions like transport, installation, launching, floating and lowering, on-bottom stability, block handling, load-out, wave response, fatigue, and earthquake conditions.

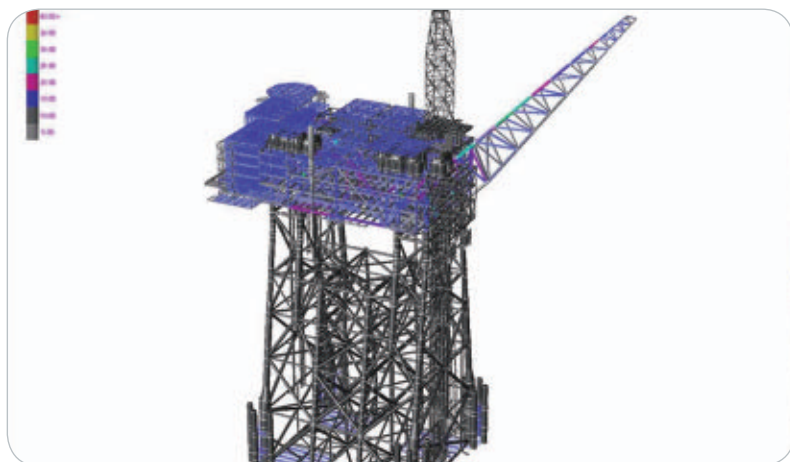

Kavin Engineering and Services Private Limited

FPU JOKOTOLE

Terang Sirasun Batur Field, Indonesia

Kavin Engineering and Services was retained to perform detailed engineering of the complete topside facility for a floating production unit to be stationed at the Terang Sirasun Batur Field in offshore Indonesia. The topside facility contains eight process modules requiring process, piping, mechanical, structural, electrical, and instrumentation. Collaboration among multiple disciplines was the key challenge on this USD 350 million project, along with conforming to client requirements and international standards.

Kavin took advantage of the data-centric approach inherent in AutoPLANT, ProSteel, STAAD.Pro, and Bentley Navigator. Piping, isometrics, and general arrangement drawings were done using AutoPIPE, and structural modeling and 2D drawings for pipe supports, handrails, ladders, and grating were performed using ProSteel. Raceways and instruments were modeled with AutoPLANT Raceways.

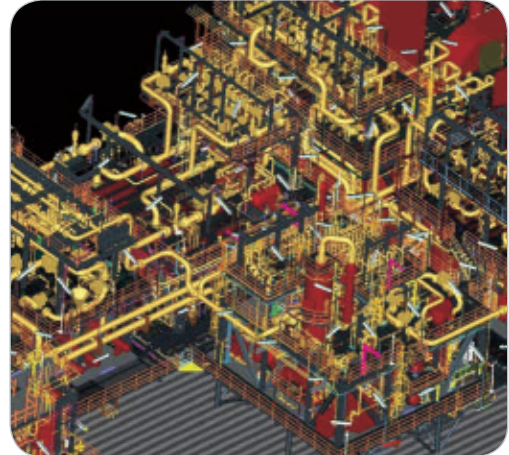
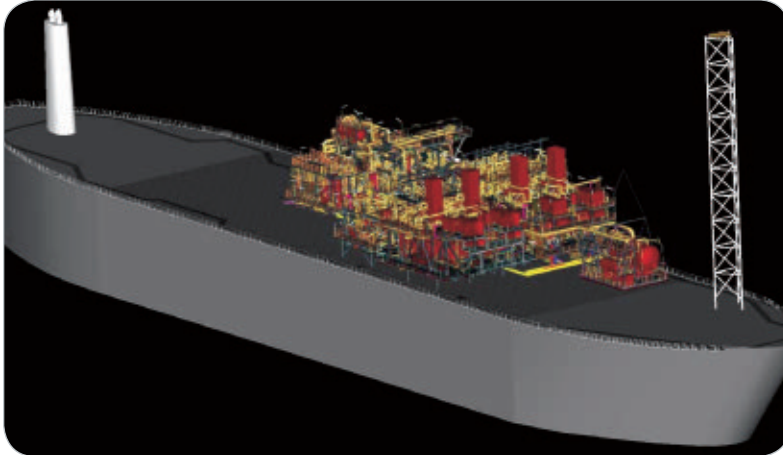

KBR/EOS Oil & Gas Services Joint Venture

The North Rankin Redevelopment Project

Perth, Australia

The North Rankin Redevelopment Project will recover low-pressure gas from the North Rankin and Perseus gas fields off Karratha, Western Australia. The project involves installation of a second platform – North Rankin B (NRB) – with gas compression facilities, low-pressure separators, utilities, and accommodation. EOS Joint Venture has been contracted for the front-end engineering and design, detailed design, and procurement management for the NRB integrated deck float-over topsides and substructure.

To better coordinate information across the many parties and to improve hand-over of information into operations, an information management strategy was put in place that called for a single integrated information set throughout the asset's lifecycle. The ProjectWise Lifecycle Server (now Bentley Data Quality Server) data warehouse serves as the central asset register for the whole NRB facility. The resulting benefits are considerable, with the real-time information and other project tools being made available on the project dashboard/portal, allowing enhanced decision making.

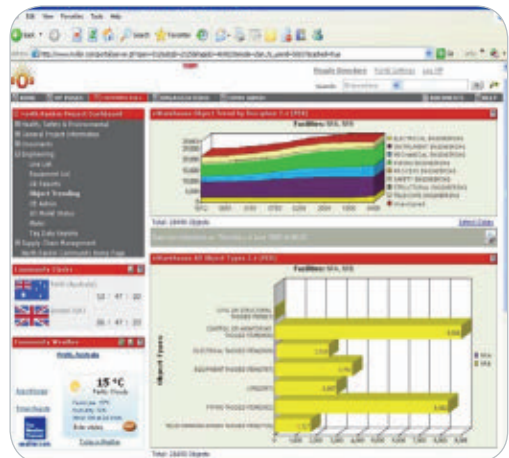
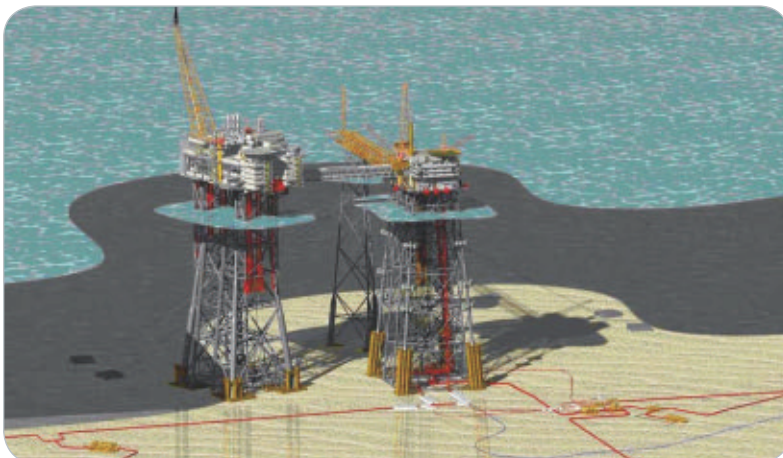

2009 WINNER

OIL AND GAS

Kencana Bestwide Engineering

Front-end Engineering and Detail Design for D1 Cluster Development Project

Bintulu, Sarawak, Malaysia

PCCP Operating Company operates two units of a mobile offshore production unit for the offshore D1 cluster development at Bintulu, Malaysia. Each unit is next to a light-weight structure that supports wellhead and conductors leading to the Dana production wells. The slender structures are distinctive because the diameters are extremely small compared to typical offshore platforms.

With the previous analysis completed at three years of service, Kencana Bestwide Engineering simulated current conditions and assessed the structures at five years of age as part of this USD 16 million project. The firm used SACS to conduct the in-place, lift, dynamic, and fatigue analysis, and validated safety measures in the driven piles through the legs, which also function as conductors. ProjectWise was used to rapidly deploy a project team.

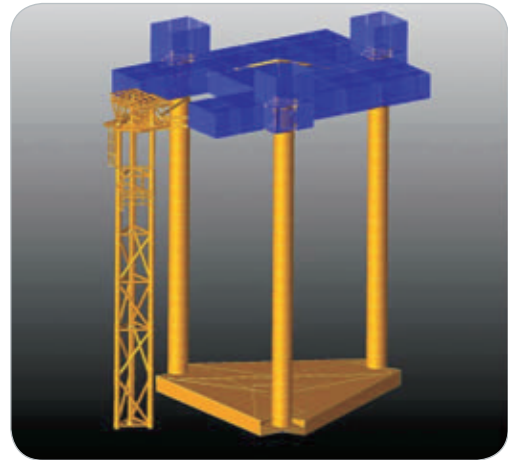
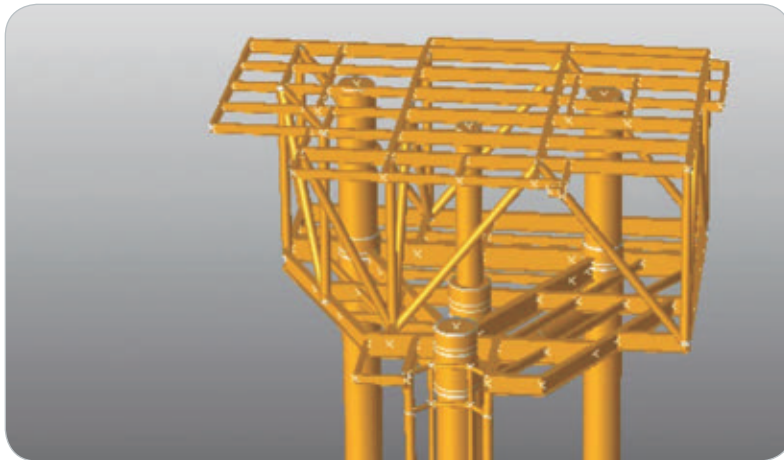

Keppel Shipyard Ltd.

Helipad on FPSO

Singapore

Designing a helipad for a floating production storage and offloading (FPSO) vessel requires consideration of various types of loads, such as the landing load of the helicopter along with vessel motion and wind effects. A crash load is also considered. For this USD 450,000 project in Singapore, Keppel Shipyard identified 126 load cases to analyze.

STAAD.Pro was chosen for modeling, analysis, and design of the helipad because it could process these load combinations within the short amount of time available for the project. The software reduced costs by saving engineering man-hours, improving design quality, ensuring safety standards were met and materials were optimized.

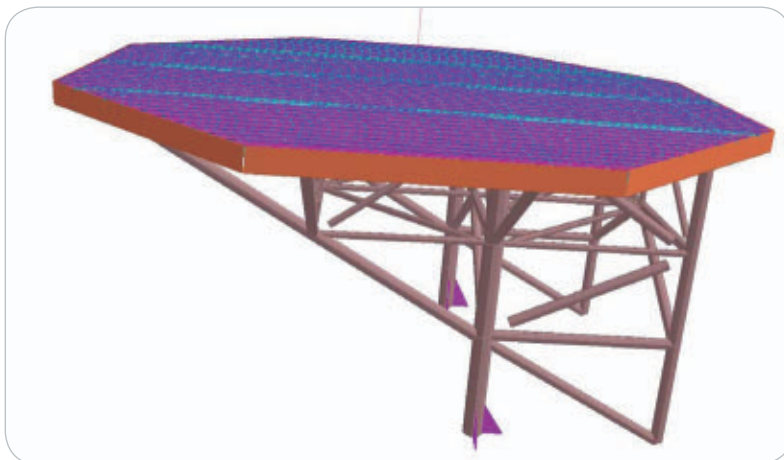

KH Engineering BV The FPSO Mystras Nigeria

AutoPLANT 3D solutions helped complete this ship in record time. KH Engineering designed the process modules and the data management of the 3D design for the entire project, including flare and vessel. KH used Bentley software to complete the 3D model for reviewing clashes, making layouts, generating isometrics, managing materials, and calculating center point gravity.

The full-scale 3D model also integrated data from parties around the world and supported review meetings. The construction phase ran smoothly, and KH Engineering was able to go from design to exploration in 11 months.



Knowsley SK Offshore Production Platform Deluge Skid Manchester, United Kingdom

A USD 2.5 million fire-fighting foam deluge skid for use on an oil-and-gas floating production, storage, and offloading unit was designed to be compact and lightweight yet able to withstand extreme weather of the North Sea and Gulf of Mexico. The challenge was to design the skid to withstand more than 30 load conditions including transportation, rough seas, and high winds.

With a design-build schedule of 26 weeks, Knowsley saved time by exporting piping and structural models from current CAD applications to AutoPIPE and STAAD.Pro. Integrating the piping and structural models allowed engineers to analyze pipe work and steel work interaction under stress. This workflow saved an estimated 220 man-hours and reduced material costs by 10 percent.

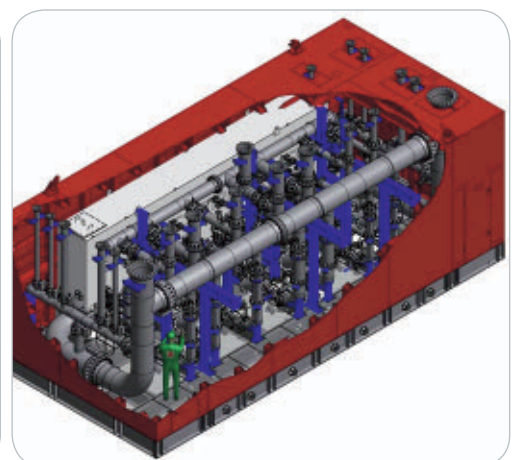

L&T-Valdel Engineering Limited

OSX-3 FPSO Project

Santos Basin, Sao Paulo, Brazil

FINALIST

Located in the Santos Basin off the coast of Brazil, the FPSO OSX-3 will be turret-moored in a maximum water depth of 110 meters, and produce and treat 100,000 barrels per day of crude oil. L&T-Valdel Engineering was commissioned by Modec International to provide modularization design for the FPSO topsides. The challenge was to complete the topside design of 15 modules and 10 pipe racks within 12 months.

The company used SACS for modeling, analysis, and optimization of the FPSO topside structure and STAAD.Pro to design its tertiary steel. The software analyzed the module for all static and dynamic loads observed during pre-service and in-service conditions. SACS improved design accuracy and visual clarity, which saved on-site construction time and reduced steel consumption by 15 percent.



2013 FINALIST

Larsen & Toubro Limited

Assessment of Offshore Platform for Vibration Safety

Mumbai, India

High vibrations on off-shore platforms lead to equipment and structural damage as well as discomfort to workers. Vibration analysis and correction in the design phase avoids costly modifications during commissioning. Larsen & Toubro analyzed vibrations on a gas injection platform housing five reciprocating compressors on a single deck using Bentley's SACS software for analysis and design of offshore structures.

The entire 3,500-ton platform was analyzed for response to mechanical vibrating forces induced by various combinations of compressor operations. SACS was used to model the jacket with pile support, deck, compressor modules, and equipment. The maximum vibration found at various locations exceeded allowable limits so local members were stiffened, and the vibration results were now within allowable limits.

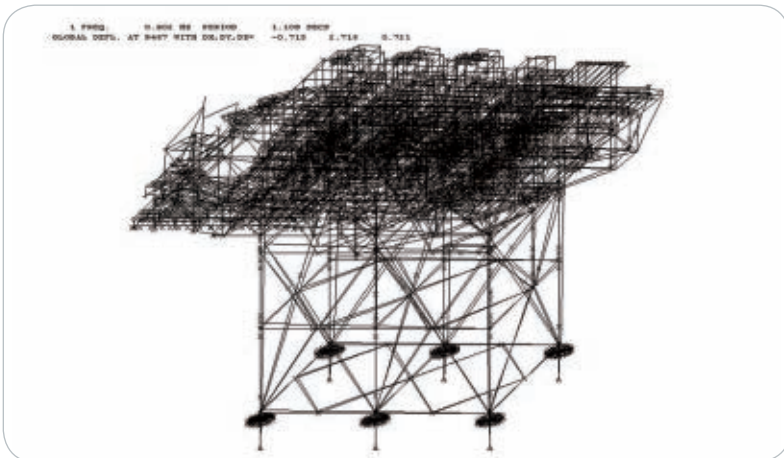

Larsen & Toubro Limited **GDU-GSU Module for MHN Project** Mumbai, India

Installed at the Mumbai High North field off the west coast of India, the USD 925 million process and living quarter platform houses process gas compressor modules, a turbine generator module, gas dehydration unit (GDU), gas sweetening unit (GSU), and living quarters modules. Larsen & Toubro executed the project for Oil and Natural Gas Corporation.

To reduce offshore installation time, the firm combined the GDU and GSU in one module. A new structural configuration of beams, columns, and vertical braces was required to accommodate the units' different geometries. SACS was used to perform pre-service analysis for lift, load-out and transportation; and in-service analyses for operating and extreme conditions. The optimized module configuration reduced costs for materials, offshore lifts, and barge days.

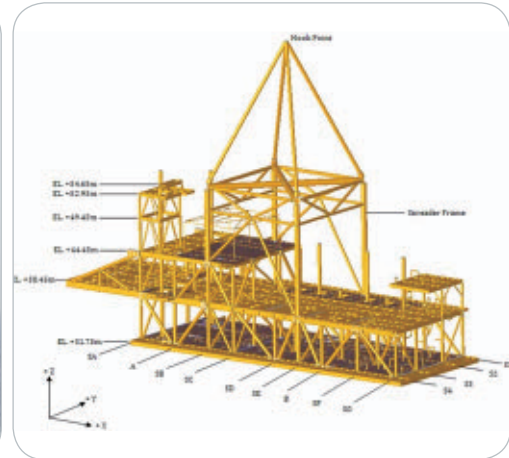

Larsen & Toubro Limited **NORC—PGC Module** Mumbai, India

Larsen & Toubro's engineering team undertook a process manufacturing project in Mumbai, India, with the challenge of modeling the piping systems and supports for the offshore platform module within a limited space. The project team generated 3D models for delivery to the client for use during operations and maintenance, including future retrofits and modifications.

Larsen & Toubro used MicroStation, Bentley Navigator, and ProjectWise i-model Composer to accelerate information sharing and communications across project teams. The engineering practices established over the years on numerous similar projects helped the Mumbai team to cope with the challenges presented by this project.

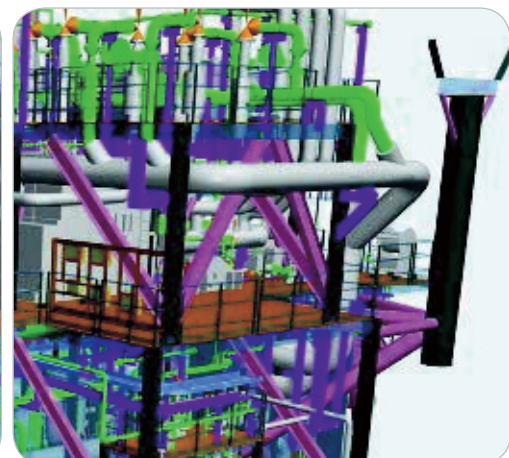
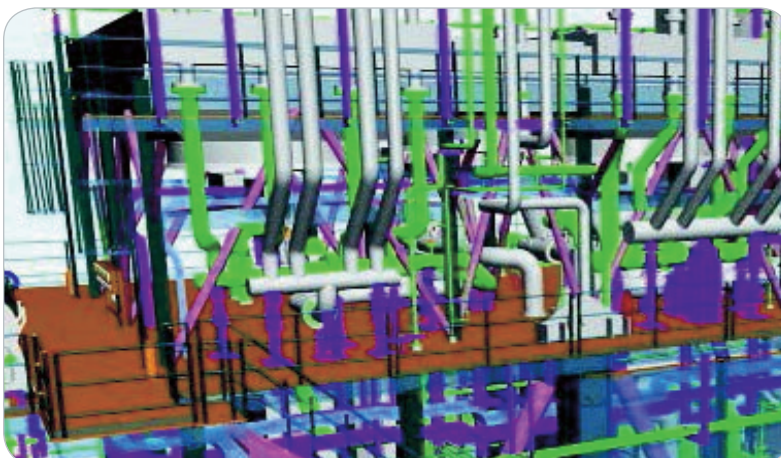

OIL AND GAS

M7 Offshore

Bergesen Worldwide Offshore – Bilabri – FPSO Upgrade

New Zealand

Whakaaropai is a Suezmax-sized vessel operating on the Maui B oil field off New Zealand for Shell Todd Oil Services Ltd. Built in 1976 and converted in 1995-96, she was renamed Bilabri and upgraded as part of the new project to engineer a new test separator module and a riser balcony.

Tying a new module into an existing one of this size is normally a complex engineering task, but a model was created using Bentley software with accuracy down to a millimeter by scanning the site and obtaining a point-cloud model. CloudWorx converted the interface sections into CAD elements to be imported into the CAD model. The firm also used Bentley PlantSpace.

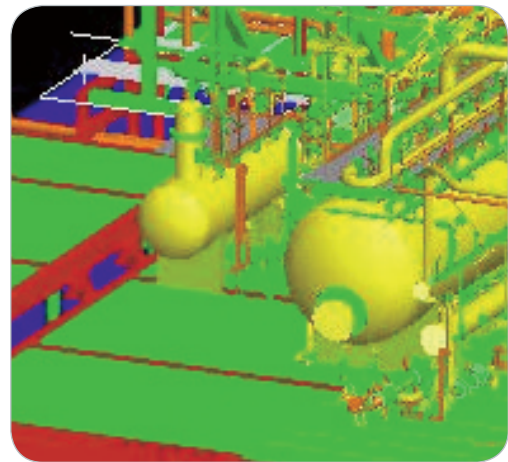
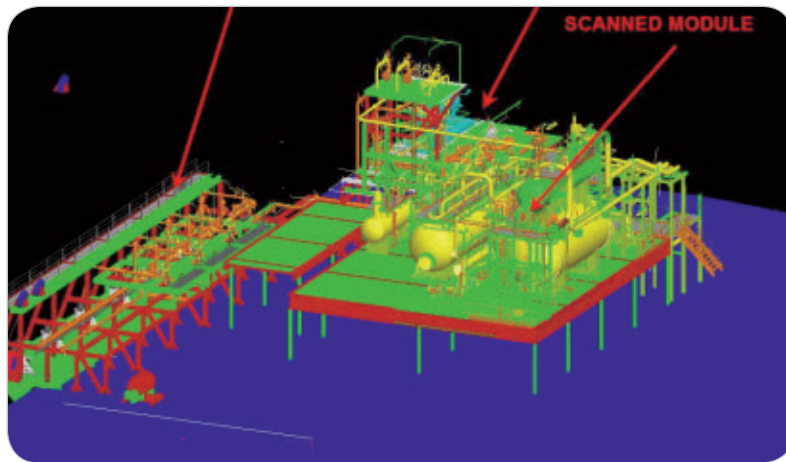

Oil and Natural Gas Corporation Limited

HC Platform: ONGC

Mumbai, Maharashtra, India

The engineering challenge on this INR 1 billion project in Mumbai, India, was the survey and analysis of an underwater platform to determine the extent of damage and need for retrofit. Because of approaching seasonal monsoons, temporary measures included adding a strop system to hold the framing intact, detaching a critical riser, and installing additional clamps to avoid any vortex formation for risers.

The impact of a collapse would have been catastrophic both environmentally and financially. Oil and Natural Gas Corporation (ONGC) used SACS to evaluate the HC platform and perform ultimate, fatigue, and pushover analysis. The firm then recommended measures necessary to ensure that the structure would meet storm conditions with no major plasticity or joint failures.

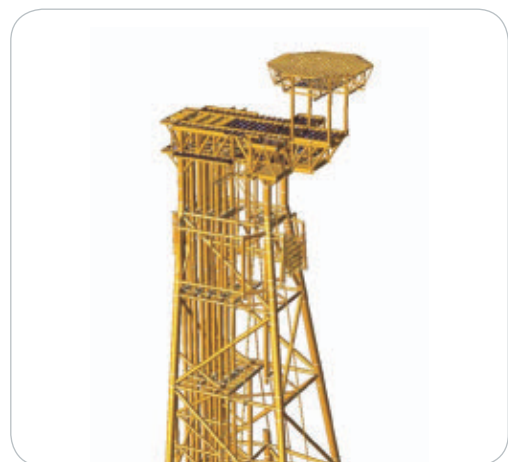

HONORABLE MENTION – INNOVATION IN OFFSHORE ENGINEERING

Oil and Natural Gas Corporation Limited – IEOT
Guyed Tower Platform Concept for Marginal Fields
 Mumbai, Maharashtra, India

Any oil field nearing the end of its commercial life is defined as a marginal field. Oil and Natural Gas Corporation – IEOT embarked on a study of marginal fields on the west coast of India. Using SACS, the study provided conclusive data that guyed towers are a suitable alternative to the conventional jacket structures of traditional offshore structures.

Extremely cost effective, a guyed tower consists of a slender steel space frame with vertical forces on the platform taken by a foundation base. With the base partially penetrating the sea bed, the support structure is held upright by several guy lines that run to clump weights on the ocean floor. From the clump weights, the lines then run to conventional anchors to form a dual stiffness mooring system.

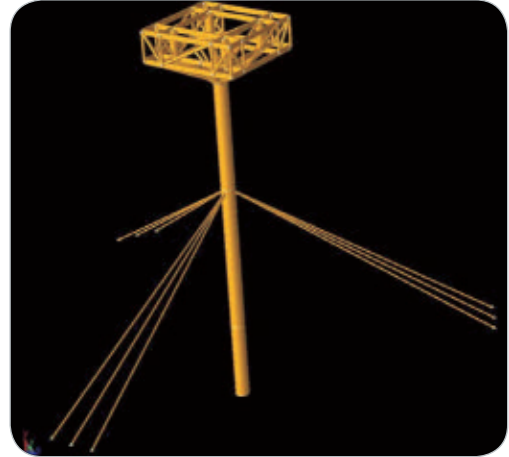
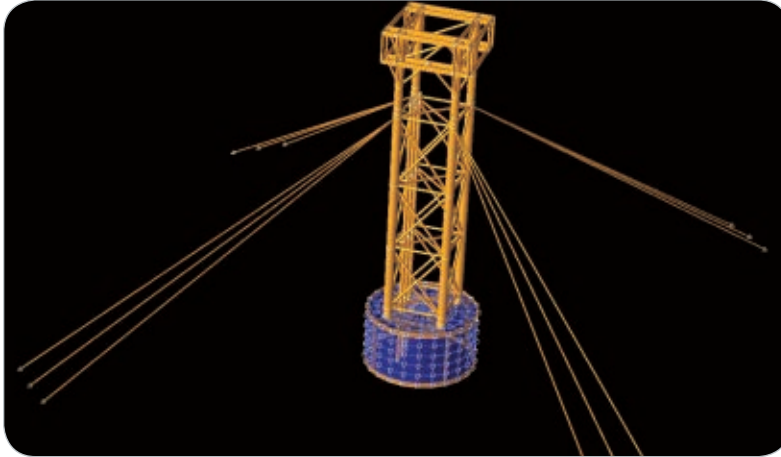

WINNER

Petrobras SA
SGO Project – Petrobras Subsea Asset Tracking
 Brazil

The Obstacles Management System (SGO) is a USD 20 million project in Brazil dedicated to the systematic mapping of surface and deep-sea obstacles. A growing level of offshore activity in the Campos basin increased the number of sea obstacles, and Petrobras saw the need for a greater degree of planning. The company first commissioned a survey ship to map the entire basin, and the initial database was used to generate a comprehensive map of obstacles.

Developed using MicroStation, the new system enables a user to simply select an area of interest and all surface and deep-sea obstacles can be quickly visualized in 3D, facilitating fast determination of obstacle characteristics. Savings from the use of this system total as much as USD 100,000 per day by reducing the time required to install pipelines by up to 40 percent.

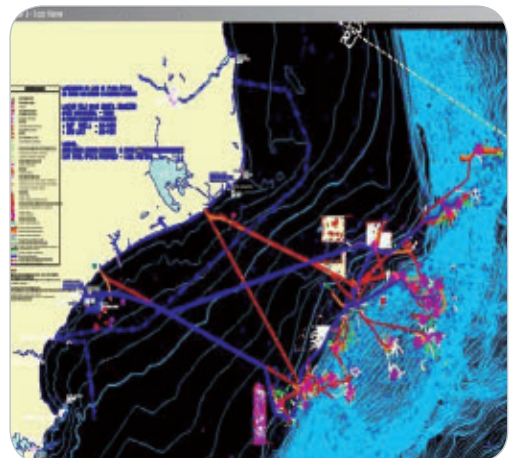

2007 WINNER

Petrofac Brownfield

CNS Subsea Tieback and Gas Compression Module

United Kingdom



The U.K. project consists of a new 1,200-metric-ton module, brownfield modifications, and a subsea tieback to the host platform. Petrofac Brownfield used Bentley AutoPLANT's 3D software and laser-scanning techniques to capture as-built plant information. The solution provided a 10 percent savings in onshore piping man-hours.

This reduction in offshore survey time has been estimated at trading off eight days of scanning against 1,000 piping survey hours. This equates to a direct project saving of GBP 20,000, with the more subtle benefit of much-reduced offshore contact hours (helicopter flights and living on an operating installation), enhancing safety for the workforce.

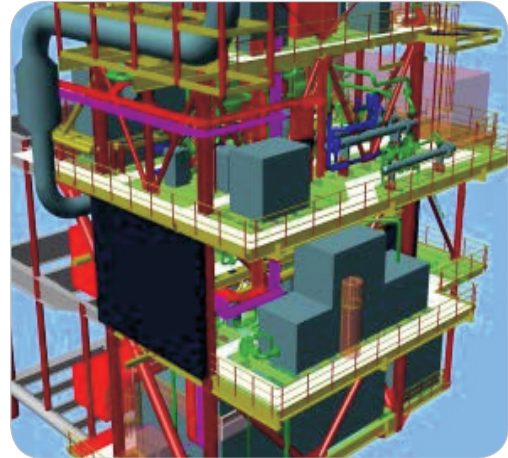
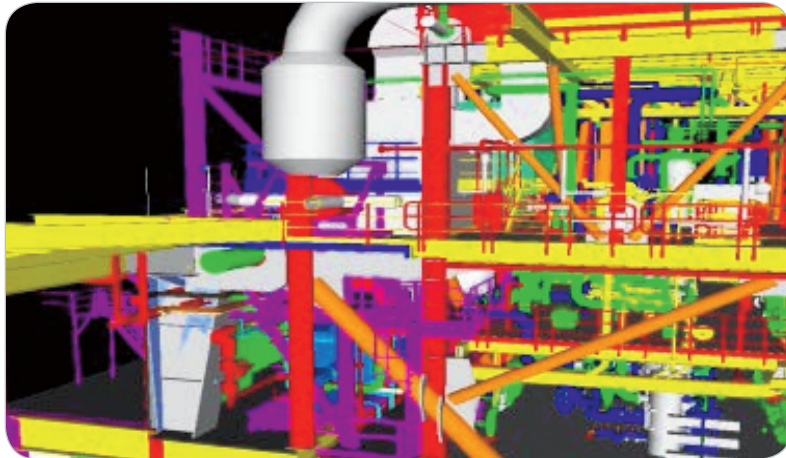

2006 WINNER

Petrofac Brownfield

Documentation Management Systems Upgrade

Aberdeen, United Kingdom

Based in Aberdeen, United Kingdom, Petrofac Brownfield upgraded its existing document management systems to gain control of all work-in-progress documentation and achieve its strategic objective of working globally and collaboratively. The project was designed to provide operational efficiencies for the company, its clients, and subcontractors on projects around the world.

The two-part implementation included a document control server and work-in-progress document management. ProjectWise facilitated the use of 3D models in disparate locations, and after three months of operation, the firm was able to reduce its engineering norms by 5 percent on deliverables. This reduction was achieved through efficiencies in the document lifecycle.



Projemar S.A.
FPSO P-47 Conversion
 Rio De Janeiro, Brazil

Petrobras Netherlands B.V. (PNBV) awarded Ultratec a contract for the conversion of the existing FSO Petrobras 47 (FSO P-47) unit into a floating, production, storage, and offloading (FPSO) P-47. The new unit will be located at Marlin Field in Campos Basis, Brazil, and is designed for operation in a water depth of 189 meters. This contract comprises all services necessary to convert the FSO P-47 into an FPSO P-47.

Ultratec awarded to Projemar a contract for the complete engineering and design services comprising topsides and marine/ship services and for technical assistance at the construction site. For conversion to FPSO P-47, an oil process and water treatment plant (process plant) will be added to FSO P-47. It will comprise equipment, control, automation and utilities for oil and water treatment, support structure, hull reinforcements, and handling systems for equipment.

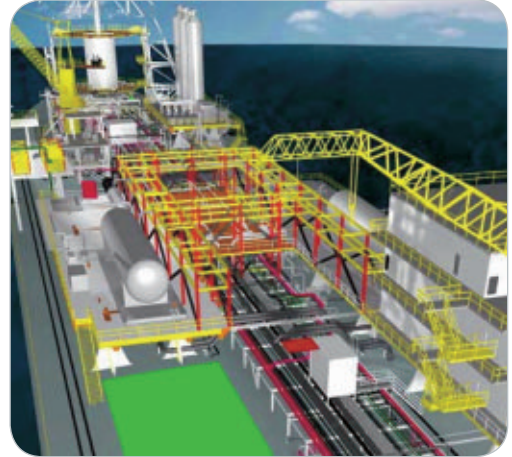

WINNER

PT McDermott Indonesia
Cuu Long Su Tu Vang Project
 Mekong Basin, Vietnam

The Su Tu Vang Central Processing Platform off the coast of Vietnam was a fully integrated engineering, procurement, construction, and installation project that included a 4,400-ton, eight-leg jacket; 17,000-ton floatover topsides; 66-person, 1,323-ton living quarters; pipelines; umbilicals; and manifolds. The challenge was to complete the project within 10 percent of the authorized budget while maintaining the highest safety record.

ConstructSim facilitated the fast-tracking that allowed concurrent overlapping design and construction. In just six months from contract award, the primary steel drawings were released for construction. Taking advantage of steel delivery earlier than anticipated, the fabrication schedule was moved forward by one month. Twenty-four months from the first steel-cutting ceremony, the project produced its first oil.



2010 WINNER

Qatar Petroleum

Creation of Intelligent As-Built Models of Offshore Facilities Using a Combination of Terrestrial Laser Scanning and Verified Existing Engineering Drawings

Doha, Qatar

WINNER

Qatar Petroleum facilities on three offshore platforms and one island had no as-built master engineering records. This USD 18.9 million project created a consolidated as-built 2D/3D master engineering record for asset management and maintenance. Qatar Petroleum converted all P&IDs to intelligent 3D models and extracted and updated as-built inspection isometrics, piping general arrangement drawings, and layout drawings.

Qatar Petroleum reverse-engineered the facilities through 3D laser scanning, intelligent modeling, and 2D drawing verification. The scalability and intuitive interface of AutoPLANT products allowed for quick deployment. PlantWise saved time extracting 2D drawings. Bentley Navigator, ProjectWise, and Bentley i-models facilitated reviews and data sharing among contractors. Qatar Petroleum completed the project in 43 months.

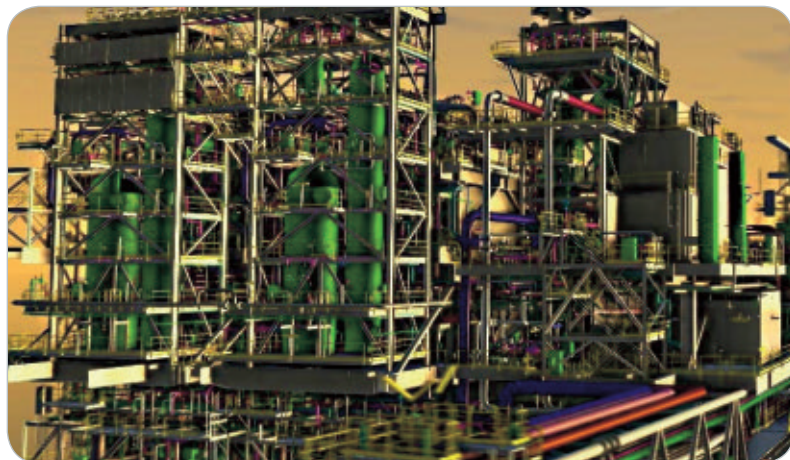

2011 WINNER

Quip S.A.

Offshore Platform P53

Brazil

Located 120 kilometers off the Brazil coast and moored at a depth of 1,080 meters, this floating producing unit (FPU) platform will have the capacity to produce and process 180,000 barrels of gas a day and 6 million normal cubic meters of gas. The FPU will not stock the produced oil and gas in its tanks, as they are immediately transferred to other platforms.

Quip developed the FPU P53 platform and presented all review sessions using Bentley Navigator, which gave the engineers and technical team access to 3D visualization so potential problems could be identified in advance. This was the first 3D visualization initiative in Brazilian offshore projects and now other Brazilian EPCs are starting to adopt this concept.



Ramboll Engineering Consultancy Services India Pvt. Ltd.

Offshore Platform As-built Model

Doha, Qatar

Ramboll Engineering Consultancy Services was retained to create an as-built model of an offshore platform. 3D laser scanning was used as a cost-effective way to acquire as-built documentation of the complex structure and buildings. The laser technology captured point-cloud data on physical objects such as structures, pipe works, and mechanical components.

Point-cloud data was imported to MicroStation to be digitized within a tolerance of a few millimeters. The result for Ramboll Engineering was a highly accurate as-built model of the offshore platform produced at significantly less cost than other methods.

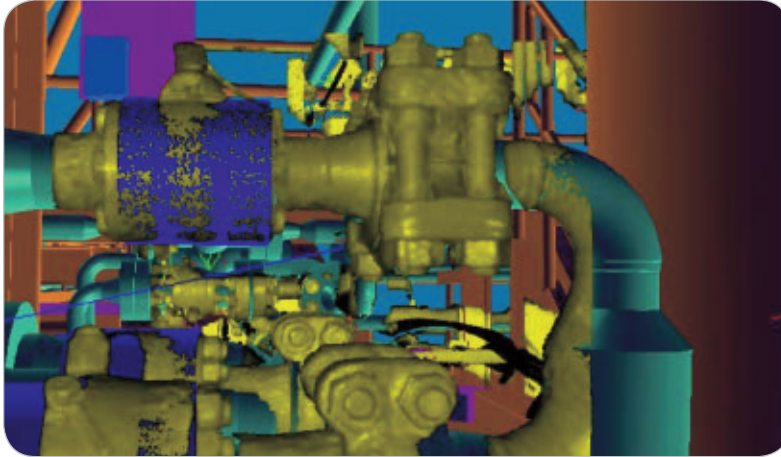

Ramboll Engineering Consultancy Services India Pvt. Ltd.

Small Bore Branch Support

Doha, Qatar

Ramboll Engineering Consultancy Services is a multidisciplinary engineering, design, and consultancy company working across seven markets: buildings, transport, environment, energy, oil and gas, telecoms, and management consulting. The goal for this project was to design a small bore branch support system that minimized the number of supports to the small bore.

To accomplish this, it was critical to visualize the support shown in the 2D drawings. Ramboll Engineering used MicroStation to model and visualize the small bore and its supports. Supports of variable size were set up for parametric modeling. This enabled the engineers to optimize the design and perform clash detection during design review.

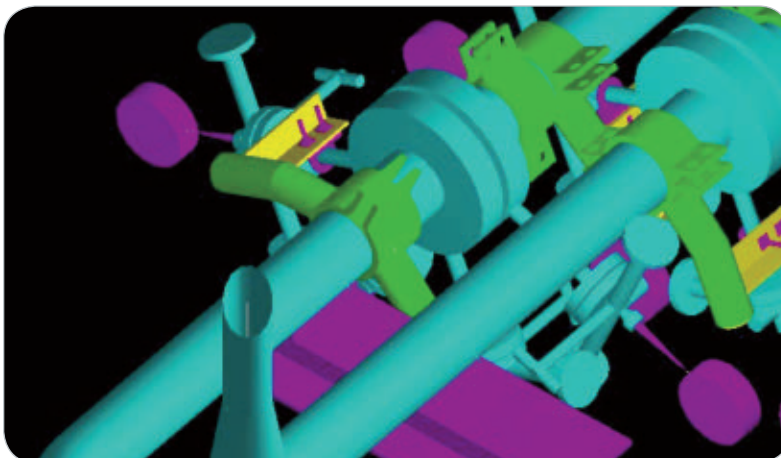

Ramboll Future

SSP300 Piranema FPSO

Brazil

The SSP300 Piranema, a floating production, storage, and offloading (FPSO) vessel, will be situated off the coast of Brazil. Most FPSOs are built like tankers, but the 64-meter diameter, circular SSP300 is a new concept. It is being designed in Norway, and the hull is being constructed in China and shipped to Holland – where it will be assembled and connected to the topside process and utility systems. The complete FPSO will be towed to the field.

Ramboll Future finds a 3D multidisciplinary CAD system essential in all phases of a topside engineering project. In the concept phase, the model is used for space allocation and presentations. In the engineering phase, all engineering and clash detection is done in the model by the area disciplines (piping, structural, and so on). The system disciplines (process, safety, HMS, and so on) review the model in ProjectWise Explorer to verify the design.

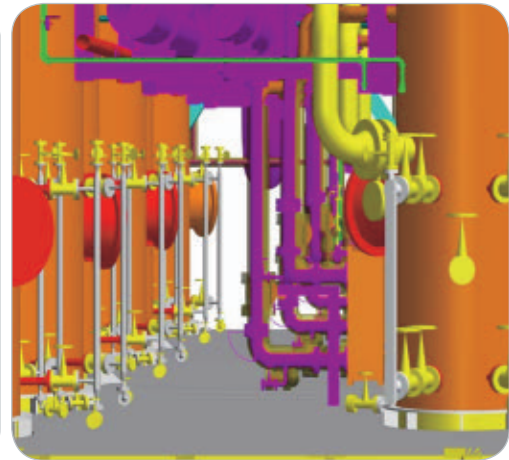
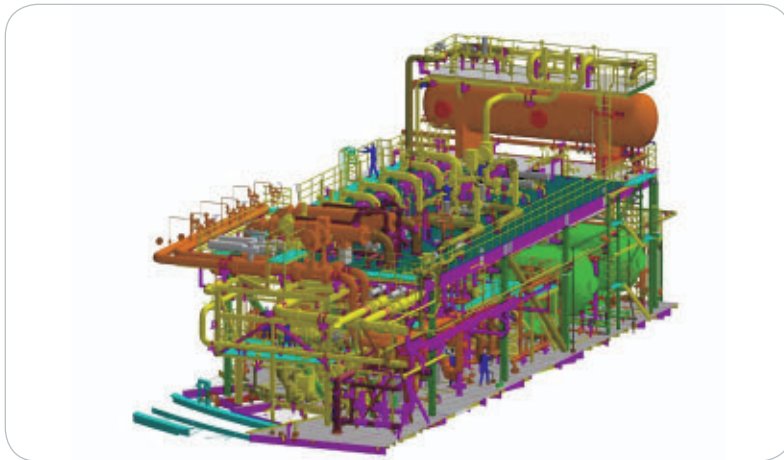

Rishabh Software Pvt. Ltd.

Hebron Topside Project

Atlantic Ocean, Canada

Hebron is a heavy oil field located in the Atlantic Ocean, 350 kilometers southeast of St. John's, the capital city of the Canadian province of Newfoundland and Labrador. Utilizing WorleyParsons' expertise in sub-Arctic float-over topsides at water depths of 92 meters, Rishabh Software was contracted to design the metering skids for the piping and structural disciplines.

Rishabh Software – an ISO-certified piping and mechanical engineering house – used ProjectWise to integrate a design team distributed over multiple locations, and ProStructures, AutoPLANT Piping, and AutoPLANT Equipment for the offshore platform in which the fiscal metering skids needed to be employed. The firm detailed the skids and provided all drawings and models in native format so the client could design them using ProSteel. The 3D models created reference data that helped avoid clashes.

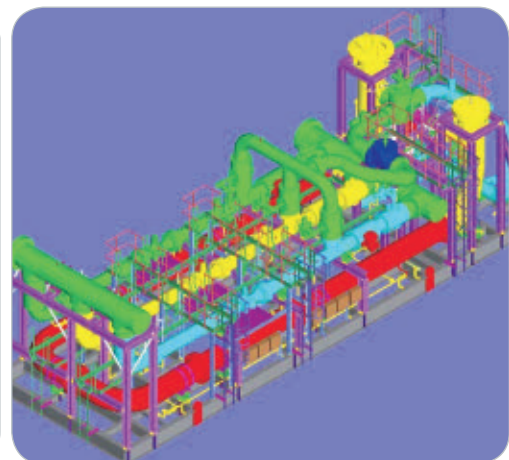
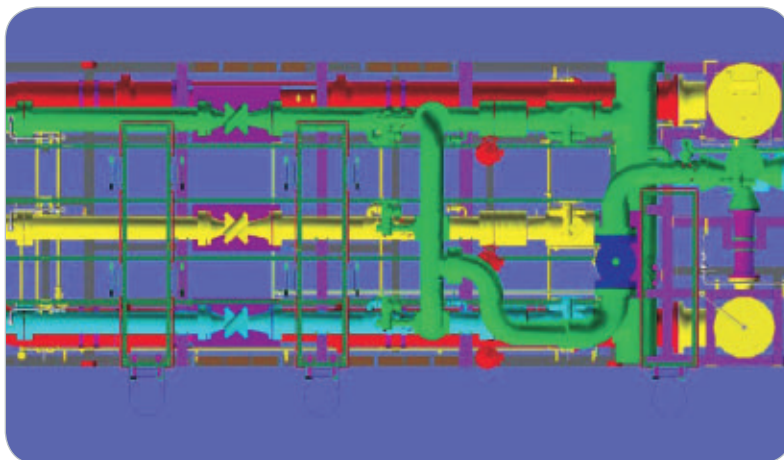

RNZ Pegasus Asia Pacific Sdn. Bhd.
Pipeline and Riser Detailed Design Engineering
 West Belunut, Terengganu, Malaysia

Newfield Peninsula Malaysia is the operator of Malaysia Block PM323, located in the Malay Basin in the South China Sea. Two additional offshore platforms are planned as part of the oil field expansion. One, the West Belunut Wellhead Platform, is unique because it consists of a four-inch pipeline piggy-backed onto the 10-inch pipeline. The challenge was to simulate the support conditions at the piggy-back blocks along the pipeline.

Using AutoPIPE, RNZ Pegasus Asia Pacific designed the riser and evaluated the static stress level within the riser and pipeline system. In addition, the team simulated the effects of pressure at pipe bends and closed ends, thermal expansion, applied loads, support movements, pipe/soil interaction, pipe/support friction, support restraints, and environmental loads. AutoPIPE analyzed the two pipelines in one 3D model.

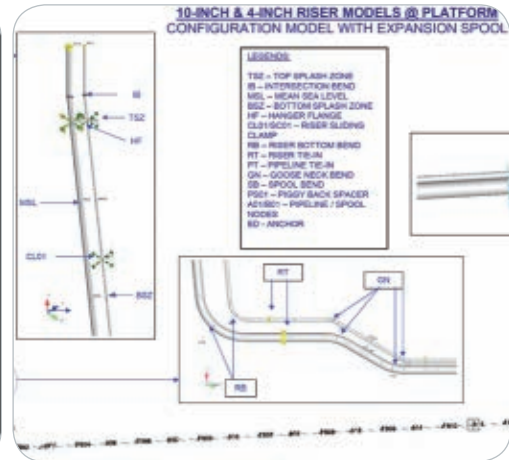
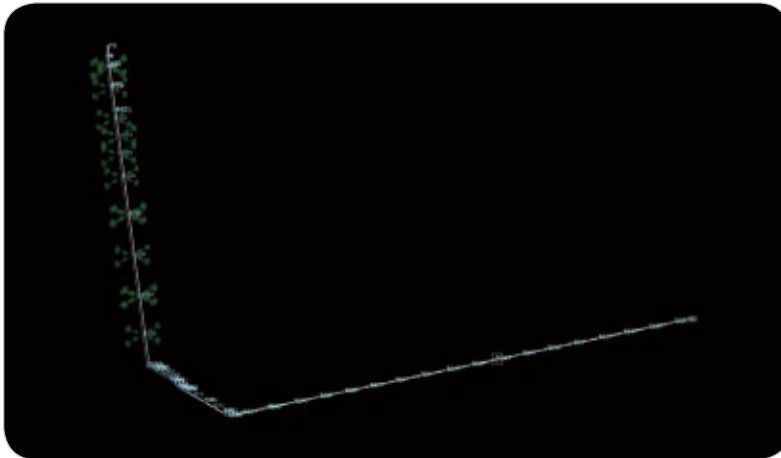

WorleyParsons Services Pty Ltd.
Victoria Platform Development
 Western Australia

To exploit marginal oil field reserves, a cost-effective wellhead facility was developed by WorleyParsons. Both the substructure and deck were fabricated in Kwinana and transported to Dampier for shipment to the offshore site for installation. The design team worked solidly for 10 weeks to achieve AFC issue of all documentation. The fast-track nature of the project meant that drawings were progressively issued to the fabricator, who completed fabrication and delivered the jacket and topsides to

Dampier. The platform sits in about 6 meters of water and uses a three-legged jacket to support the topsides. The production will contribute 16,000 barrels of oil per day to the Western Australia economy, which amounts to roughly USD 40 million in revenue. Bentley software used on the project included Bentley Piping, Bentley Cable Tray, and Bentley HVAC.

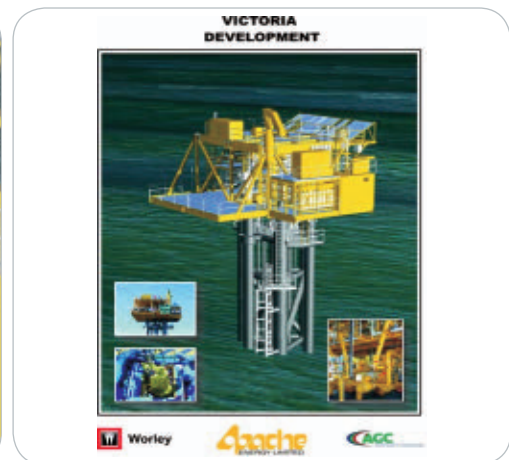
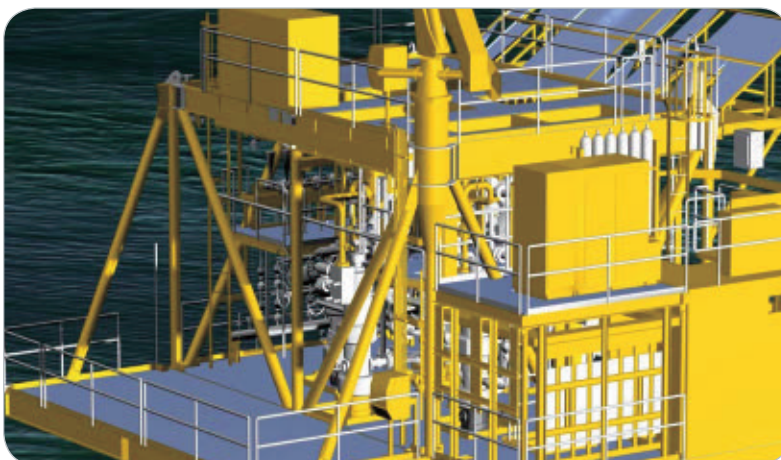

Zentech Engineering Co., Ltd.

Gumusut-Kakap Semi-FPS Project

Pasir Gudang, Johor, Malaysia

The fabrication and assembly of floating offshore structures have traditionally been carried out in the dry dock of a shipyard by stacking unit blocks sequentially from lower to upper levels. The use of dry dock facilities, however, depends on dock schedules and tight fabrication processes of the yard; and thus it is typically quite challenging to quickly incorporate design modifications required by a client.

For this USD 1.6 billion project for MMHE in Malaysia, Zentech Engineering used SACS to coordinate the superlift structural design across multiple disciplines. SACS ensured safer integration of the offshore floating structure with a fully coordinated design that met the construction schedule while maintaining high quality standards. The 3D model was a breakthrough for the client relationship and produced a significant gain in productivity.

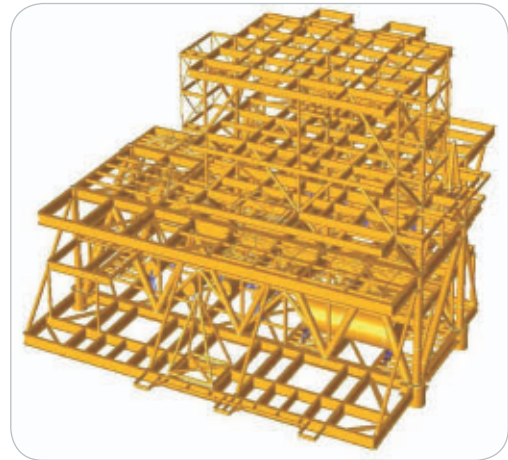

Zentech Engineering Co., Ltd.

Modularization Design for Ruwais Refinery Project

Geyjea, South Korea

The Abu Dhabi Oil Refining Company (Takreer) Ruwais refinery expansion will increase Takreer's refining capacity by 417,000 barrels per day and double its production of transportation fuels. The USD 10 billion project is being developed in eight packages, including crude distillation and sulphur recovery facilities, a residue fluidized catalytic cracker, off sites and utilities, storage tanks, infrastructure work, marine works, and two packages for site preparation.

Zentech Engineering provided modularization design and construction for a USD 3.5 billion package. The company used SACS to design pipe support for the offshore structure. The software analyzed static and dynamic load conditions for load-out, transportation, and lifting as well as performed safety checks. SACS improved the design process and saved on-site construction time.



WINNER

Zeton Inc.

Modular GTL Commercial Demonstration Plant

Aracaju, Brazil

Zeton designed and built the world's first modular gas-to-liquids (GTL) commercial demonstration plant using Compact GTL's mini-channel reactor technology. The USD 20 million plant incorporated all aspects required for commercial application in treating gas at remote and offshore oil fields. Access to a real-time 3D model during fabrication improved accuracy and reduced rework.

AutoPLANT provided the robust 3D plant modeling solution required to scale GTL technology from pilot to commercial and allowed team members on four continents to work together to resolve issues related to design of a compact, modular GTL plant. In addition to AutoPLANT, the 3D design was completed using ISOGEN for isometric piping drawings, AutoPIPE for pipe stress analysis, and ProStructures for structural steel design.



2012 WINNER







Vessel

Servicing the offshore infrastructure required by the oil, gas, and wind energy industries combined with the ongoing demands of the marine industry, challenges naval architects to produce innovative, effective vessel designs. The projects in this category highlight the innovative application of naval architecture technology to design offshore and marine vessels to the highest standards of efficiency, safety, and constructability.

VESSEL

Francis Design Consulting SARL

Villa 567 Cote d'Azur

Chateaufneuf de Grasse, France

Superyacht designer Martin Francis of Francis Design Consulting designed a 100-meter motor yacht using 3D modeling for vessel design and analysis. The EUR 250 million project involved conceiving and modeling the hull form and then exporting the data file to MicroStation for the remaining work.

The 3D functionality of MicroStation and its Luxology rendering engine enabled the entire yacht to be designed in 3D. The Luxology rendering engine allowed rapid visualization of the vessel design. Embarking from the French Riviera, the Villa 567 Cote d'Azur will sail the oceans of the world.



Incat Crowther

Bhagwan Dryden

Dampier, Western Australia, Australia

Incat Crowther collaborated with Bhagwan Marine and Neptune Marine Services on this AUD 30 million project in Dampier, Australia, to develop a first-of-a-kind, integrated catamaran. The goal was to design one vessel able to perform six functions: dive support, geophysical survey, geotechnical survey, cargo transport, hyperbaric rescue, and safety standby. Innovative design reallocated compartments and respecified the flexible, high-redundancy propulsion system.

What sets this vessel apart from its peers currently operating in similar environments is the combination of capabilities consolidated onto a singular purpose-built platform. Bentley's Maxsurf Modeler and Maxsurf Stability Enterprise were integrated into the design process to determine the overall intact and damage stability of the vessel, which enabled the team to develop 3D models of various hull-form and compartment configurations.



FINALIST

STX Shipbuilding

Virtual Tour

Korea

In Korea, STX Shipbuilding is designing four liquefied nitrogen gas vessels for ship owners abroad. Using MicroStation, the firm will create a 3D model of each vessel before it is completed. Simultaneously, this virtual tour will be made available to the engineering staff so they can continue to move forward on the design.

MicroStation creates a virtual-reality model of the vessel on a single platform, ranging from the initial designing stage to the final construction phase. Now not only designers, but also the engineers and owners, can work on a single platform for different aspects of an engineering file. In addition, the cost of creating a physical vessel mockup is saved because the vessel is modeled in three dimensions.

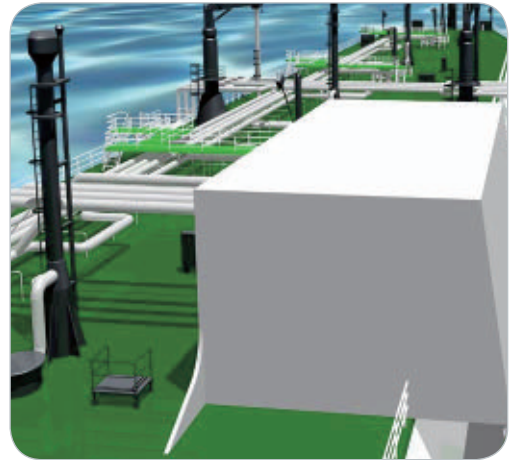
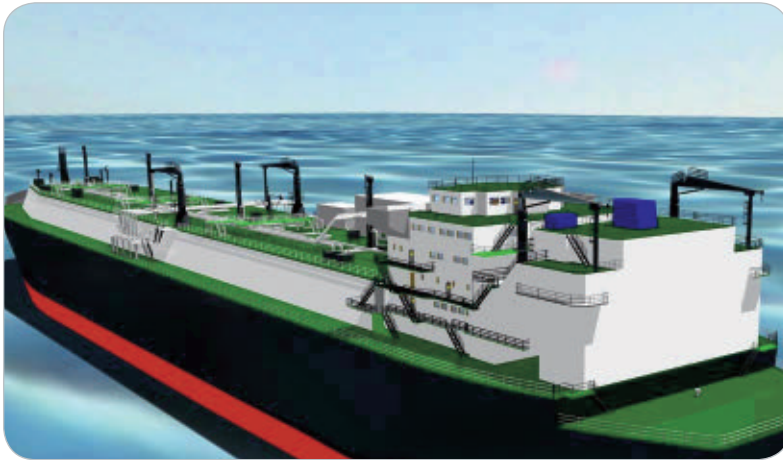

2007 FINALIST







Wind

The increasing demand for renewable energy sources has driven the rapid expansion of offshore wind farms. The projects in this category represent the creative use of design technology to meet the engineering challenges of designing support structures for offshore wind turbines.

WIND



Ecofys Netherlands B.V.
Wind Turbine Test Site
Netherlands

FINALIST

Ecofys owns and operates a wind energy test site with capacity for nine 2.5 megawatt turbines. Ecofys implemented and configured AssetWise at Test Site Lelystad in the Netherlands to demonstrate the benefits of asset information management for offshore wind farms. Using Bentley Geo Web Publisher for the front-end, AssetWise improved visualization and control of assets in the context of site layout, project, or procedure.

AssetWise produced direct time savings by synchronizing asset information, streamlining workflows, and reducing delays and other consequential effects of poor asset information. Based on a hypothetical offshore wind farm with 30x3 megawatt turbines, Ecofys estimates a total cost savings of USD 4.3 million over the 20-year lifetime of the farm.



SPECIAL RECOGNITION AWARD WINNER – INNOVATION IN ASSET PERFORMANCE MANAGEMENT

2012 FINALIST



Guodian United Power Technology Co. Ltd.
SACS Application in the Offshore Wind Turbine Foundation and Substructure Design
Beijing, China

With the development of offshore wind power, the design technology of offshore wind turbine foundations and substructures has gained attention around the world. Since wave/current loads borne by offshore wind turbines and seabed geological conditions are the same as those for a fixed offshore platform, the same software can be used in the design of offshore wind turbine foundations and substructures.

For this CNY 5.3 billion project, Guodian United Power Technology used SACS to design a six-megawatt offshore wind turbine at the Leting wind farm in Beijing, China. The wind farm will include a total installed capacity of 4,400 megawatts, starting off with 300 megawatts during the first phase. Using SACS, the firm calculated and analyzed 459 fatigue working conditions in only 30 hours.

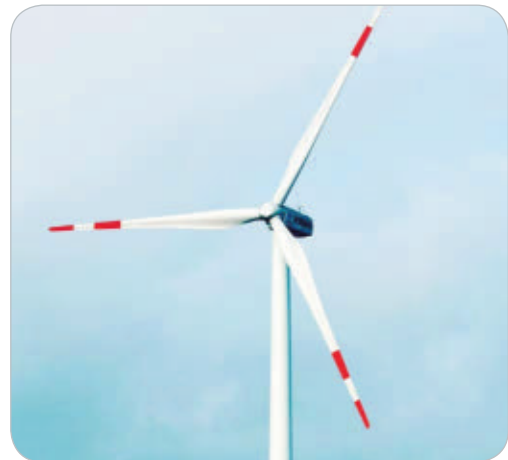

HONORABLE MENTION – INNOVATION IN OFFSHORE ENGINEERING

ISC Consulting Engineers A/S
Upending Hinge Installation of Mono Piles
 United Kingdom

ISC Consulting Engineers offers services within all areas of construction, process engineering, technical systems, oil and gas industry, infrastructure, and IT, which include the design of tools for use in the installation of offshore windmills. The upending hinge for installation of mono piles was designed to ensure lateral guidance of the mono pile from uncontrolled movements during the mono pile upending and lifting process on the vessel.

The upending hinge measures 6 meters (outside dimension) by 80 meters (length) and weighs 800,000 kilograms. To meet the requirements for fabrication within the allotted time frame, ISC used ProSteel to prepare the workshop drawings. Within ProSteel's 3D modeling environment, the project team achieved an innovative design that fulfilled the project requirements.

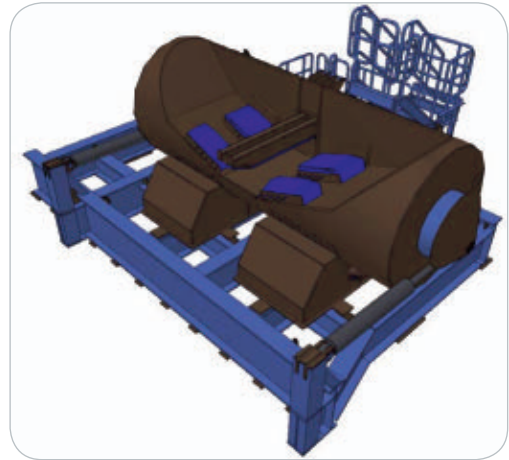

ISC Consulting Engineers A/S
Workshop Drawing With ProSteel
 Copenhagen, Denmark

ISC Consulting Engineers designed several pile grippers for use in the installation of offshore windmills in Copenhagen, Denmark. The plan was to use the pile grippers for offshore driving of steel mono piles. The purpose for the pile gripper is initially to hold the pile in a vertical position and then to maintain the pile vertically during driving by applying a horizontal force.

To meet the requirements for fabrication within the allotted time frame, ISC used ProSteel to prepare their workshop drawings. Within ProSteel's 3D modeling environment, the project team achieved an innovative design for the pile grippers that allowed for the necessary changes in the position of the piles at the offshore windmills.

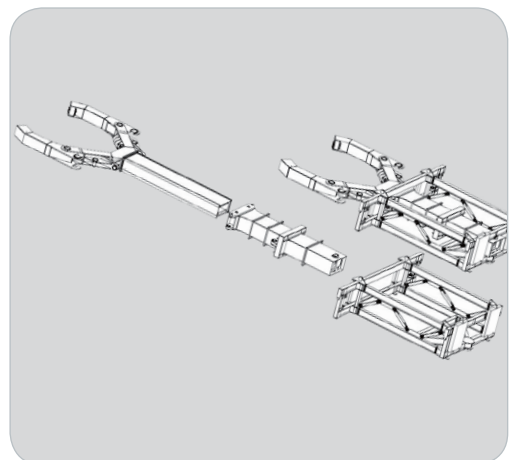
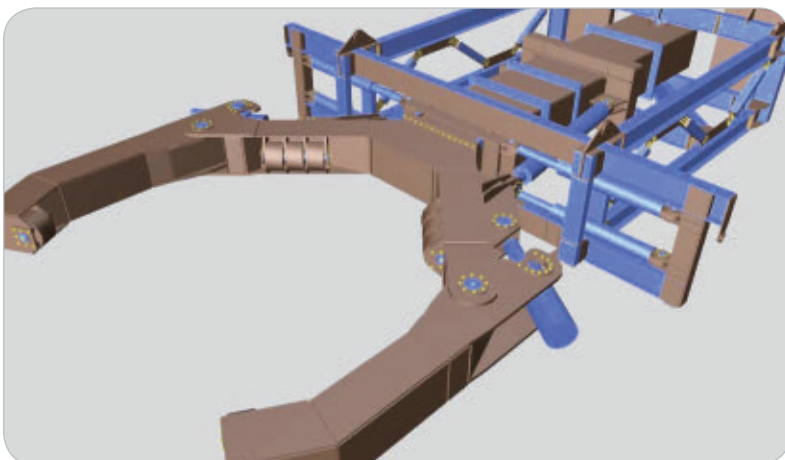

Zentech Engineering Co., Ltd.

2 Megawatt-class Offshore Wind Turbine Project

Mokpyo, South Korea

Zentech Engineering applies advanced technology to onshore and offshore engineering projects worldwide. For this project, the company designed the prototype for a 2 megawatt capacity wind turbine power plant as part of a wind power generation complex off the west coast of South Korea.

The KRW 12 billion project was the first that the company undertook using SACS software, which provided a set of tools for the design and analysis of offshore

wind turbine structures subject to wave, wind, and mechanical loading. The analysis approach is capable of predicting both fatigue and extreme loads for the substructure and non-linear foundation. Using SACS ensured that the project met the design requirements for the geographic region.

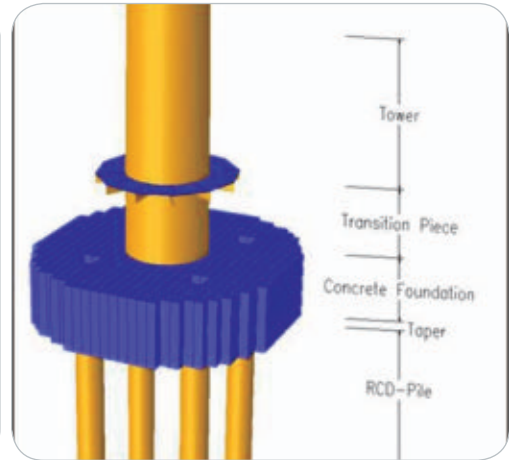

INDEX – ALPHABETICAL BY ORGANIZATION

	ORGANIZATION NAME	PROJECT NAME	PAGE
	Aker Yards ASA, Langsten	Delivering the World's Biggest and Most Advanced Seismic Vessel on Time	8
	APL	Alvheim Field Development Project	8
F	BP	Tangguh Project	9
F	CNGS Engineering	Central Process Platform – V. Filanovsky Oil Field	9
F	CNGS Engineering	Ice-resistant Offshore Platform LSP-1	10
F	CNGS Engineering	LAM-B Wellhead Platform	10
	Dar Al-Handash	New Main Brine Intake Station at Dead Sea	4
SR	F Ecofys Netherlands B.V.	Wind Turbine Test Site	34
	EDG	Chevron Offshore Platform Project	11
	Francis Design Consulting SARL	Villa 567 Cote d'Azur	30
HM	Guodian United Power Technology Co. Ltd.	SACS Application in the Offshore Wind Turbine Foundation and Substructure Design	34
	Hojuara AS-Built 3D, Ltda.	Change of Gas and Oil Fiscal Survey Equipment	11
	Hyundai Heavy Industry	BP Quad 204 Project	12
	Hyundai Heavy Industry	Shwe Gas Project	12
	Incat Crowther	Bhagwan Dryden	30
	ISC Consulting Engineers A/S	Upending Hinge Installation of Mono Piles	35
	ISC Consulting Engineers A/S	Workshop Drawing With ProSteel	35
	Kavin Engineering and Services Private Limited	FPU JOKOTOLE	13
W	KBR/EOS Oil & Gas Services Joint Venture	The North Rankin Redevelopment Project	13
	Kencana Bestwide Engineering	Front-end Engineering and Detail Design for D1 Cluster Development Project	14
	Keppel Shipyard Ltd.	Helipad on FPSO	14
	KH Engineering BV	The FPSO Mystras	15
	Knowsley SK	Offshore Production Platform Deluge Skid	15
F	L&T-Valdel Engineering Ltd.	OSX-3 FPSO Project	16
	Larsen & Toubro Limited	Assessment of Offshore Platform for Vibration Safety	16
	Larsen & Toubro Limited	GDU-GSU Module for MHN Project	17
	Larsen & Toubro Limited	NQRC – PGC Module	17
	M7 Offshore	Bergesen Worldwide Offshore – Bilabri – FPSO Upgrade	18
W	Nippon Steel & Sunikin Engineering Co., Ltd.	Tokyo International Airport Re-expansion Project	4
HM	Oil and Natural Gas Corporation Limited	HC Platform: ONGC	18
	Oil and Natural Gas Corporation Limited – IEOT	Guyed Tower Platform Concept for Marginal Fields	19
W	Petrobras SA	SGO Project – Petrobras Subsea Asset Tracking	19
W	Petrofac Brownfield	CNS Subsea Tieback and Gas Compression Module	20
	Petrofac Brownfield	Documentation Management Systems Upgrade	20
	Projemar S.A.	FPSO P-47 Conversion	21
W	PT McDermott Indonesia	Cuu Long Su Tu Vang Project	21
W	Qatar Petroleum	Creation of Intelligent As-Built Models of Offshore Facilities	22
	Quip S.A.	Offshore Platform P53	22

WINNER

W

FINALIST

F

SPECIAL RECOGNITION WINNER

SR

HONORABLE MENTION

HM

INDEX – ALPHABETICAL BY ORGANIZATION

ORGANIZATION NAME	PROJECT NAME	PAGE
Ramboll Engineering Consultancy Services India Pvt. Ltd.	Offshore Platform As-built Model	23
Ramboll Engineering Consultancy Services India Pvt. Ltd.	Small Bore Branch Support	23
Ramboll Future	SPP300 Perinema FPSO	24
Rishabh Software Pvt. Ltd.	Hebron Topside Project	24
RNZ Pegasus Asia Pacific Sdn. Bhd.	Pipeline and Riser Detailed Design Engineering	25
F Robert Elks & Associates	Rock Bolting Rig	5
F STX Shipbuilding	Virtual Tour	31
SR W TECON S.r.l.	Costa Concordia Wreck Removal Project	5
WorleyParsons Services Pty Ltd.	Victoria Platform Development	25
Zentech Engineering Co., Ltd.	2 Megawatt-class Offshore Wind Turbine Project	36
Zentech Engineering Co., Ltd.	Gumusut-Kakap Semi-FPS Project	26
Zentech Engineering Co., Ltd.	Modularization Design for Ruwais Refinery Project	26
W Zeton Inc.	Modular GTL Commercial Demonstration Plant	27





Recognizing the critical importance of being a good corporate citizen, Bentley is uncompromisingly committed to supporting ecological sustainability. This support goes beyond the stewardship of environmental resources to include investment in strategic educational and training initiatives that foster a workforce of skilled infrastructure professionals capable of meeting the world's growing sustainability challenges.

www.bentley.com

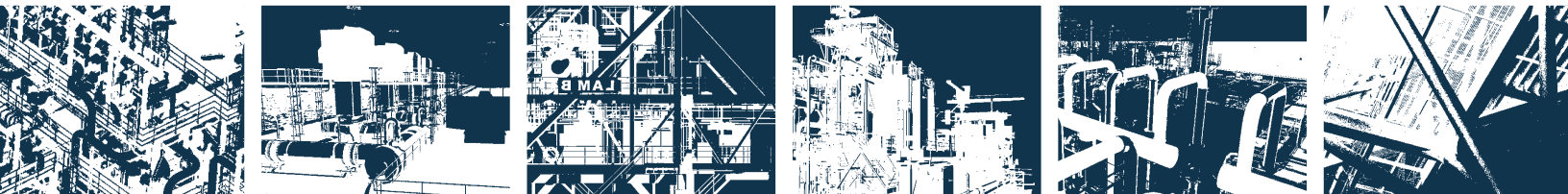

Corporate Headquarters

685 Stockton Drive • Exton, PA 19341 • United States
1-800-BENTLEY (1-800-236-8539) • Outside the United States +1 610-458-5000

Bentley EMEA

2nd Floor • Block 2, Park Place • Upper Hatch Street • Dublin 2 • Ireland • +353 1 436 4600

Bentley Asia

Unit 1402-06, Tower 1 • China Central Place, Beijing 100025 • China • +86 10 5929 7000



© 2014 Bentley Systems, Incorporated

5043 0114