

# THE PROJECTWISE PROJECT SHOWCASE

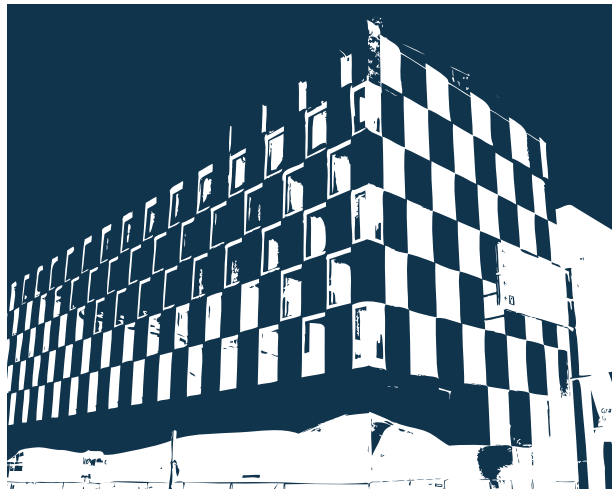

Extraordinary Infrastructure of the *Be Inspired* Awards

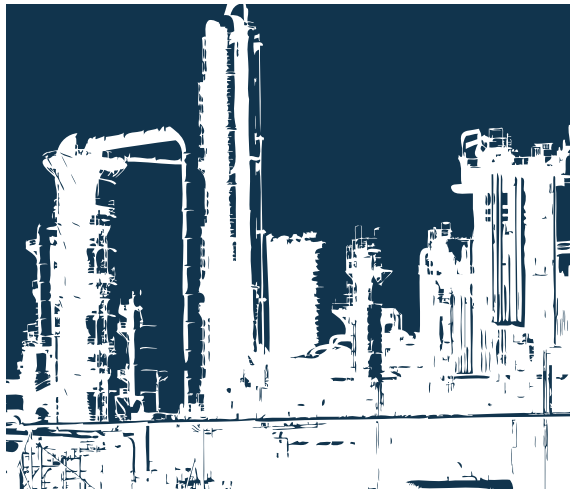

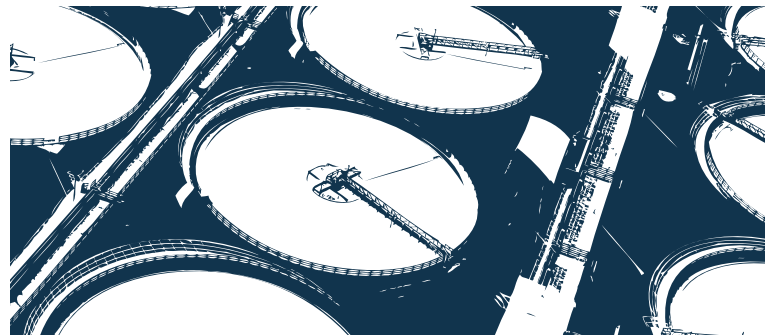
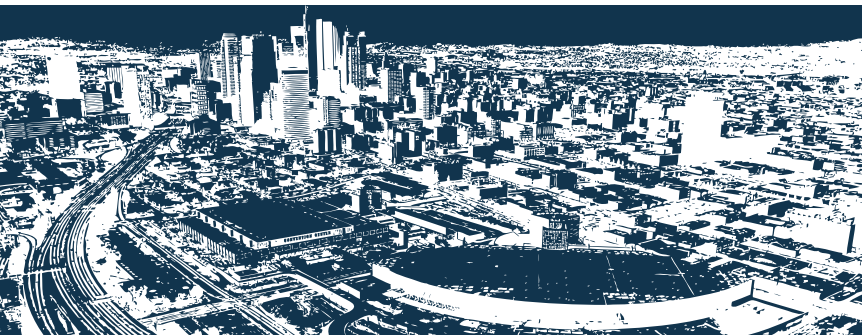
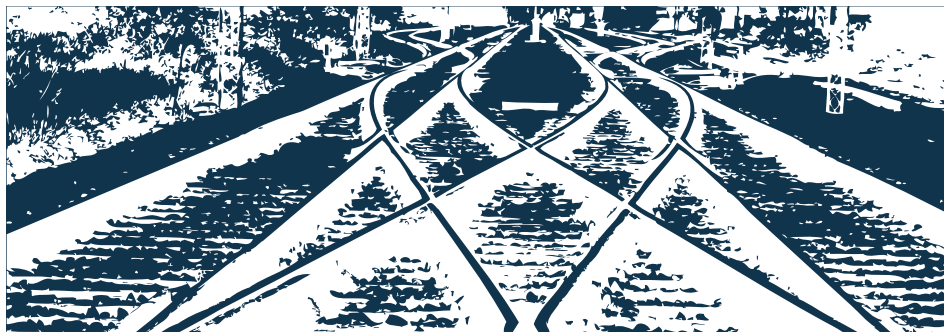

Bentley's mission is to provide innovative software and services for the enterprises and professionals who design, build and operate the world's infrastructure – sustaining the global economy and environment for improved quality of life.

*The ProjectWise Project Showcase* and *The Year in Infrastructure* series of publications are project yearbooks published by Bentley Systems, Incorporated that showcase the extraordinary work of Bentley users sustaining the world's infrastructure.

For information about how to enter your innovative project for consideration in the next *Be Inspired Awards* competition or for additional information about this program, visit [www.bentley.com/BeInspired](http://www.bentley.com/BeInspired).

#### ONLINE VERSIONS

Digital versions of the *Be Inspired Awards* publications are available online at [www.bentley.com/YearinInfrastructure](http://www.bentley.com/YearinInfrastructure). Choose to view a specific issue or search across issues using terms, titles, or keywords.

Also browse Bentley's *Be Inspired Project Portfolios* at [www.bentley.com/Projects](http://www.bentley.com/Projects), which feature the extraordinary winners and finalists in Bentley's annual *Be Inspired Awards* competition. Through these portfolios of exemplary project achievements, Bentley shares innovative best practices with the architects, engineers, constructors, geospatial professionals, and owner-operators who sustain the world's infrastructure.



Published by Bentley Systems, Incorporated  
685 Stockton Drive  
Exton, PA 19341  
[www.bentley.com](http://www.bentley.com)

# IT TAKES A TEAM TO PRODUCE GREAT INFRASTRUCTURE

The design and construction of every work of infrastructure is inherently a team effort. This team – which may include planners, engineers, architects, fabricators, detailers, constructors, subcontractors, specialty consultants, and, of course, the client – is assembled for the sole purpose of bringing a work of infrastructure from concept into operations. This project team may be distributed throughout a building, a city, a country, or across continents, and the project itself may last months or years, but for its duration, the team must engage in an intensive process of information sharing and development. In the process, ideas and designs are shared, reviewed, tested, edited, built upon, detailed, and refined continuously. This is where ProjectWise comes into play.

With its unique ability to integrate design teams that rely upon a wide range of applications in a seamless, interoperable workflow, ProjectWise provides a “single source of truth” to the project team, ensuring each member – *wherever he or she is located* – can quickly access the correct, up-to-date information needed to keep the project on track. In addition, ProjectWise’s ability to facilitate the capture and reuse of critical design information helps the team reach its ultimate goal – delivering a sustainable, high-performing infrastructure asset, a performance that is measured in terms of operational efficiency, constructability, safety, and use of energy and nonrenewable resources.

Within these pages you will find infrastructure projects that are inspirational on many levels: for the distances they span, the people they connect, the air and water they clean, and the renewable energy they produce. What they all share is that ProjectWise was used as the project team collaboration and work-sharing platform.

Each of the projects shown here in *The ProjectWise Project Showcase* has also been nominated for a *Be Inspired* award for innovation in infrastructure. They demonstrate our society’s resilience in the face of tremendous challenges, both economic and environmental, and serve as a testament to the ability of engineers and architects, geospatial professionals, contractors, and owner-operators around the globe to solve any problem, great or small.

---

# TABLE OF CONTENTS

BUILDINGS	3 – 8
CAMPUSES	9 – 11
CONNECTING PROJECT TEAMS	13 – 16
CONSTRUCTION	17 – 19
GOVERNMENT	21 – 24
MINING AND METALS	25 – 28
OFFSHORE	29 – 31
OIL AND GAS	33 – 36
POWER GENERATION	37 – 41
PROCESS MANUFACTURING	43 – 48
RAIL AND TRANSIT	49 – 54
ROADS	55 – 64
UTILITY TRANSMISSION AND DISTRIBUTION NETWORKS	65 – 71
WATER AND WASTEWATER	73 – 77
<b>INDEX</b>	
ALPHABETICAL BY ORGANIZATION	78 – 80



# BUILDINGS

Advanced technology aids in the delivery of high-quality buildings in terms of aesthetics, adherence to program, and meeting budget. It is also increasingly critical in areas of environmental sustainability, operational performance, and compliance with regulations and accreditations. Moreover, today's buildings must provide a clear return on investment. The projects in this category demonstrate excellence in designing, building, or operating one or more buildings.

# BUILDINGS

Al Futtaim Carillion

## MotorCity Uptown Area II Buildings

Dubai, United Arab Emirates

Dubai's uptown MotorCity is a master-planned neighborhood with amenities, schools, recreation areas, sports facilities, and retail outlets. Within the first month of construction in Area II, Al Futtaim Carillion implemented enterprise-level engineering content management to make information readily accessible to the in-house team and external contractors on three continents. ProjectWise proved to be 80 percent more efficient than a paper-based system.

More than 7,000 design drawings were imported into ProjectWise and in excess of 300,000 records were managed for this USD 490 million project. During deployment, the entire team used the collaboration tools to work efficiently across time zones. Training by Bentley and Al Futtaim Carillion's ProjectWise power users familiarized contractors with the system, which saved time in finding and distributing information.



Barclays Bank PLC

## Space and Asset Data Capture

London, United Kingdom

To manage its U.K. retail branch network of 1,634 properties, Barclays needed to accurately capture and record space and asset data, and then make this data available to decision makers at the branches to relay to high-level management. The solution was to develop a "Branch on a Page" web-based dashboard that provided fast and efficient access to critical business data for individual properties.

ProjectWise was the collaboration tool used to connect Barclays' in-house design and delivery teams with contractors working on the project. Bentley software also allowed Barclays to bring in-house externally maintained databases at a cost savings of USD 800,000 per year. By migrating branch activity planning resources into the Bentley system, Barclays was able to analyze activity across the entire network, resulting in cost savings of USD 500,000 per year.

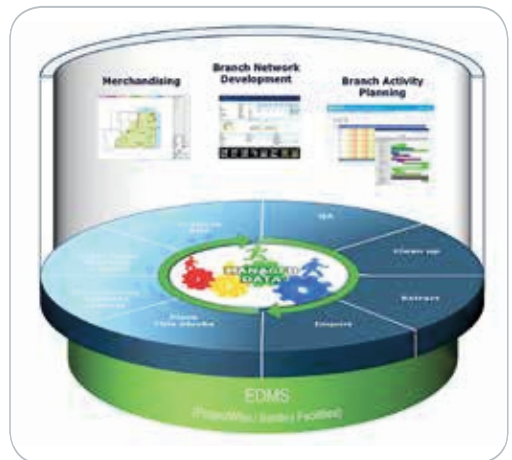
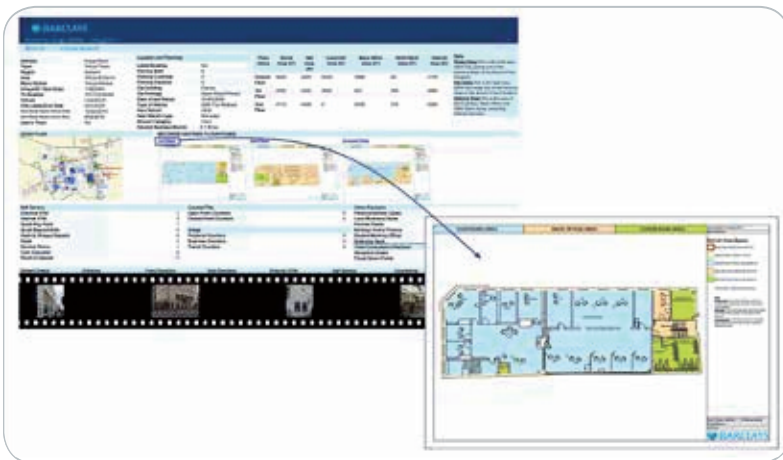

Dillard's

Dillard's Store Planning Application

Little Rock, Arkansas, United States

Headquartered in Little Rock, Ark., Dillard's department stores developed the Store Planning Interior Design Application to streamline the store design process. The task-based tools enable store planners to place department-specific fixtures throughout the approximately 300 stores. Dillard's created the custom application using Bentley Architecture and ProjectWise.

Bentley Architecture provides the framework for the customized workflow and ProjectWise captures and manages all drawings as the design information is created. Store planners access the required fixture components from cell catalogs and use specialized tools to parametrically place fixtures in the store models. The application automates the generation of interior elevations and placement of the elevations on construction documents.

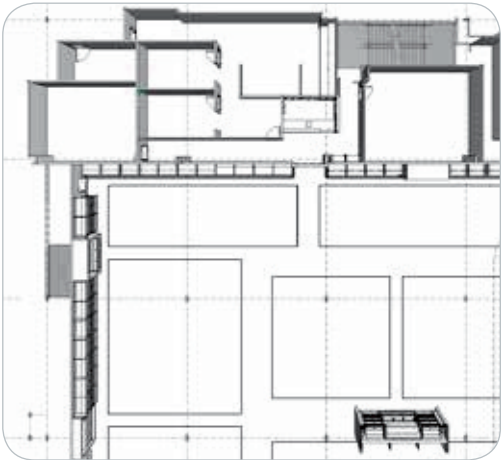
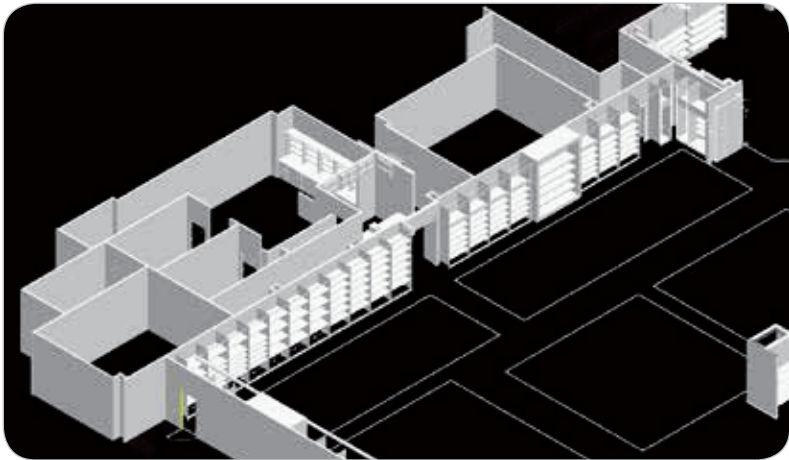

DP Architects Pte Ltd

ProjectWise Distributed Design Management

Singapore

DP Architects has offices in Malaysia, Indonesia, India, China, Thailand, and United Arab Emirates. Once ProjectWise was in place, the architects in Singapore were able to farm out production work to regional offices that had spare manpower resources and were able to check on the progress of production work in real time.

Better control over the quality of work in regional offices could be exerted from the head office, and design data and best practices could be shared. The reduction in travel costs for one project amounted to more than USD 50,000. The total savings for the firm for projects that used the system amount to around USD 500,000 each year.





# BUILDINGS

DPR Construction

## UCSF Medical Center

San Francisco, California, United States

The University of California, San Francisco (UCSF), brought together DPR Construction and key trade contractors to collaborate during design development for the USD 1.5 billion UCSF Medical Center at Mission Bay, a six-story, 289-bed specialty hospital in San Francisco. The project implemented virtual building processes to produce coordinated documents, and minimize construction costs and schedule impacts.

One goal was to meet milestones by resolving 80 percent of issues within four hours. ProjectWise helped meet this goal by streamlining information exchange and automating workflows to improve performance among the more than 350 unique users. Compared to an FTP site, ProjectWise saved USD 35,000 per design coordination area by reducing time spent managing updates. Similarly, managing reference models took 5 percent less time and sharing clash models saved USD 65,000.



GHAFARI Associates, LLC

## Sutter Health Eden Medical Center

Castro Valley, California, United States

Sutter Health's Eden Medical Center is a USD 400 million campus in Castro Valley, Calif., with a 130-bed acute-care hospital and an attached four-story clinic and radiology center. An integrated project delivery team is responsible for the interior tenant build-out. GHAFARI Associates customized a ProjectWise deployment to support the project's document-sharing needs and improve overall team collaboration.

The firm hosted the integration server at its headquarters and strategically deployed file storage and caching servers near teams doing the work. All 3D models, 2D CAD files, specifications, and other project documents were stored on the system. The use of ProjectWise saved the equivalent of a full-time document manager for four years, equating to approximately USD 1 million in cost savings. MicroStation and Bentley Navigator were also used in the project.

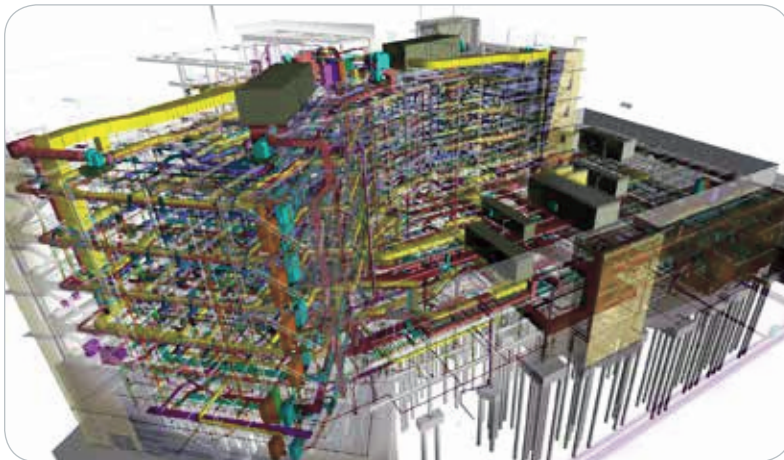

Moh and Associates, Inc.  
**Collaboration and Integration of ProjectWise**  
 New Taipei City, Taiwan

The challenging design of the USD 50 million Metro Rail Transit station under development in New Taipei City, Taiwan, prompted the project team to introduce building information modeling (BIM) into the design phase. BIM models built using Autodesk Revit were integrated by converting them into compatible Bentley i-model formats, which streamlined document management, file synchronization, and version control.

Moh and Associates implemented ProjectWise to enable efficient collaboration and integration among design disciplines. All project information was classified, stored, and shared through ProjectWise. Efficient model and version control, as well as change management in associated models, contributed to better cost control and construction quality. Improved performance saved 15 percent in man-hours for an annual savings of approximately USD 250,000.



Ona Arquitectes  
**Continuum Project**  
 Barcelona, Spain

Initiated by five companies in the construction industry, the Continuum Project in Spain aims to transform the way projects are built. The unconventional approach engages interdisciplinary teams that include developers, engineers, construction companies, and contractors. This collaborative model allows the team to optimize project parameters and eliminate uncertainty while meeting customers' needs.

Bentley Architecture and ProjectWise were chosen as the platforms for data-based building information modeling, which enables management of the building both as a whole and as individual parts. The 3D visualization allows the team to focus on details, sections, and assembly processes, and the team can generate cost, schedule, and logistics specifications during drafting, which saves time and avoids activities that are inconsistent with the model.

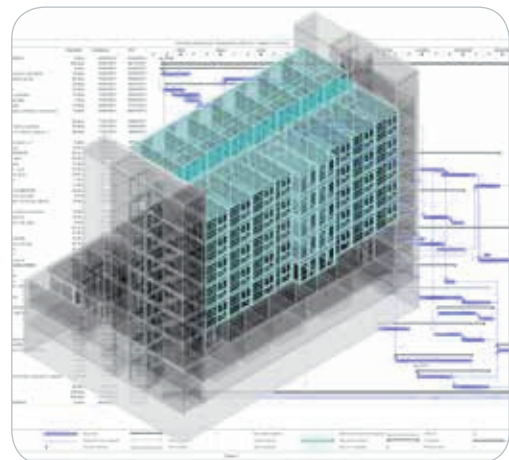

# BUILDINGS

Volkswagen of Brasil

## New Painting Building Facility

Sao Paulo, Brazil

Volkswagen of Brazil is building a USD 638 million facility for painting 1,300 cars per day at the Taubate plant. The first project of its size in Brazil to be fully modeled in 3D, the building was designed in Germany using Bentley Architecture and the process line was designed in Brazil. ProjectWise allowed team members in both countries to collaborate and detect possible clashes.

All drawings and documents received from Germany were deposited in ProjectWise so Volkswagen could check for interferences and make adjustments. Hundreds of interferences have been detected in the building and process line, saving an estimated USD 20 million in rework and delays. The software facilitated decision making, which reduced project execution and delivery time by 10 percent.

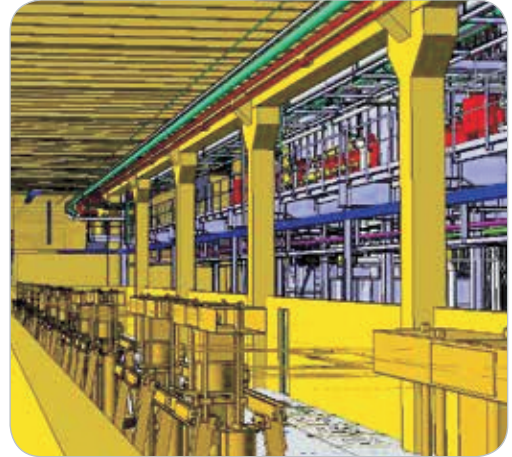



# CAMPUSES

This category celebrates innovative approaches to design, construction, and operation of all types of campuses, airports, and military installations. Managing a facility's spaces, assets, and occupancy requires information created in many systems by many people over time. A digital asset facilitates design collaboration, supports construction delivery, and leverages facility information for operations and maintenance.

# CAMPUSES

## CH2M HILL

### Phase 1—O’Hare Modernization Program

Chicago, Illinois, United States

The USD 3.3 billion Phase 1 modernization program at Chicago’s O’Hare International Airport called for construction of the first new runway (9L/27R) since 1971, extension of an existing runway (10/28), and a new north airfield air traffic control tower (NATCT). The program required relocation of a railroad, creek, airport guard post, lighting control vaults, and high-pressure water main.

Design began simultaneously on all major and enabling projects, before phasing and constructability were completed. This precipitated the transfer of portions of design packages to other design teams while maintaining delivery dates. The project involved 600-plus people working in more than 30 offices. ProjectWise housed more than 100,000 MicroStation design files in a central location, with portions being exported to major design team locations.



2009 *BE INSPIRED* AWARD WINNER

## Oakridge National Laboratory – Facilities Development Division

### Sustainability in Information Management Through CIM

Oak Ridge, Tennessee, United States

The U.S. Department of Energy’s Oak Ridge National Laboratory (ORNL) is a multiprogram science and technology laboratory. With complex engineering information dating back to the Manhattan Project, ORNL improved accessibility, reliability, and sustainability of information management as part of a USD 500 million modernization effort that integrated new and legacy information into one location.

Based on ProjectWise’s geospatial capabilities, the system allows management of MicroStation, Bentley Map, Bentley i-models, and other data. Multiple users search for and retrieve documents through a map interface and integrate various data formats to query metadata. Bentley Geo Web Publisher provides a portal for integrating and viewing select information. ProjectWise automatically distributes updated information.

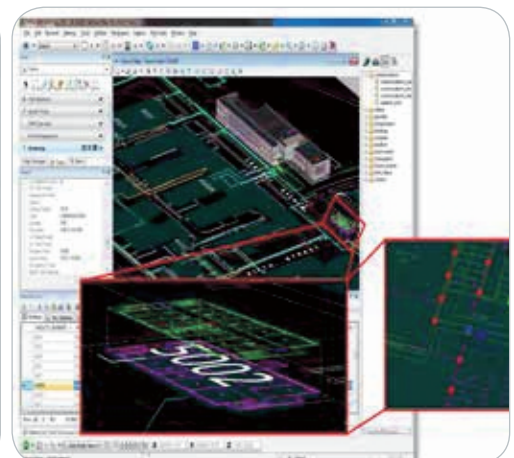
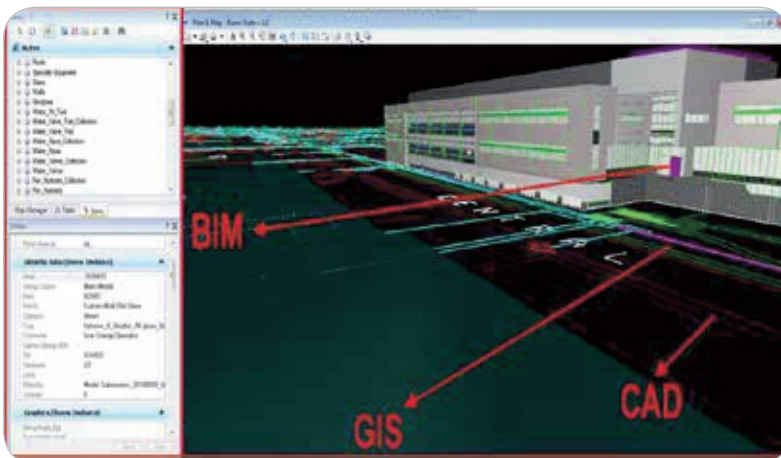

2011 *BE INSPIRED* AWARD FINALIST

Sydney Airport Corporation Limited

## Enterprise Engineering Document Management Project

Sydney, Australia

Currently in the implementation phase, this project will link the strategic and planning elements of Sydney Airport's master plan to its infrastructure requirements, including property development, retail management, maintenance, financials, landside and airside improvements, and space management of airport facilities. These infrastructure requirements are managed by airport staff for enterprise use and are linked to the day-to-day operation of the airport.

The Sydney Airport uses ProjectWise and MicroStation to centralize and link master document formats with managed document records while allowing controlled edit access to a single master source. The engineering document management system provides a more efficient, scalable, and reliable management environment that allows Sydney Airport's 450 infrastructure and engineering professionals to access asset and project information without relying on Airport Design Services.

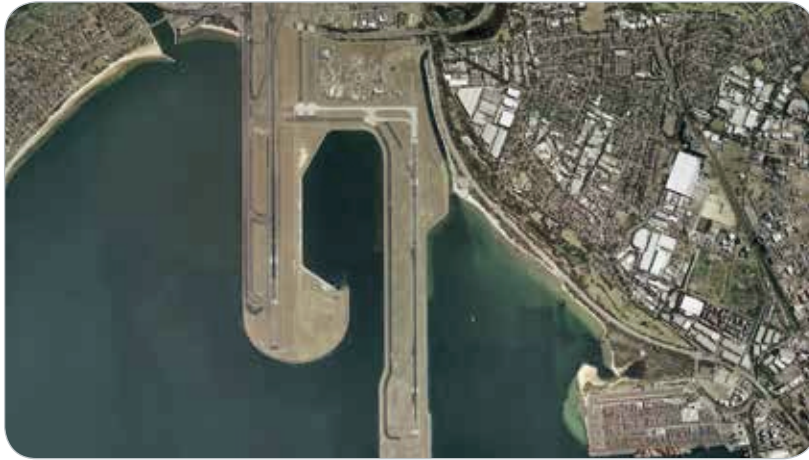

U.S. Army Garrison Bamberg

## ProjectWise and MicroStation Deployment

Bamberg, Germany

The U.S. Army Garrison in Bamberg, Germany, consists of approximately 6 million square feet of combined housing, industrial, and office space; 3,300 acres of land and supporting infrastructure; 20 miles of roadway; and an airfield, railroad, golf course, and forestland that supports a community of approximately 10,000. The project goal was to create an accessible, expandable, and stable document file system to support the work processes of the Directorate of Public Works.

This file system establishes a common platform to access drawing and project-related information through an intuitive graphical user interface. ProjectWise, MicroStation, and Bentley Geospatial Server were used to create the new file structure. The system's geo-referencing search capabilities gives users immediate access to drawings, which involves the workforce more actively in the engineering process.

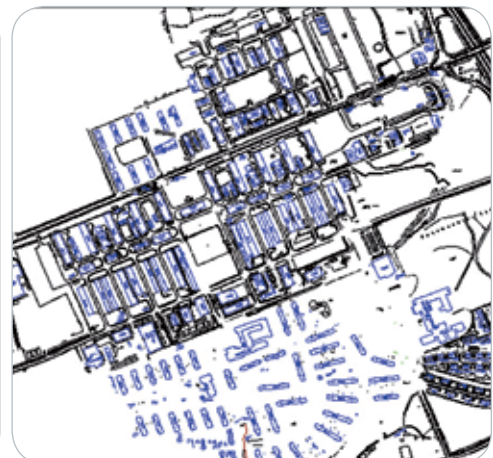



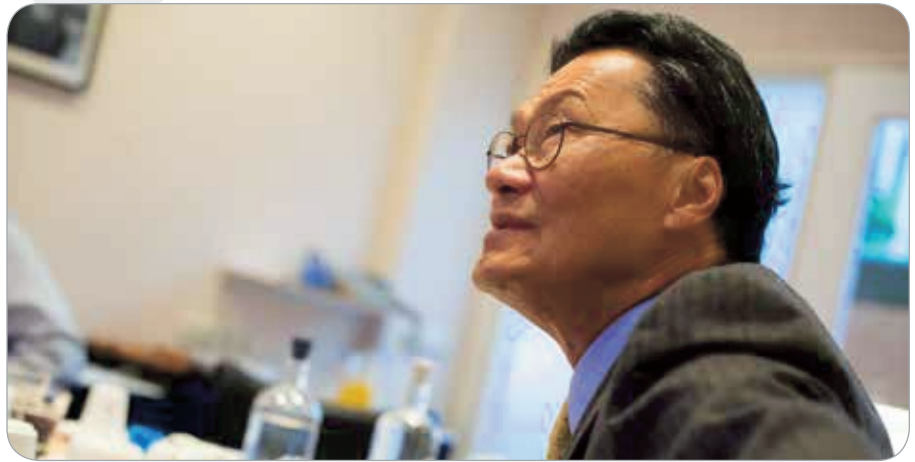

# CONNECTING PROJECT TEAMS

There is an increasing need among infrastructure organizations to connect people and secure critical project information. The projects in this category demonstrate success in connecting widely distributed project teams for dynamic collaboration and work sharing to improve project performance.

# CONNECTING PROJECT TEAMS

China Huanqiu Contracting & Engineering Corp.

## Establishing a Collaborative Content Management Platform

Beijing, China

China Huanqiu Contracting & Engineering has five subsidiaries throughout China with more than 1,000 employees. The company had multiple systems for project management in 2D and 3D design, which made it difficult to share and exchange engineering information among systems. To more accurately and efficiently manage engineering content during the entire lifecycle of projects, the company deployed ProjectWise.

Design teams from different locations were connected using ProjectWise's distributed functions, enabling team members to access the latest versions of project files. The ProjectWise collaboration system allows teams to customize sets of attributes suitable for different projects and to expand functionality to meet specific needs. With ProjectWise, engineers save 30 percent in man-hours due to efficient information sharing and searching.

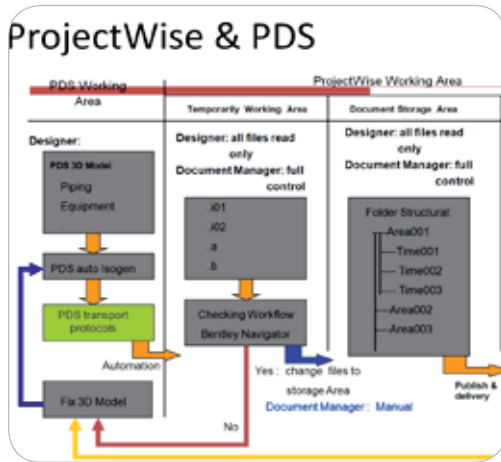

DPR Construction

## ProjectWise Implementation

San Francisco, California, United States

As the document manager relaying information between designers and specialty contractors, DPR Construction is responsible for communicating the latest information to all teams. DPR's USD 500,000 ProjectWise implementation has been the document-sharing platform for 41 projects with a combined net value of more than USD 2.5 billion since 2009, facilitating efficient collaboration by unifying team members in multiple companies at different geographic locations across 10 regions.

ProjectWise has streamlined information exchange and improved performance among team members by automating the workflow. San Francisco, Calif.-based DPR Construction has a ProjectWise network that currently has 1,300 users in 300 companies. As more companies join the DPR network, ProjectWise deployment on new projects becomes quicker, and conversations that can save money and time are more direct and transparent.

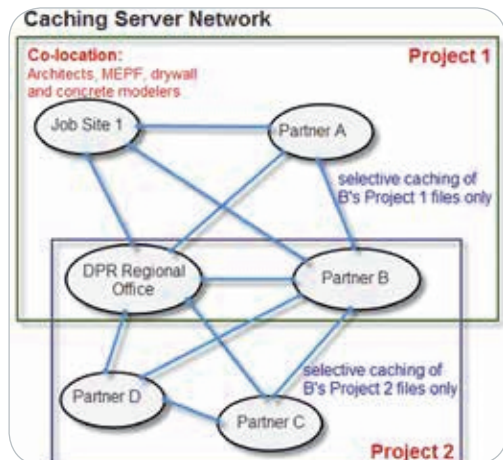
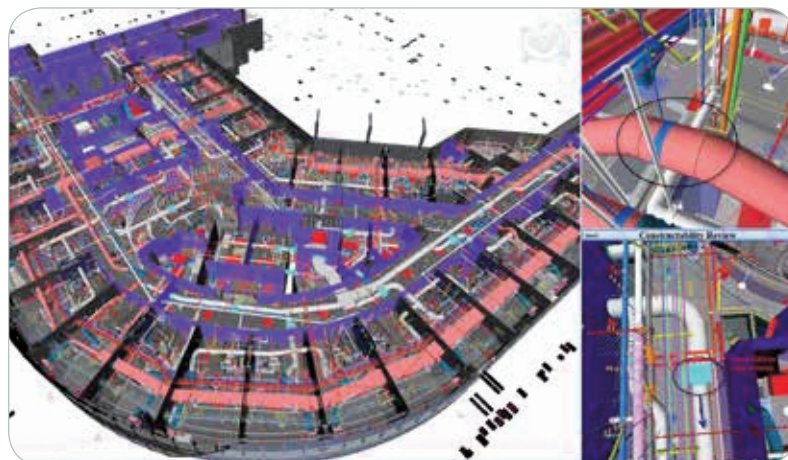



# CONNECTING PROJECT TEAMS

Guangdong Highway Design Institute Co., Ltd.  
**ProjectWise Application in Humen Project**  
Guangzhou, China

In Guangdong, China, the Humen No. 2 bridge spans an island and two waterways to connect the towns of Dongyong and Shatian on the east and west banks of the Pearl River. The USD 1.8 billion viaduct is 20.92 kilometers long and is comprised of two suspension bridges. With various departments and sectors involved, the vigorous engineering information management requirements on this project made traditional workflows obsolete.

The Institute integrated the management information system with the ProjectWise collaboration system to achieve resource sharing, uniform workflows, and electronic archiving. Duplicate data entry was eliminated using ProjectWise Dynamic Plot for digital management of drawing reviews and modifications. Synchronization between systems has improved work efficiency on various project information management tasks by up to 50 percent.

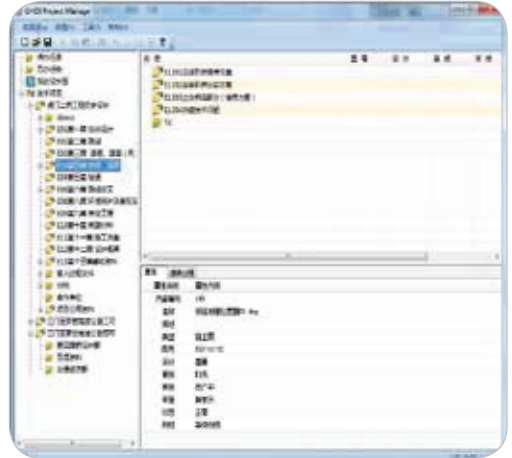

Mott MacDonald Limited

## How ProjectWise Is Providing Global Collaboration as an Enterprise Solution

London, United Kingdom

Mott MacDonald is a multidisciplinary company working on projects across 12 sectors. Drawing skilled team members from 300+ offices enables the company to tackle projects in more than 120 countries. ProjectWise enhances Mott MacDonald's ability to bring together the right mix of expertise and experience. Embedded in the company's global project information management system, ProjectWise helps manage engineering data across the enterprise.

As a result, building information modeling experts in the United Kingdom and North America participate in global projects such as the GBP 700 million redevelopment of Bank Station in London's commercial district; the GBP 3.86 billion development of the four-tower, 70-story Dubai Pearl in United Arab Emirates; and the GBP 226 million expansion and modernization of Male International Airport in Maldives.

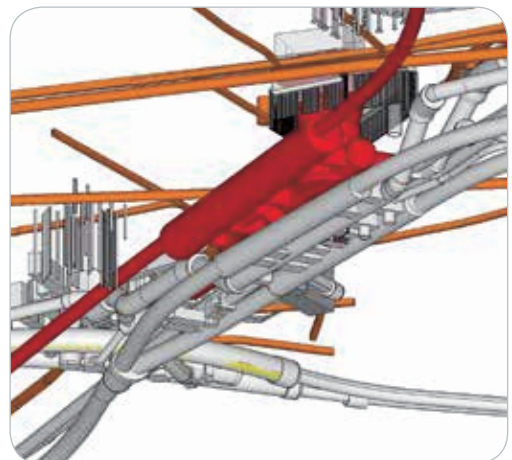
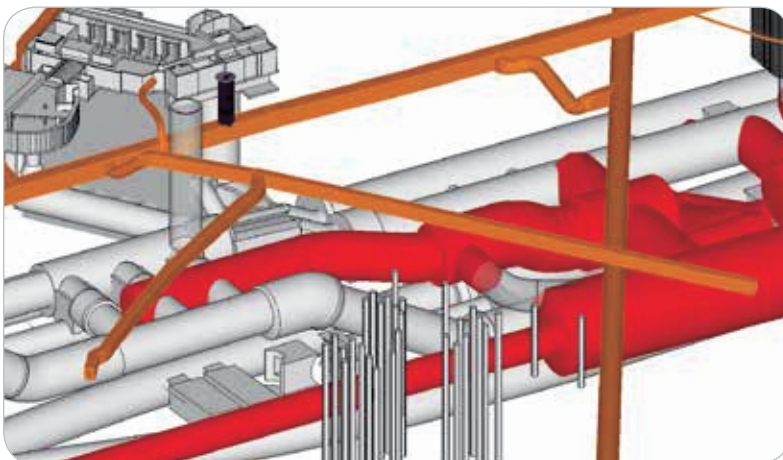

# CONNECTING PROJECT TEAMS

Parsons Brinckerhoff

## ProjectWise Automated PDF Generator

Norfolk, Virginia, United States

The design-build team for the USD 4 billion Midtown Tunnel project in Norfolk, Va., needed to allow reviewers and task leaders across multiple companies and offices to view PDFs depicting design progress. Team members also needed to produce PDFs that conform to correct plot criteria and standards. Parsons Brinckerhoff built an automated PDF generator that uses real-time DGN files to create the PDFs every night.

The ProjectWise Automated PDF Generator takes under two minutes to create a PDF from an updated contract document and place it in a controlled-access output folder in the ProjectWise directory. Team members can also use the generator to create PDFs on demand. The PDF generator allows task leaders to track work side by side with other disciplines, narrowing the gap between design and review.

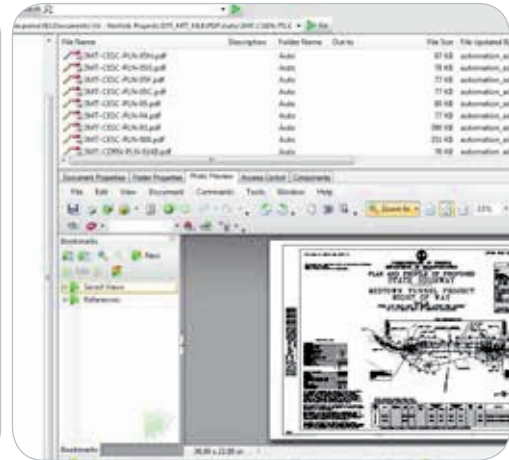
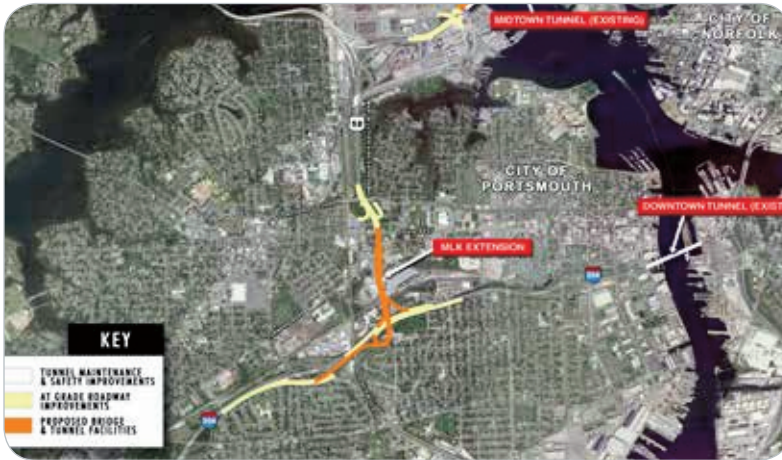

SNC-Lavalin Australia Pty Ltd.

## Visualization: A Leap of Faith

Brisbane, Australia

SNC-Lavalin's Australian business unit was an early adopter of Bentley Navigator, and integration within the MicroStation environment was achieved using ProjectWise distribution services to extract models, using simple batch files to automate scheduled model creation, and managing overlay files in ProjectWise.

Bentley Navigator ensures a stable, intelligent, and detailed review model to present to project teams and the client's engineering staff. Reviewers provide feedback via mark-ups, and engineers provide direct 3D input into the design process. Model load times are reduced by up to 80 percent, with model sizes reduced by up to 60 percent, and clashes are resolved sooner.



# CONSTRUCTION

Projects in this category exemplify overall excellence during the construction phase of a project. They demonstrate a clear return on investment via shortened project schedules, mitigated risks to avoid overruns, and the application of technology for advanced work processes within the construction workforce to benefit all stakeholders.



# CONSTRUCTION

DPR Construction

## Arizona State University New Business School

Tempe, Arizona, United States

DPR Construction developed a lean modeling approach to delivering 3D visualizations on site during construction of Arizona State University's new USD 60 million business school in Tempe. The goal for this project was to generate real-time virtual mock-ups from federated models to pave the way for 3D rolling completion lists and punch list mark-up items.

The integrated platform of Bentley Navigator, AECOsim Building Designer, MicroStation, and ProjectWise generated and packaged sequential building information models (BIMs) for field validation. The process eliminated reproduction of drawings/spool sheets from the model, which reduced field BIM labor time by 12 to 14 percent. Based on initial metrics, the labor reduction translated into a 35 percent cost savings on BIM resources during construction.

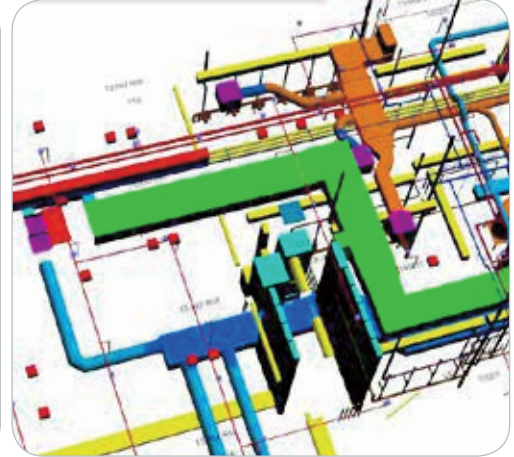
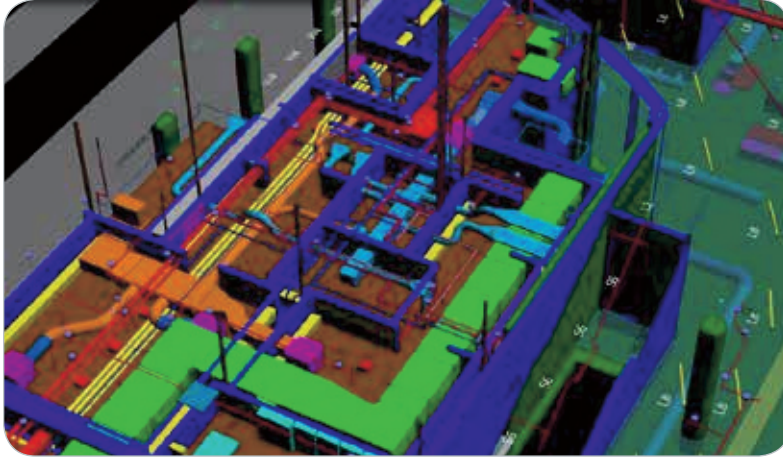

HNTB Corporation

## Firm-wide Design-build Quality Plan

Alexandria, Virginia, United States

HNTB's TrueViz Q-Assist program develops protocols to align quality procedures with the aggressive schedules and 3D deliverables associated with alternative delivery projects. These procedures make data from multiple sources available for review by staff at multiple locations and capture results in a managed environment. HNTB standardized this process on integrated software.

HNTB uses MicroStation to display data from all applications; ProjectWise as the central data store; Bentley Navigator for mark-up checking and conflict resolution; ProjectWise to capture mark-ups in a managed environment; and Bentley Navigator for 4D construction phasing. A pilot test during Virginia Department of Transportation's USD 600 million 95 Express Lanes project detected more than 500 potential conflicts on the first run, saving about USD 100,000 on a single resolution.

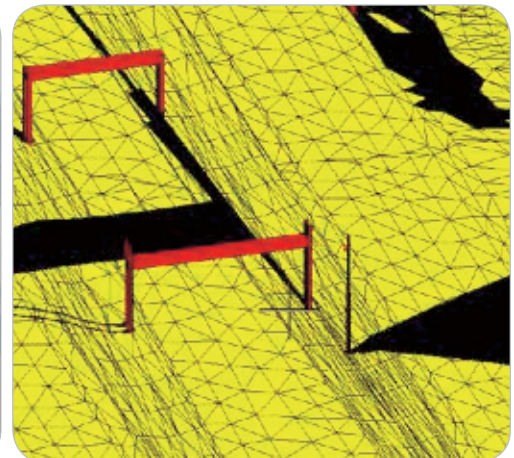

2012 BE INSPIRED AWARD FINALIST

## Four Major Rivers Restoration Project

Gyeonsangnam-do, South Korea

This USD 3.8 billion restoration initiative in the Nakdong River area of South Korea is a highly visible infrastructure construction project. Bentley Navigator provided the tools to simulate construction activities and plan the schedule, which provided a web-based construction schedule management system that allowed the client to review the process from remote locations.

Using Bentley Navigator enabled IDM to precisely and rapidly build a 3D model that communicated the construction plan to the local community. The system helped to control costs and reduce construction time, which will contribute to delivering the project ahead of schedule so that the infrastructure can begin to benefit the local economy.

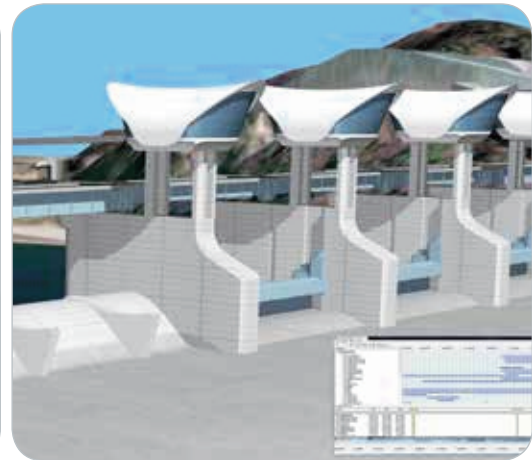
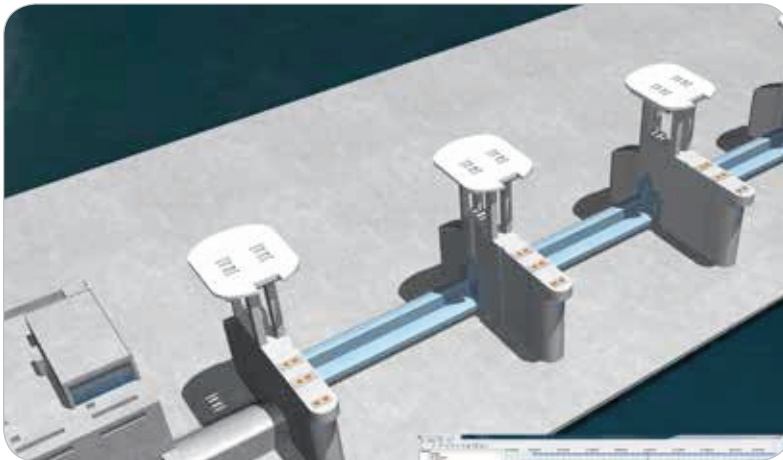

## Shawmut Design and Construction

### Dudley Square Municipal Building

Boston, Massachusetts, United States

Located in Boston's Roxbury neighborhood, the USD 86 million Dudley Square Municipal Building will occupy the site of the historic Ferdinand Building in Massachusetts. The urban location posed significant challenges, including preservation of three historic facades, coordination among two architectural design teams and dozens of subcontractors, and six construction-document release packages.

Shawmut Design and Construction's design methodology allowed the construction management team to collaborate closely with the design team on resolving constructability issues in real time. This reduced rework and kept the project on the shortest path to delivery. The firm used ProjectWise to collaborate, ProjectWise Clash Resolution to review components within the model, and Bentley Navigator to review models.

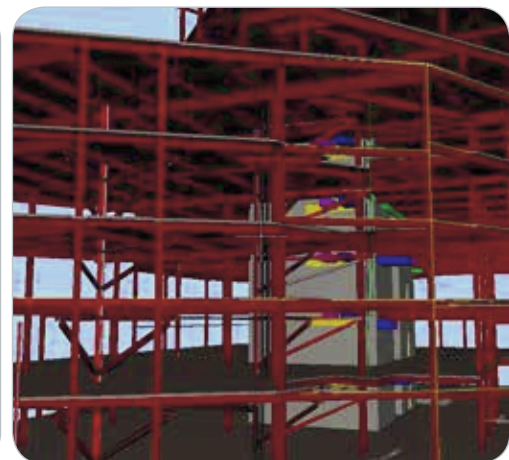

2012 *BE INSPIRED* AWARD FINALIST







# GOVERNMENT

The submissions in this category have demonstrated excellence in local, state, provincial, federal, and national government projects. These projects leverage engineering content and team collaboration, geospatial, civil engineering, and communications network technology, or combinations thereof. They also use innovative and cost-effective techniques to manage land parcels, create cadastral fabric, analyze land uses, and execute land and site development projects.

# GOVERNMENT

Crossrail Limited

## Crossrail

London, United Kingdom

Crossrail is a cross-London rail link being developed to serve London and southeast England. The USD 24.5 billion project will address London's heavy traffic congestion, providing modern trains to bring an additional 1.5 million people within a 60-minute commute of key financial and leisure centers. The project includes twin-bore 21-kilometer tunnels under central London with interchanges to the existing rail network.

To overcome the size and complexity of the project, Crossrail's integrated project team standardized on Bentley products. All of these software applications share a common software platform and contribute to a fully coordinated 3D model. The distributed project team is connected across multiple locations by ProjectWise to deliver time and cost savings. Currently there are more than 1,300 ProjectWise users involved in the project.

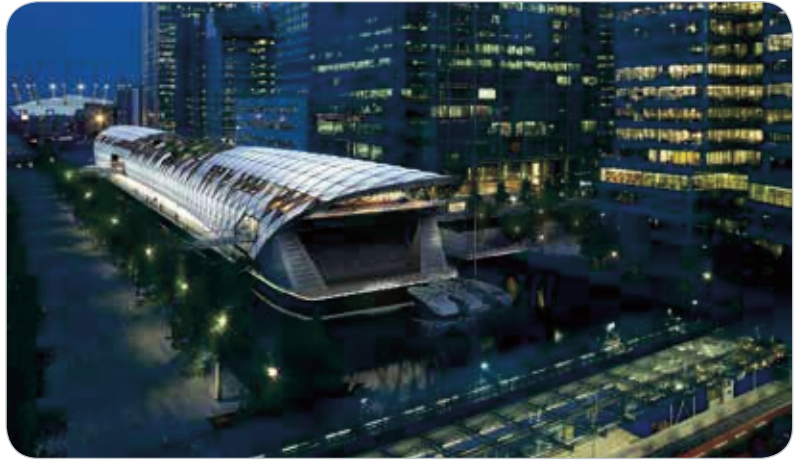

2010 *BE INSPIRED* AWARD WINNER

Maryland State Highway Administration

## 2011-2012 Maryland Official Highway Map

Baltimore, Maryland, United States

The 2011-2012 edition of the Maryland Official Highway Map commemorates the War of 1812 and bicentennial activities. Updated biannually by the Maryland State Highway Administration, the map features approximately 1,100 geographic places, 159 incorporated municipalities, interstate routes, highways, natural parks, airports, colleges, and universities. The special edition added War of 1812 battlegrounds, historic sites, and tourist attractions.

The state saves time and taxpayer dollars on updates by using MicroStation to design the map and CADscript for post-processing using the what-you-see-is-what-you-get interface. The project team simply creates a new directory folder and copies the design files to be edited for the next edition. The project team uses ProjectWise to acquire up-to-date design information from multiple locations throughout the state.

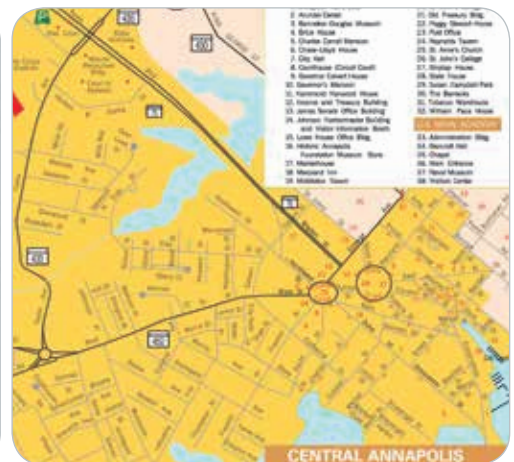

Port of Helsinki

## Vuosaari Harbour Maintenance System

Helsinki, Finland

The new Vuosaari cargo harbor complex in Helsinki, Finland, is comprised of the main harbor, adjacent business, traffic infrastructure, and logistics zone and gate area. The Port of Helsinki initiated a project to combine information about all the harbor facilities in one map-based maintenance system. The system provides access to documents, maintenance schedules, and maintenance histories for about 80 structures, buildings, and systems.

In cooperation with Buildercom, Bentley developed the integrated solution using Bentley Map for drawing maps, ProjectWise Integration Server for content management, Geo Web Publisher for the map interface, and Buildercom's FacilityInfo for maintenance information. The USD 700,000 project was completed within 1.5 years and the maintenance system now manages approximately 11,500 documents for 70 users.



2011 *BE INSPIRED* AWARD WINNER

Tetra Tech, Inc.

## Elliott Bay Seawall Project

Seattle, Washington, United States

The 70-year-old Elliott Bay Seawall along the Seattle waterfront could fail during a moderate to large earthquake. The City of Seattle engaged an array of stakeholders to participate in the USD 290 million replacement project, including restoration of the surrounding urban infrastructure. The project required effective communication with agencies, residents, and businesses as well as coordination among engineering disciplines in multiple city departments and 18 consulting firms.

ProjectWise provided a centralized environment for compiling and sharing project data, allowing the design and permitting team to quickly respond to requests and directions. The ability to integrate with multiple CAD platforms enabled the team to easily incorporate the Seattle Department of Transportation's AutoCAD-based standards and requirements. The team leveraged ProjectWise tools to encourage user autonomy, minimize IT intervention, and raise file visibility.

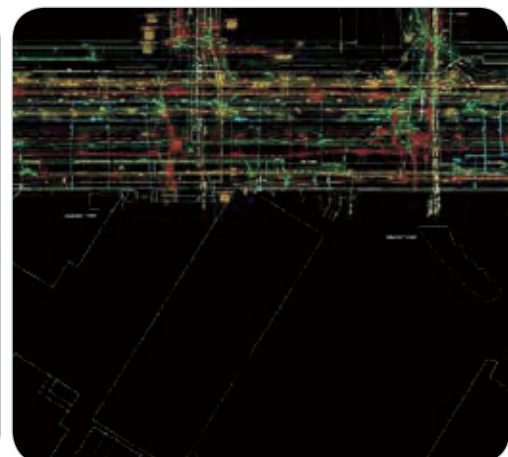



# GOVERNMENT

USACE Portland District

## Cougar Dam and Reservoir Adult Fish Collection Facility

Blue River, Oregon, United States

Located on the South Fork of the McKenzie River near Blue River, Ore., the Cougar Adult Fish Collection Facility will assist in a collecting, sorting, and transporting program to connect fish populations located upstream and downstream of Cougar Dam. The USD 14.7 million facility includes a fish ladder, pre-sort pool, sorting facility, and two pump structures for water supply.

MicroStation, ProjectWise, and STAAD enabled a shared model approach that allowed for structural, mechanical, electrical, hydraulic, civil, and geotechnical engineers to effectively integrate the design. Challenges were addressed by fostering collaboration among the design team members to maximize product reviews and ensure effective communication.



2009 *BE INSPIRED* AWARD FINALIST

Ville de Grenoble

## ProjectWise Interoperable Real Estate Municipal Database

Grenoble, France

With management oversight of more than 120,000 documents and 750 municipal buildings, a priority for the municipality of Grenoble, France, is to optimize the management of municipal real estate. The goal of this project was to federate and exploit heterogeneous data from an Oracle real estate database, GIS, CAD software (DGN and DWG), and Bentley Map. The challenge was to offer a user-friendly solution without redundancy.

MicroStation, ProjectWise, and Bentley Map provided a complete integration of the city's information system, which also acts as an experimental laboratory for implementing ProjectWise and Bentley Map in other cities. The system integrates a design team distributed over multiple locations, facilitates rapid deployment of a project team, and accelerates information sharing and communications across project teams.



# MINING AND METALS

Mining and metals engineering professionals strive to shorten project schedules and lower operating costs through improved access to mission-critical information. The projects in this category use software to demonstrate both short-term and long-term benefits that not only improve the performance of engineering and construction capital projects, but also increase the efficiency of operations for mines and metals processing and refining plants.

# MINING AND METALS

Anglo American plc

## Geospatial Integration Project

Johannesburg, South Africa

As one of the world's largest mining companies, Anglo American operates in Africa, Asia, Australia, North America, and South America. To realize its vision for fully automated and remote mining operations, the company needed to exploit 3D spatial information. The Geospatial Integration Project was designed to build an integrated GIS platform based on a common architecture to provide a single management system for geospatial data, workflows, and reports.

The ZAR 450,000 project utilizes ProjectWise, Bentley Geospatial Server, Bentley Geo Web Publisher, Bentley Descartes, Bentley Map, and MicroStation. The technology provides caching servers, delta transfer, standards enforcement, and full audit trails that ensure data integrity and change control. Currently exceeding 15 terabytes, the managed data store informs decisions regarding mine planning, design, safety, and the environment.



Aurecon Hatch

## Collaboration Using Bentley Navigator

Hay Point, Australia

BHP Billiton Mitsubishi Alliance is expanding its coal mining operations in the northern section of the Bowen Basin in Queensland, Australia. The capacity of the Hay Point Coal Terminal will increase from 44 to 55 metric tons per year in a first-phase expansion. A potential second stage would increase capacity from 55 to 75 metric tons per year.

BHP Billiton Mitsubishi Alliance, Bechtel, and Aurecon Hatch collaboratively completed the project definition using Bentley Navigator. Work hours were reduced by approximately 25 percent compared to the hours required to produce traditional drawings, and engineer training time was reduced by 50 percent.

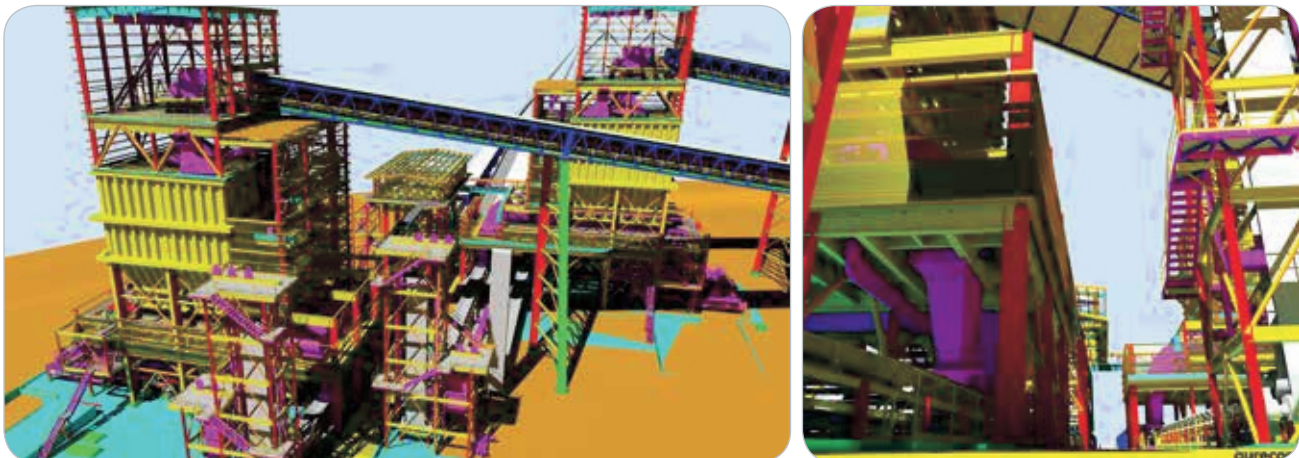



## MINING AND METALS

China Nerin Engineering Co. Ltd.

### Tongling Nonferrous Metals Copper Smelting Project

Tongling, China

The USD 1.1 billion copper smelting factory in Tongling, China, uses advanced flash smelting and flash converting technology to produce an annual output of 400,000 tons of cathode copper and 1.45 million tons of sulfuric acid. The 3D engineering design work – from basic to detailed design – encompassed 15 disciplines. Collaborative technology enabled some of the work to be done by designers at headquarters instead of on site, which reduced labor hours by 35 percent compared to comparable projects.

China Nerin Engineering completed basic design, detailed design, and technical service within 16 months using Bentley PlantSpace for 3D factory design and ProjectWise for collaborative design management, which reduced changes by 56 percent. Optimizing the plant configuration decreased space requirements, reducing construction investment by 10 percent, and 3D construction planning shortened the 36-month schedule by nine weeks.



MECON Limited

### Wire Rod Mill

Visakhapatnam, India

MECON provided services for the USD 135 million Wire Rod Mill at an integrated steel plant in Visakhapatnam, India. The mill has interconnecting piping for oxygen, nitrogen, chilled water, high-pressure water, instrument air, hydraulic oil, lubricating oil, and grease. The piping is laid out by system and runs along the entire mill at different levels and across various locations.

Using AutoPLANT, ProSteel, and Bentley Navigator saved man-hours and costs by allowing designers to explore multiple what-if scenarios. These analyses reduced engineering time by nearly 30 percent. The software integration added immense value through plant commissioning and handover to the client.

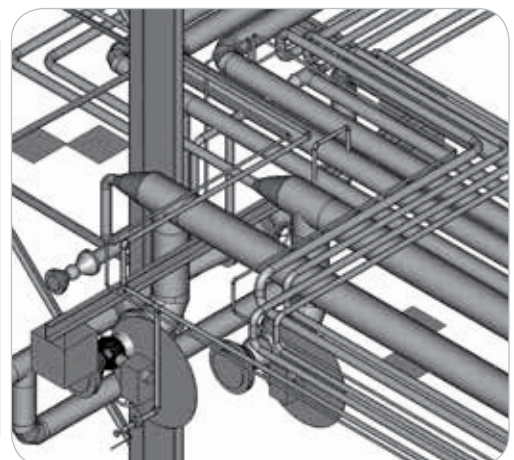
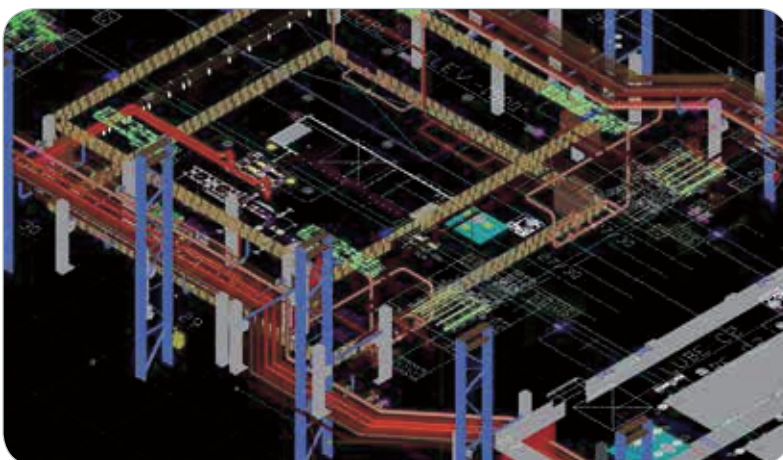

# MINING AND METALS

MMX Mineracao e Metalicos S.A.

## Sistema MMX Minas-Rio

Belo Horizonte, Rio de Janeiro, and Sao Paulo, Brazil

The Sistema Minas-Rio mine is projected to produce nearly 27 million metric tons of iron ore when it reaches full capacity by 2011. The operation will ensure an efficient export corridor for center-west and southeast Brazil, spurring the nation's economic growth. This project is particularly noteworthy for its vast reserves in Minas Gerais state, which might hold 2 billion tons of iron ore.

Due to the size of the project MMX needed to subcontract several EPCs and equipment providers, supplying hundreds of thousands of files to MMX engineers. ProjectWise provided MMX with the tools to coordinate, control, and automate the vast information flow. For instance, when MMX received a new package of documents, these tools automatically checked the integrity of the information before sending the new documents to related disciplines.



Turkish Hard Coal Mining Authority

## Gas Tracing at -1,000 Meters With Bentley Geo Web Publisher

Zonguldak, Turkey

The Turkish Hard Coal Mining Authority digitized 1,200 archived paper maps to improve accessibility and productivity for all project teams. In addition, galleries, wells, shafts, boreholes, and equipment for five branches were modeled in MicroStation. The USD 350,000 project encompassed 300 kilometers of galleries, 8 million tons of coal reserve, and 250 boreholes.

ProjectWise and Bentley Navigator enabled project collaboration and data standardization, which reduced man-hours by about 15 percent. A significant part of the final data was published using Bentley Geo Web Publisher and now enables the authority to monitor gas-tracing sensors located in the galleries and take precautions in case of emergency, making it an effective emergency warning system.

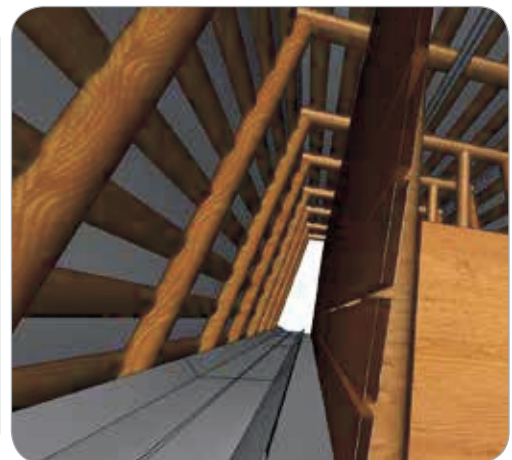
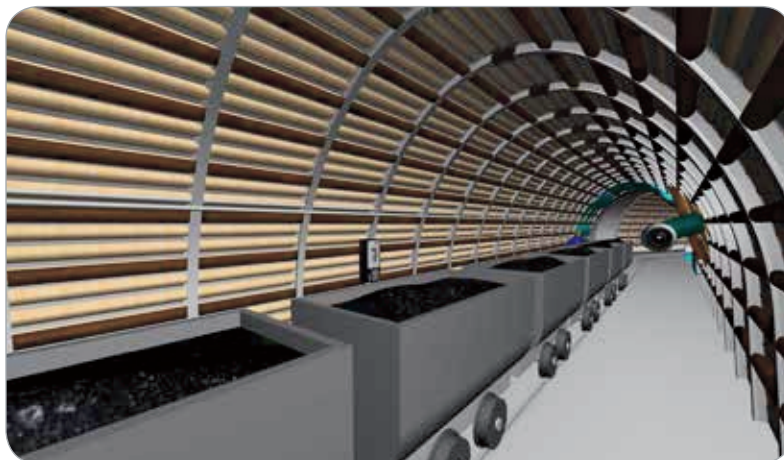

# OFFSHORE ENGINEERING

The projects in this category represent tremendous innovation in the use of Bentley software to produce intelligent infrastructure that is measured in terms of operational efficiency, constructability, safety, and use of energy and non-renewable resources in marine environments. This category recognizes projects that have created new and sustainable value in every stage of the facility lifecycle.



# OFFSHORE ENGINEERING

CNGS Engineering

## Ice-resistant Offshore Platform LSP-1

Caspian Sea, Russia

Designed for offshore oil field development on the northern shelf of the Caspian Sea, the LSP-1 is an ice-resistant stationary 20,000-ton platform that has a fixed rig and custom-designed steel-plate jacket. The support units were designed to sustain the platform's massive weight as well as prevent ice load damage. Using 3D modeling from design through construction staging enabled CNGS Engineering to design the platform in less than one year.

The company used a variety of Bentley software for the 3D design of the piping systems and steel structures. Steel structures were designed with Structural Modeler; piping systems were designed with Bentley PlantSpace; and other systems were designed with MicroStation. Metal strength analyses were double-checked in SACS, and ProjectWise enabled team members in different locations to collaborate.



2012 *BE INSPIRED* AWARD FINALIST

CNGS Engineering

## LAM-B Wellhead Platform

Simferopol, Ukraine

The LAM-B fixed platform is located at the Jeytun oil field in the Caspian Sea off the coast of Turkmenistan. It is designed for oil production, preparation, and transportation to the offshore subsea pipelines. CNGS Engineering provided EPC services including project management, engineering design, fabrication of the support jacket and deck sections, and procurement of components including process equipment, and control and power supply systems as well as installation and commissioning of the platform.

MicroStation-based plant design tools created a single 3D model and enabled the automatic generation of the drawings (plans, drawings) and isometric drawings, significantly reducing the time to create these deliverables and material take-offs. Together with ProjectWise, mistakes were avoided relating to usage of irrelevant documents' revisions, and allocation of the right of access resulted in increase of a safety level both commercially and technically.



2009 *BE INSPIRED* AWARD FINALIST

Dockwise provides transportation, logistics, project management, procurement, and engineering for heavy marine transports. Headquartered in Breda, Netherlands, the company has offices in eight global cities. It chose ProjectWise to integrate engineering worldwide, improve efficiency and quality control, streamline approval processes, and allow access to and reuse of project history.

The implementation uses a central ProjectWise integration server in Breda, caching servers in Houston and Shanghai, and ProjectWise InterPlot at every office. With access from any office or a virtual private network, users can now review, decline, and approve drawings worldwide, resulting in less waiting time. Strict version controls have also produced higher quality drawings that require less rework.

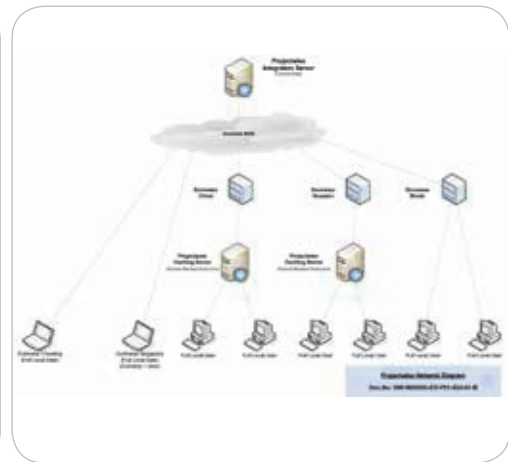
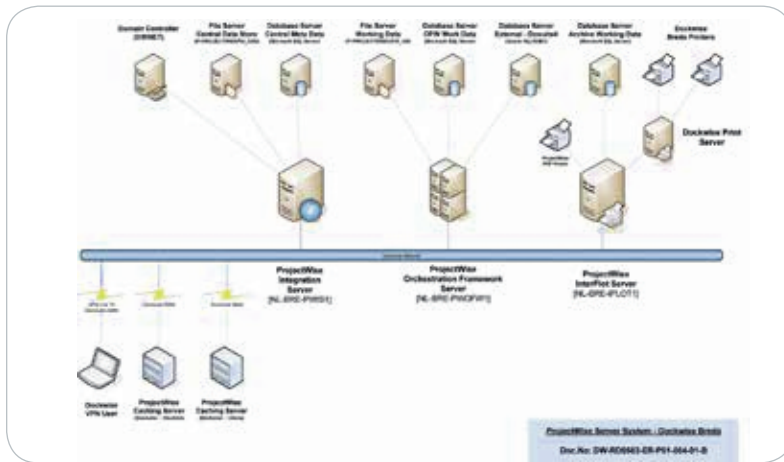





# OIL AND GAS

When designing, constructing, managing, and operating upstream and downstream oil and gas production facilities, the management of crucial information throughout the lifecycle is critical. This category covers a wide range of technological innovation in the oil and gas industry ranging from mapping the fields and preparing new drill-site locations to the design, construction, operations, and maintenance of gas processing plants, oil production facilities, and complex refineries.

# OIL AND GAS

AMCDE

## Khursaniyah, Qatif, and Manifa Water Injection System

Al Khobar, Saudi Arabia

AMCDE sought to maintain oil reservoir pressure and increase oil recovery from an existing reservoir by injecting water back into the reservoir to increase pressure and stimulate production. The greatest challenge for this Saudi Arabian firm was meeting a compressed schedule as a result of the high demand for crude oil and the hike in oil prices. A secondary challenge was connecting design disciplines in various locations.

The team achieved this by using Bentley's collaboration technology with project administrators controlling all deliverables. Bentley's rich security features enabled error-free and on-time project deliverables. Built-in communication tools enhanced interaction among project teams, and ProjectWise allowed for proper monitoring and control by prohibiting unauthorized access to the project's 15,000 to 20,000 drawings and documents.

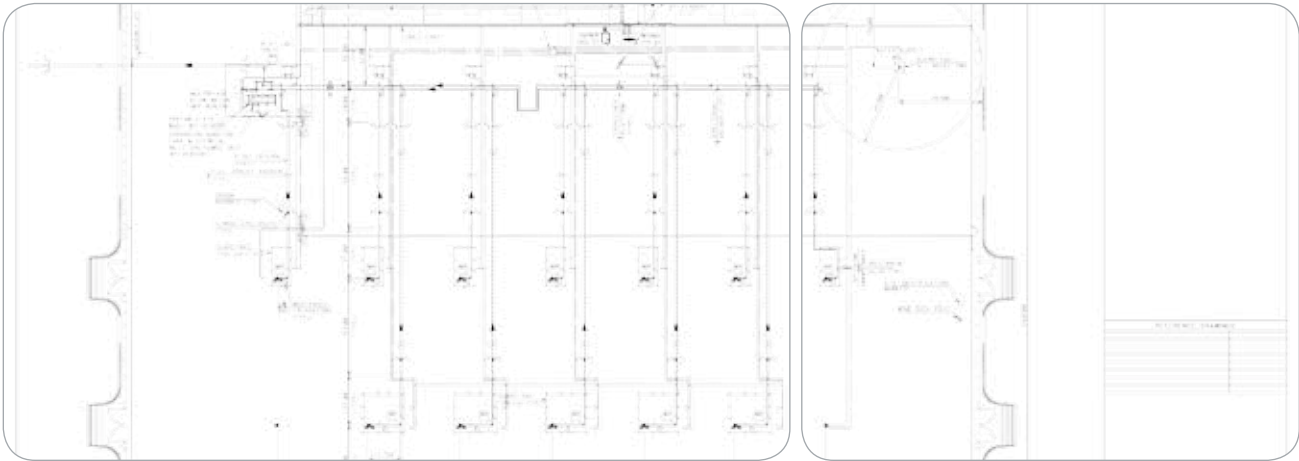

## China Petroleum Engineering & Construction Corp. East-China Design Institute

### CNPCCEI Collaborative Management

Qingdao, China

China Petroleum Engineering & Construction Corp. East-China Design Institute (CNPCCEI) manages engineering, procurement, and construction projects such as large-scale oil refineries. In the past, project files were dispersed among designers, making it hard to obtain accurate information in a timely and effective way. Manual document control procedures were time consuming, with no centralized access and ineffective version control.

CNPCCEI implemented ProjectWise in 2009 and has since managed 67 engineering, procurement, and construction projects with more than 230,000 files. File management, version control, and usage problems were resolved. Document control was simplified and collaboration among branch offices flourished. ProjectWise resulted in time savings of at least 20 percent. The reduced man-hours lowered project costs by about 5 percent.

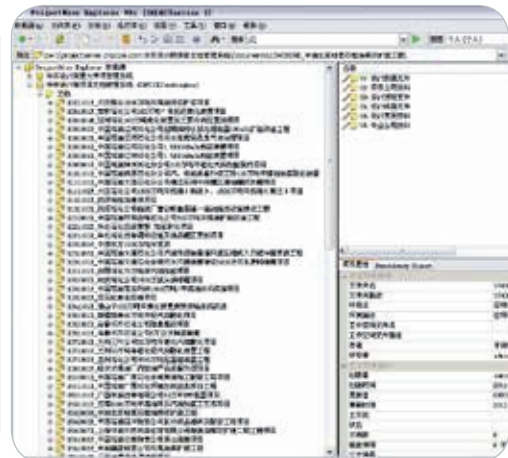
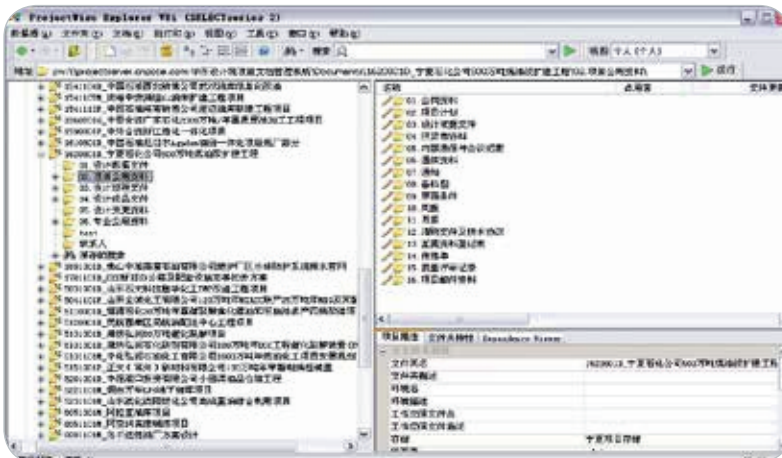

Giprotyumenneftegaz

**Booster Pump Station With Preliminary Water Discharge Facility**

Yugra, Russia

Located in the Priobskoye field of the Yugansk oil region in the Khanty-Mansi Autonomous Okrug of Russia, this project involved the design of several connected facilities – process site, industrial zone, administrative and common buildings, and engineering facilities. Specialists from many different disciplines took part in the design, including surveyors, technologists, architects, sanitary engineers, electrical engineers, and specialists in CAM and telecom.

Giprotyumenneftegaz used Bentley software at all stages, ranging from the engineering survey to functional design, plot planning, physical design, and estimate documentation. With the great number of objects under design, the digital information content included about 6,000 files, including engineering survey maps, models, drawings, general explanatory notes, estimates, and equipment specifications, totaling more than 30 gigabytes.

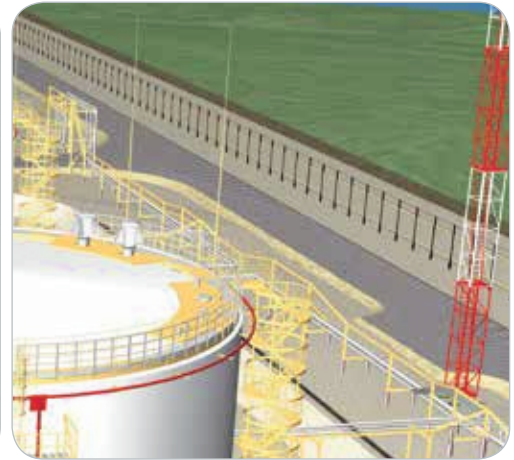
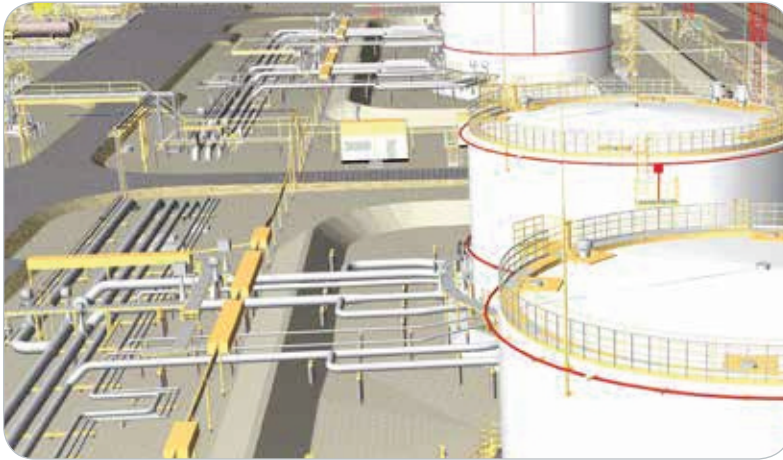
2008 *BE INSPIRED* AWARD WINNER

PechorNIPIneft

**Construction of Booster Oil-refining Station on Bayanduskoe Oil Field**

Usinsk, Russia

LUKOIL is an international, vertically integrated oil and gas company. LUKOIL's subsidiary, PechorNIPIneft, designed a booster station for the oil refinery at the Bayanduskoe oil field located near Usinsk. The team used a common platform for team member interaction and facilitated the process of coordinating and approving design solutions.

AutoPLANT and Bentley Navigator were used for 3D modeling to reduce design errors and conflicts. ProjectWise was used to accelerate information sharing and communications across the project team. As a result, the time taken to release design documentation for new objects was reduced by 15 to 20 percent.





# OIL AND GAS

Petrofac Brownfield

## Documentation Management Systems Upgrade

Aberdeen, United Kingdom

Based in Aberdeen, United Kingdom, Petrofac Brownfield upgraded its existing document management systems to gain control of all work-in-progress documentation and achieve its strategic objective of working globally and collaboratively. The project was designed to provide operational efficiencies for the company, its clients, and subcontractors on projects around the world.

The two-part implementation included a document control server and work-in-progress document management. ProjectWise facilitated the use of 3D models in disparate locations, and after three months of operation, the firm was able to reduce its engineering norms by 5 percent on deliverables. This reduction was achieved through efficiencies in the document lifecycle.

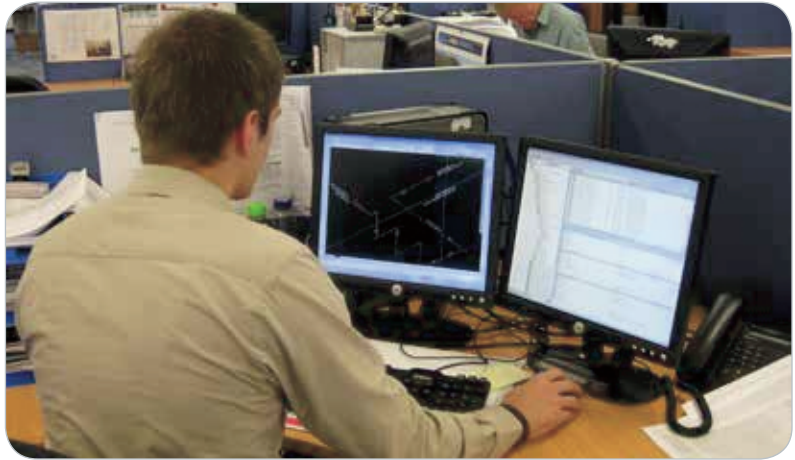

# POWER GENERATION

Power professionals from the largest utility to the smallest rural or municipal utility work to efficiently produce and deliver energy. They share the common goals of improving efficiency, reducing cost, and delivering better customer service while sustaining and expanding aging power generation plants and adding new generation capacity. This category recognizes innovative projects ranging from the traditional fossil fuel power plants to nuclear power stations and renewable energy sources such as hydroelectricity, solar, and wind power.

# POWER GENERATION

Camargo Corrêa

## Jirau Hydropower Plant

Porto Velho, Brazil

Located on the Madeira River in northwestern Brazil, the Jirau Hydropower Project will have a capacity of 3,750 megawatts generated by 46 turbines. Construction is being undertaken by a consortium of companies that includes Camargo Corrêa to design, construct, and operate one of the largest hydropower plants in the world that will ultimately supply energy for more than 10 million families.

Using ProjectWise allowed Camargo Corrêa to implement a controlled and transparent workflow and deploy a decentralized workforce of 200 users, all of which reduced approval time of documents and contracts up to 17 days and decreased work accidents by approximately 3 percent. ProjectWise's real-time management information for decision making enabled the firm to participate in the second biggest hydropower plant under construction in Brazil.

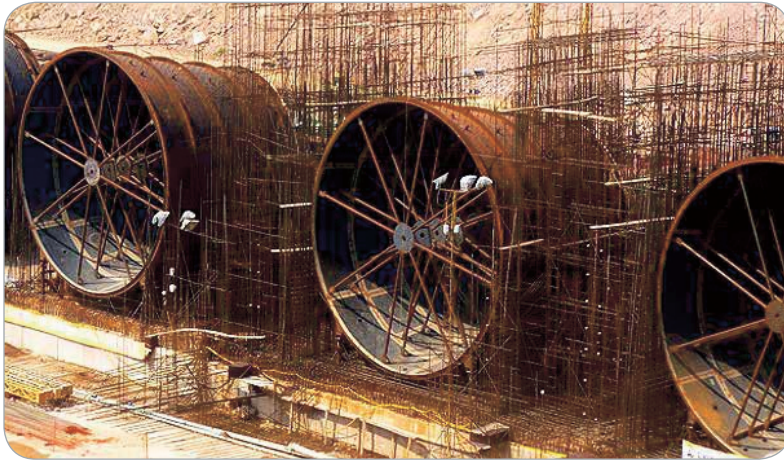

Camargo Corrêa/CNEC Engenharia

## Serra do Facão Hydroelectric Power Plant

Catalao, Brazil

Located on the São Marcos River in central Brazil, the USD 400 million Serra do Facão Hydroelectric plant will provide energy to a region experiencing a high level of economic growth. Development of the facility posed a challenge for the multidisciplinary project team, which was geographically dispersed throughout the local site engineering office, project partners, and the contract owner.

The solution was to use the collaborative technology of ProjectWise, which reduced travel time and provided team members with access to the right information in real time. ProjectWise reduced total project time by an estimated 20 percent.





# POWER GENERATION

## Energoprojekt Gliwice SA Gas-Fired CHPP Glogow and Polkowice Glogow and Polkowice, Poland

KGHM Polska Miedz S.A. selected Energoprojekt Gliwice SA (EPG) as the primary engineer and coordinator for two combined heat and power plants. The project was executed in cooperation with another engineering company. Because the plants were similar, each design discipline was assigned the scope of work for both locations. Both offices used 3D design technology in DGN format.

PlantSpace was the main design platform and ProjectWise was the document management system (DMS). With a customized integration server at EPG and a caching server in the work-sharing office, all participants collaborated on an up-to-date 3D model. EPG also synchronized data exchange between ProjectWise and its ERP system, reducing DMS and ERP administration from three to two teams. EPG estimated total time savings of more than 2,130 hours.

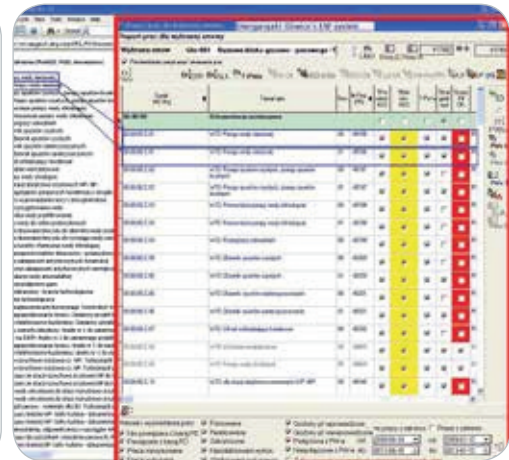
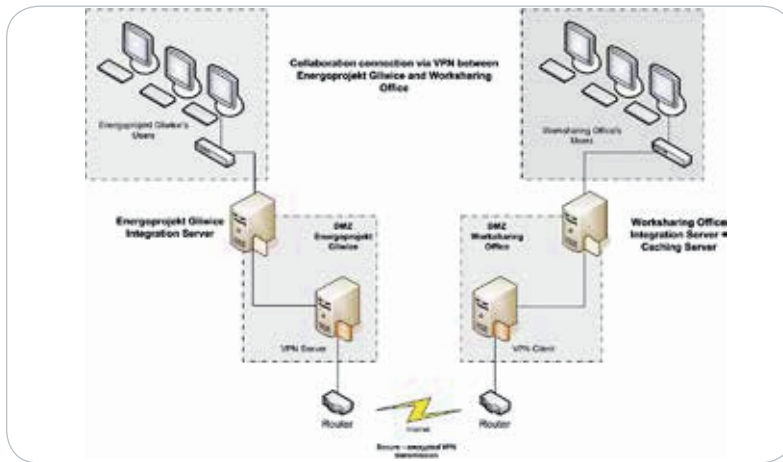

## Engevix Engenharia S.A. Caçu Hydroelectric Power Plant Caçu, Brazil

The Caçu Hydroelectric Power Plant, a 65-megawatt facility located in midwest Brazil, will generate enough energy to provide electricity to 470,000 people. Because project teams were dispersed across six cities, Engevix Engenharia re-evaluated existing workflows and implemented plans for optimization, adaptation, and transfer of responsibilities to preserve and assure quality.

ProjectWise automated messages for improved communication, controlled workflows and work products, organized groups and access lists, and integrated the managed workspaces into a controlled environment. The software minimized time spent searching for and circulating documents and reduced production time by about 40 percent. ProjectWise provided an immediate and accurate view of the project's status and a record of each collaborator's responsibilities and actions.

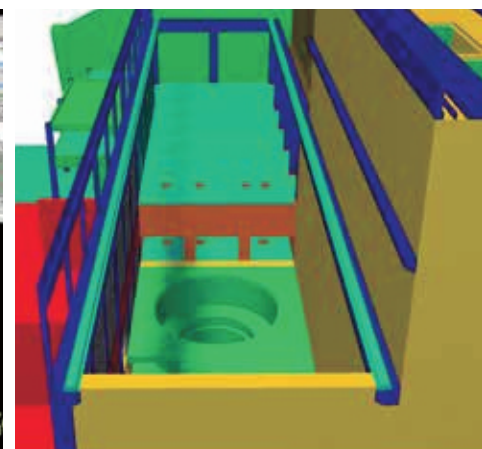
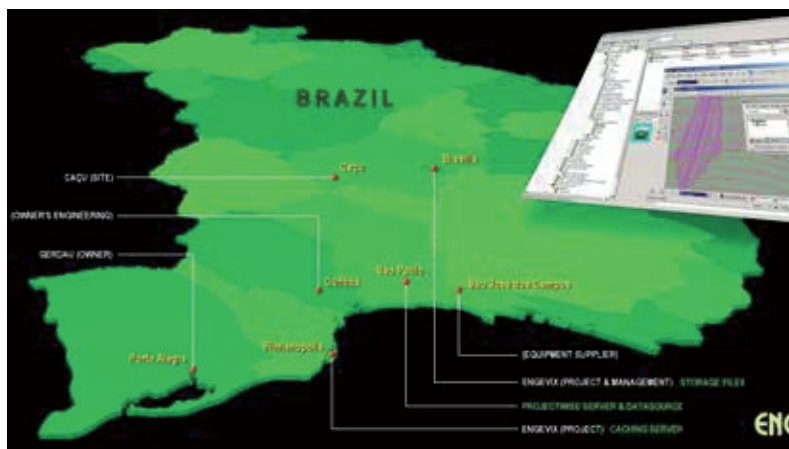

2008 BE INSPIRED AWARD FINALIST

# POWER GENERATION

Eskom

## Integrated Engineering Management System for Eskom Lethabo Power Station

Vereeniging, South Africa

The goal of this project in South Africa was to implement an integrated engineering business process and engineering documentation management system to provide the power station with standardized processes, consolidation and integration capabilities, visibility of and access to engineering information, control of engineering processes, and a digital plant visual platform.

The project required a greenfield implementation of document management technology, creation of new intelligent drafting symbology and standards, and extensive retrofit of historical engineering and plant information. A customized ProjectWise system enabled advanced workflow capabilities and user management.

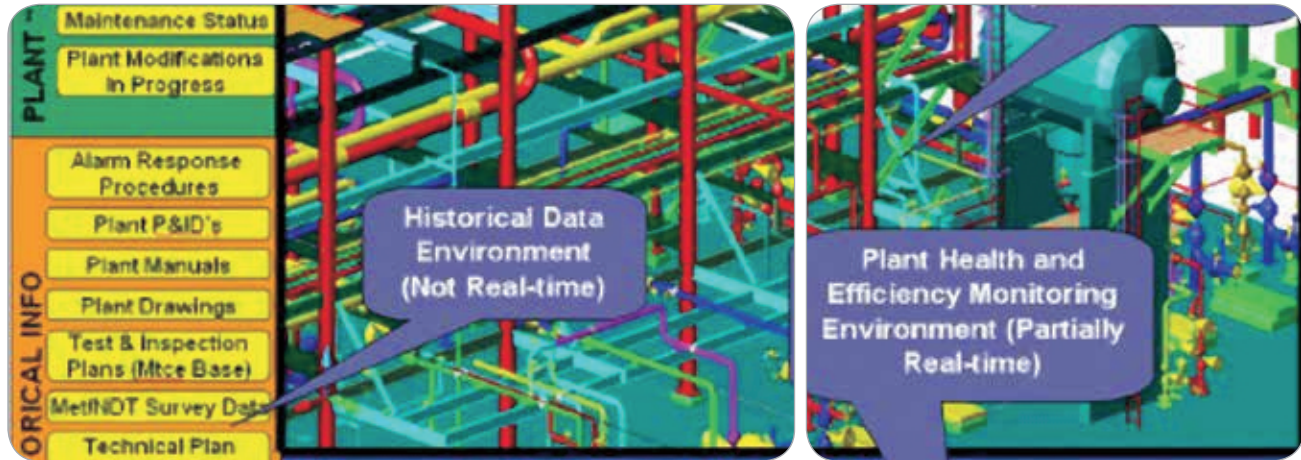

2008 *BE INSPIRED* AWARD FINALIST

HydroChina Zhongnan Engineering Corporation

## Tuoba Hydro-Power Station

Diqing, China

The USD 1.9 billion Tuoba Hydro-Power Station will provide China's Guangdong Province with 410 megawatts of renewable energy each year. HydroChina Zhongnan Engineering shortened design time from six months to 39 days. MicroStation, Bentley Architecture, Structural Modeler, GEOPAK, PlantSpace, promis•e, Bentley Navigator, and Bentley Substation improved design efficiency, and facilitated communication and cooperation among disciplines.

ProjectWise connected on-site designers with headquarters, ensuring everyone used the enterprise standards and latest file versions. This technology saved HydroChina Zhongnan 50 percent of the cost associated with managing enterprise standards. Other efficiencies gained included shortening layout design time from one or two weeks to less than eight hours and cutting final drawing production time from two or three days to just one day.



2011 *BE INSPIRED* AWARD FINALIST



## POWER GENERATION

### Korea District Heating Co., Ltd Paju Combined Heat and Power Plant Seongnam-si, South Korea

The USD 70 million Paju Combined Heat and Power Plant will supply district heating water and electricity to approximately 57,000 apartments in Paju City, located northwest of the capital city of Seoul. The 515 megawatt power plant was commissioned by the Korea District Heating Co. and has a district heating capacity of 553 gram calories per hour.

Korea District Heating used MicroStation, ProjectWise, PlantSpace, Structural Modeler, and Bentley Navigator to develop a quality design in consultation with design team members, partners, and the owner. Sharing of the latest information and visual design reviews facilitated collaboration. The solutions significantly reduced rework by enabling interference reviews, which shortened the entire construction period by three weeks.



### Leningrad Nuclear Power Plant Information System “Decommissioning Database of Leningrad Nuclear Power Plant”

Leningrad, Russia

The Leningrad Nuclear Power Plant began operation in 1966 with a service life that expires in 2015. Decommissioning the facility can take as long as 90 years so large-scale dismantling of the facility won't begin until the 22nd century. However, a system to archive all necessary information for the future generations of specialists that will work on the decommissioning was needed to avoid mistakes when the decontaminating and dismantling is performed in future years.

The project team used ProjectWise as the core system for managing documents and other information. The team converted technical documentation to electronic form and placed it in managed storage. Additionally, Bentley's PlantSpace technology allowed the team to develop complicated large-scale 3D models of the facilities for decommissioning.

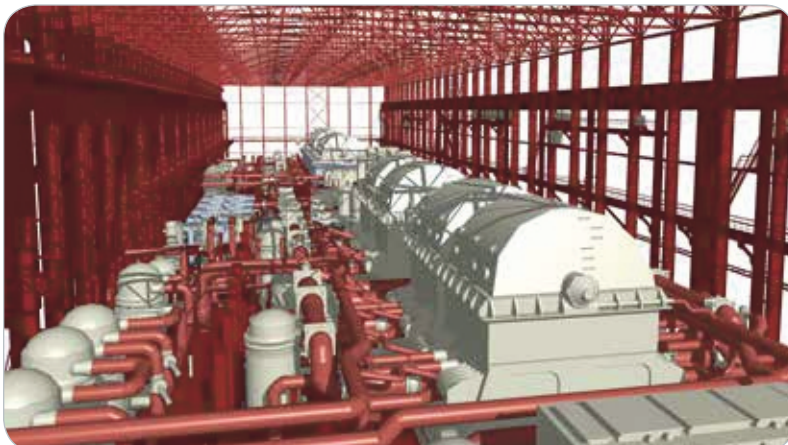





# PROCESS MANUFACTURING

This category covers a wide range of industries including upstream and downstream oil and gas facilities, petrochemical and chemical complexes, pharmaceutical and manufacturing plants, and more. For greenfield plants and retrofits to existing plants, safety and environmental concerns are at the top of the priority list, and the management of engineering information and innovative use of technology are critical to achieving project success and process improvements.

# PROCESS MANUFACTURING

Bharat Oman Refineries Limited

## ProjectWise Implementation at BORL Refinery

Bina, India

Bharat Oman Refineries Limited (BORL) built a 6 million metric ton per annum refinery in Madhya Pradesh, India. The complex includes crude oil receipt and dispatch facilities, a 935-kilometer cross-country pipeline, a 99 megawatt captive cogeneration power plant, and infrastructure. During construction, issues arose with vendor document access and version control. Project teams in multiple locations had trouble sharing information, and as-built data needed to be secured against unauthorized access and modification.

BORL deployed ProjectWise to resolve these issues and manage project documents in an efficient, organized, and secure way. Departments such as maintenance, operation, process, commercial, and legal also used ProjectWise. The system saved time finding, validating, and accessing information across departments. ProjectWise reduced risk and minimized downtime during operation and maintenance after commissioning.

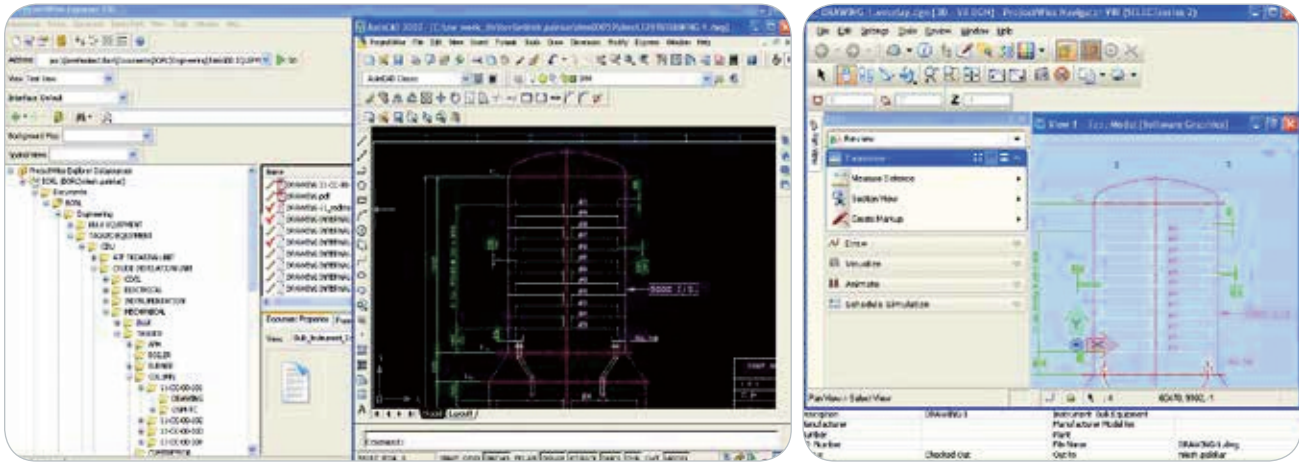

Camargo Corrêa

## Comperj Petrochemical Plant

Itaboraí, Brazil

Rio de Janeiro's Petrochemical Complex (Comperj) will be constructed on a 45-million-square-meter area located in Itaboraí, Brazil, with investments of USD 8.38 billion. When operations begin in 2012, Comperj will process about 150,000 barrels per day of heavy oil. The project partners implemented ProjectWise to connect team members in distant locations.

ProjectWise was integrated with Microsoft SharePoint and used in conjunction with Aveva's plant design management system (PDMS) to improve team performance, facilitate collaboration by enabling efficient file exchange, and expedite the design approval process. The total time on the project was reduced by 15 percent as a result of deploying the technology.

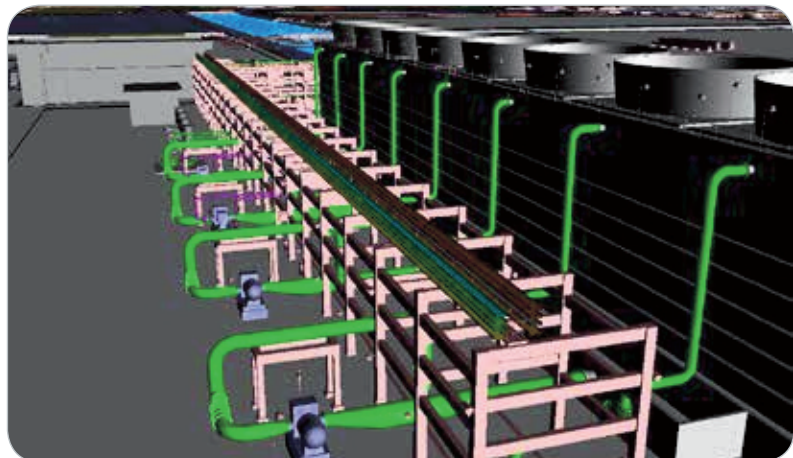
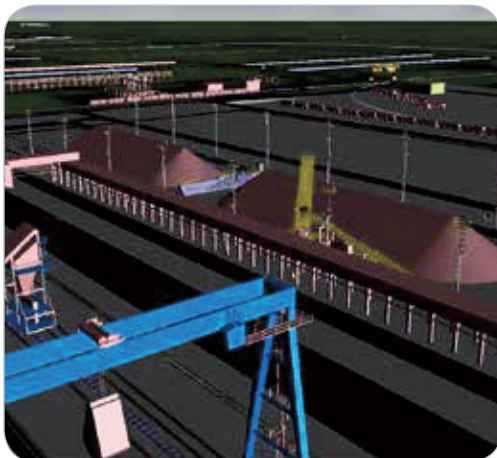



## PROCESS MANUFACTURING

Continuus-Properzi S.p.A.

### Engineering Collaboration With ProjectWise

Sordio, Italy

Continuus-Properzi produces non-ferrous rods for worldwide distribution. Each year, the technical department manager coordinates production and revision of more than 50,000 mechanical and electrical CAD design files, technical reports, specifications, and manuals for design and delivery of new machinery. This documentation was being distributed to multiple departments, making it impossible to correlate data and find project information.

ProjectWise was introduced to give the departments secure and controlled access to documents. Metadata with appropriate coding, categorization, and descriptions eliminated problems with finding, correlating, and sharing data. In addition, field engineers working on Properzi lines all over the world also access data on the Milan, Italy, server as if they were at company headquarters.



GE Water & Process Technologies

### Automated Drawing Release Using ProjectWise

Burlington, Massachusetts, United States

GE Water & Process Technologies saved on labor costs by automating the release of P&ID, piping assembly, and fabrication drawings. The previously manual process involved creating and uploading PDFs to a document repository, creating records in the enterprise resource planning system, and linking the records to the PDF files. The system paid for itself in less than a year.

Using ProjectWise, GE now publishes PDFs automatically based on the status of drawings in ProjectWise. With MicroStation as the plotting engine, PDFs are published from both DWG and DGN formats. The PDFs are automatically uploaded to ProjectWise and linked to the enterprise resource planning system. The automated process is predicted to save 500 man-hours per year for an annual cost savings in excess of USD 36,000 for this Burlington, Mass., project.



# PROCESS MANUFACTURING

GEA Process Engineering France

## Engineering Collaboration Using ProjectWise

Saint Quentin en Yvelines, France

GEA Process Engineering France is increasing its business in emerging markets via local companies supported by technology centers based in Europe. The goal of this project was to provide a competitive design office and to develop activity in the GEA Process Engineering (India) office in the upcoming years.

Using ProjectWise and PlantSpace, GEA shared CAD management and library development activities with other companies in the group. GEA's milk and chemical evaporation activities especially benefited from ProjectWise, which enabled the company to standardize the engineering organization and methodology.

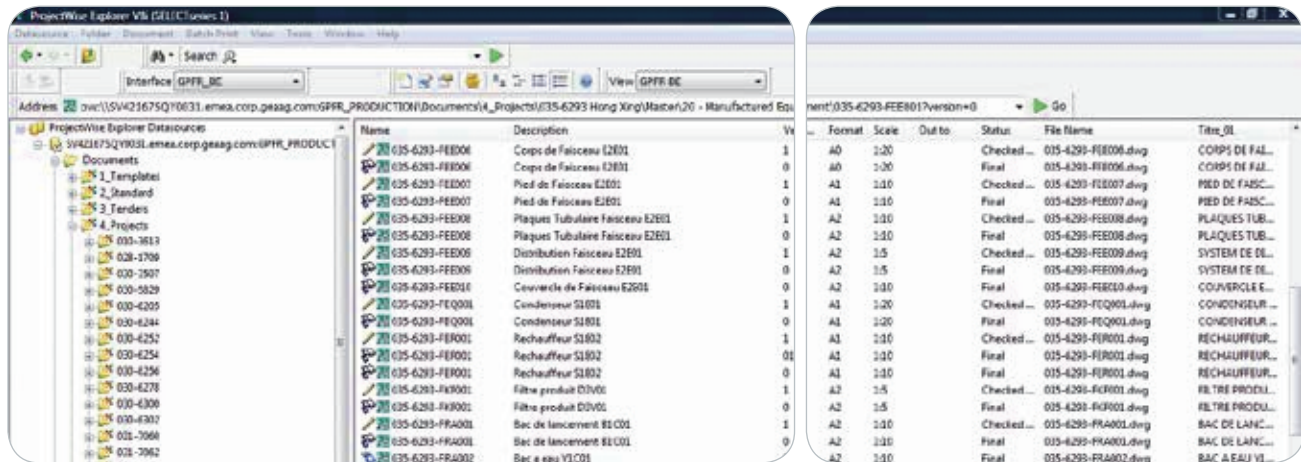

Hatch Associates, Limited

## Coal Preparation Plant Raw Coal and Reliability Improvement Project

Wollongong, Australia

To execute detailed design for a coal preparation plant improvement project in New South Wales, Australia, Hatch had to draw upon discipline experts and resources in five offices around the world. ProjectWise facilitated work-sharing and collaboration among the offices to maximize engineering and design productivity. Caching servers were deployed locally for fast, LAN-like access.

With multiple disciplines working simultaneously in different locations and time zones, ProjectWise improved data security and interoperability. Appropriate policy, security, and audit issues were explored and identified; and conformance to standards and specifications among Bentley and third-party applications was verified. This saved hours of remodeling. Hatch's standard workflows and practices were integrated into the system to ensure quality deliverables.

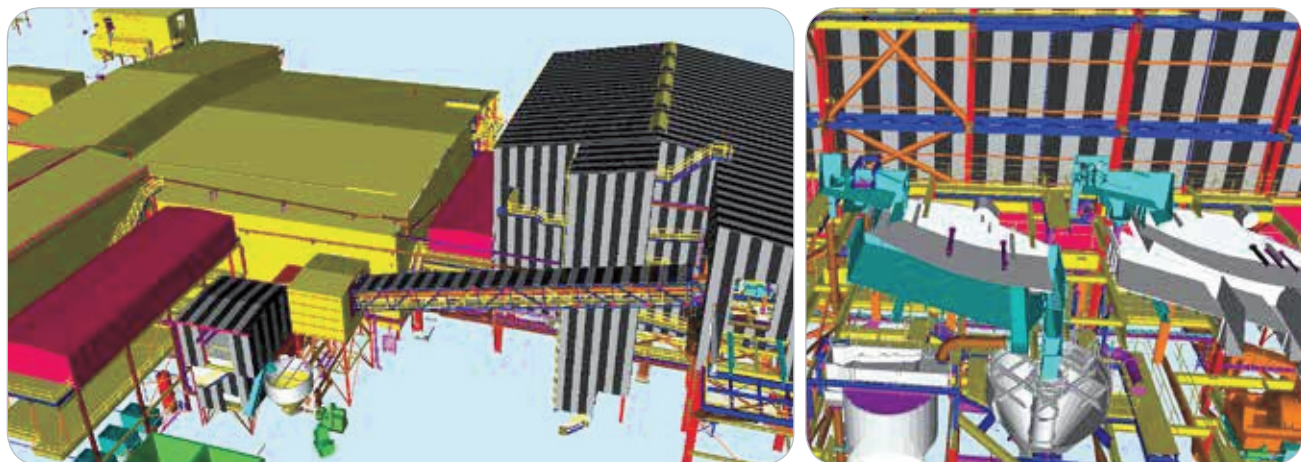



## PROCESS MANUFACTURING

Larsen & Toubro Limited  
**Motor Spirit Quality Upgrade**  
Panipat, India

The newly commissioned Motor Spirit Quality Upgradation Plant in Panipat, India, is one of the first refineries to achieve Euro-III norms. A truly green fuel, gasoline produced at the Panipat Refinery will have minimal levels of benzene and sulphur. Larsen & Toubro performed project management services as well as engineering, procurement, commissioning, and performance guarantee.

Using ProjectWise, the project team collaborated from offices located in different cities across the country. Despite changes in a scope from the construction team, schedule progress was maintained while targets were adjusted. General arrangement drawings and various layouts were extracted from the project, and approximately 10 to 12 percent of the project resources were saved.



Tessenderlo Group  
**MOC IN 3D-PDF Is Top**  
Tessenderlo, Belgium

Information sharing presents many challenges during the lifecycle of a petrochemical plant, from basic to detailed engineering through construction supervision. A 3D model allows this information to be validated and managed throughout the 40- to 50-year life of the plant to ensure safe and efficient operation.

Tessenderlo Group uses Bentley Navigator to generate data-rich 3D models in PDF format for distribution, collaboration, and archiving. Adobe Reader is used to review the documents and add comments, redlines, and notes. This ensures that everyone has access to one up-to-date PDF file without having to install extra software. The files are archived in the ProjectWise document management system.





# PROCESS MANUFACTURING

Toyo Engineering India Limited

## Enhancing Project Delivery Using ProjectWise

Mumbai, India

Toyo India is a leading design, engineering, consultancy, and contracting company for the oil and gas, petrochemical, and infrastructure sectors in India and overseas. With multiple parallel projects straining company resources, conformance with standards was challenging and access to project documents was difficult for remote teams and external participants.

Toyo India deployed ProjectWise to create a safe, secure, and reliable collaboration environment. ProjectWise Integration Server provided efficient data storage and fast access with delta file transfer. ProjectWise Web Server gave external stakeholders controlled access. The implementation improved project information sharing and management while securing access to documents by internal and external participants.

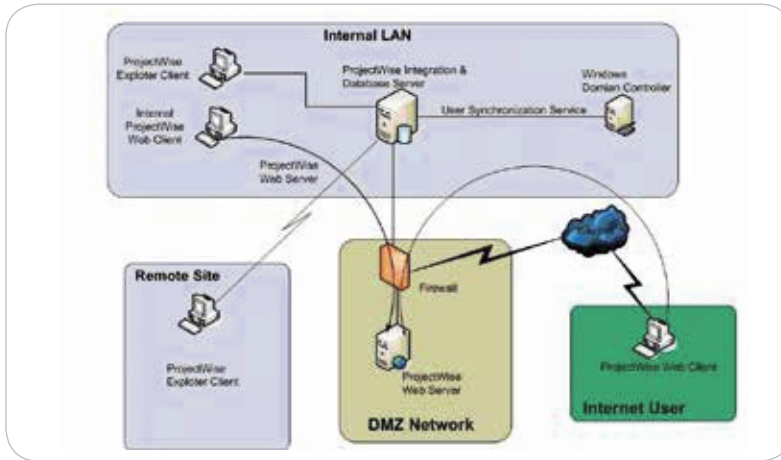

The screenshot shows the ProjectWise software interface for 'HV & MV CABLE SIZING CALCULATIONS'. The interface includes a menu bar (General, Security, Properties, More Attributes, File Properties, Audit Trail, Workspace, Components) and a main data entry area. The data entry area contains the following fields:

DOC_NUMBER	6782EPC3-10-334-ELE-00-4001	DOC_REV	1		
DOC_TITLE	HV & MV CABLE SIZING CALCULATIONS				
DOC_CODE	6782EPC3-10-334-ELE-00-4001	TASK	In progress		
PROJECT_NO	6782				
DOC_DISCIPLINE	ELE				
DOC_PTYPE	CABLE LAYD	PKG	EPCC3		
UNIT_NUMBER	334				
DOC_SEQUENCE					
DOC_SHEET_NO					
DOC_SHEET_DATE	9/20/2010	TRANSMITAL_NO	EPCC3/TH/EN/6782-DT/0054		
DOC_SHEET_MARK		TRANSMITAL_DATE	9/20/2010		
DOC_SHEET_STAGE		TRANSMITAL_RECEIVE_DATE			
REVIEW_CATEGORY					
APP_PLANNED_DATE	1/28/2010	APP_DATE		APP_FOLLOWUP_DATE	
AFD_PLANNED_DATE	4/15/2010	AFD_DATE		AFD_FOLLOWUP_DATE	
AFC_PLANNED_DATE		AFC_DATE		AFC_FOLLOWUP_DATE	
APPROVAL_CT	CODE1_APPRI				



# RAIL AND TRANSIT

The projects in this category share the common goals of driving down maintenance costs, improving asset knowledge and reliability, managing rail real estate, renewing and reconfiguring existing infrastructure, designing and delivering new infrastructure, and planning urban integration. These projects demonstrate innovation in the rail and transit lifecycle, ranging from data collection and design to maintenance and capital project planning.

## RAIL AND TRANSIT

Fluor/HDR Global Design Consultants

### RTD FasTracks Eagle P3 Project

Denver, Colorado, United States

The USD 2.1 billion RTD FasTracks Eagle P3 project is part of the Denver, Colo., Regional Transportation District's (RTD) initiative to expand and improve public transit through three commuter lines, a maintenance facility, and 14 stations. As design lead, Fluor/HDR Global Design Consultants assembled a core team of 210 professionals supported by 300 auxiliary team members scattered across 77 offices in the United States, Europe, and Japan.

ProjectWise allowed team members to access documents and collaborate in real time from any location. Fluor/HDR used ProjectWise-managed workspaces to automatically deploy and update a client/project-specific MicroStation workspace at every location, which saved hundreds of CAD management hours. Using ProjectWise – in conjunction with Bentley Descartes and LEAP CONSPAN – Fluor/HDR saved an estimated USD 3.1 million.



2012 *BE INSPIRED* AWARD FINALIST

## Gautrain

### Gautrain Rapid Rail Link

Johannesburg, South Africa

The growth of the South African province of Gauteng is limited by congested highways and a lack of public transportation. Gautrain proposed a rapid rail link that connects Tshwane to Johannesburg and Sandton to ORTIA International Airport. Trains operating at up to 160 kilometers per hour will travel along 80 kilometers of rail to link 11 stations. The system will be integrated with bus service that will ultimately transport more than 60,000 passengers per hour and reduce the number of cars on parallel roads by 20 percent.

What made this project possible was appointing a consortium of local and international companies and awarding a 20-year concession (five-year construction and development, 15-year operating period) using a public-private partnership. The size and complexity of the consortium demanded an integrated document management and control system to ensure reliable collaboration among all parties. The project team also required a 100 percent secure system for tendering and procurement, organized electronically.



2008 *BE INSPIRED* AWARD WINNER



# RAIL AND TRANSIT

Gemeente Utrecht/POS

## Redevelopment Station Area Utrecht—A Complete Makeover

Utrecht, Netherlands

Located in the center of the Netherlands, Utrecht hosts the country's main railway junction Utrecht Central Station. The number of travelers through the station is expected to double in the next 20 years to 100 million passengers per year. To expand capacity and add amenities, the municipality (Gemeente Utrecht) tasked the project organization station (POS) department with long-term redevelopment of the station.

The CAD department of POS has about 30,000 technical documents, but no metadata was available to help search for proper document versions. POS implemented ProjectWise to store and manage all drawing attributes and linked project attributes in an Oracle database. This has significantly improved access to documents for internal staff and external partners, with time savings of up to 30 percent.



Infotech Enterprises Ltd

## Railway Signaling Design

Hyderabad, India

Headquartered in Hyderabad, India, Infotech Enterprises has 8,700+ associates in 30 global locations. Rail signaling services for the transportation industry incorporate design inputs from associates located in multiple offices. Designs include wiring diagrams, rack assemblies, power system arrangements, and various signaling modules. Their correct integration is vital to safety.

Creating consistent signaling designs on paper created ambiguities for stakeholders. Infotech replaced manual processes with MicroStation tools to more efficiently deliver simple and legible designs. ProjectWise is used to share documents among global offices working on the same designs. Final designs are sent to the appropriate authorities for installation, testing, and commissioning. Installations are quick, cost-effective, and safe.

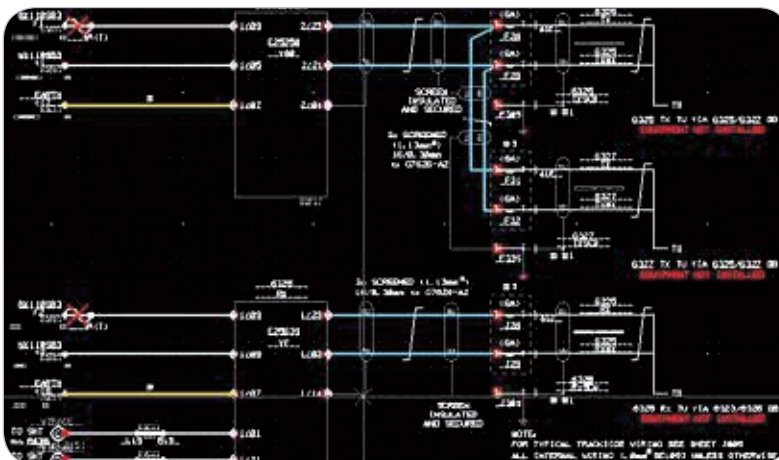

# RAIL AND TRANSIT

MTR Corporation Limited  
**ProjectWise for Railway Business**  
 Hong Kong, China

Four million passengers ride the nine Mass Transit Railway (MTR) lines in Hong Kong every weekday. MTR's existing drawing management system is based on ProjectWise technology and houses more than 1.4 million as-built and working engineering drawings. With 40 percent growth forecast for the number of drawings, an upgrade was required to ensure its continued ability to record, organize, control, and store drawings.

The drawing management system enhancements have improved searching and drawing upload, tightened integration with CAD and building information modeling software, and provided a more user-friendly interface for its 1,500 users. Collaborating in a single environment and navigating files in different formats using a web browser, users more efficiently retrieve information from ProjectWise.

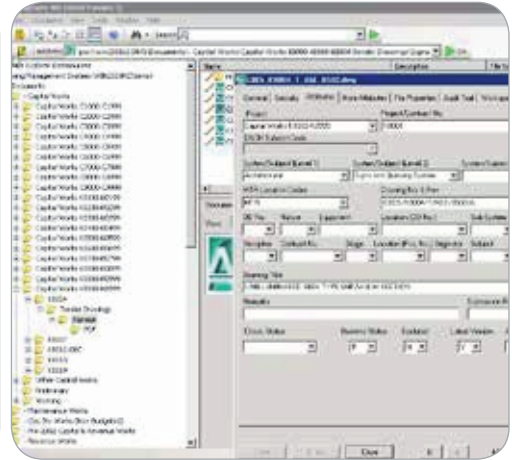

Network Rail  
**Design to Cost Standard Design Catalogue**  
 London, United Kingdom

Network Rail owns, runs, maintains, and develops Britain's tracks, signaling systems, 18 key stations, and more than 40,000 bridges, viaducts, and tunnels. To meet rapidly growing demand, Network Rail developed a delivery plan for a GBP 10 billion program from 2009 to 2014. Tough efficiency targets set by the U.K. rail regulator require GBP 4.1 billion in savings during this same period.

The design-to-cost project aims to contribute GBP 100 million in savings by eliminating repetitive design, avoiding over-specification, and reducing implementation time. A suite of standard designs will be accessible through the Standard Design Catalogue (SDC) hosted by ProjectWise. The ProjectWise-managed environment will ensure that the SDC is up to date for its 4,000+ users, lowering Network Rail's cost to design and deliver.

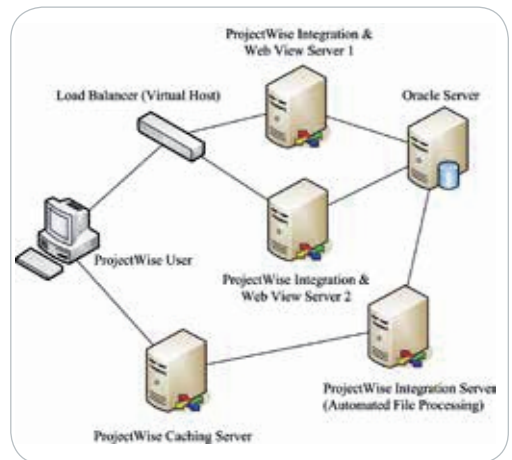
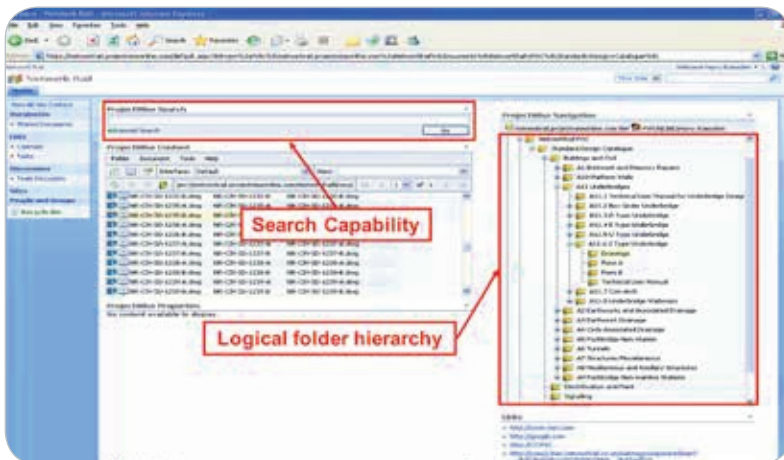



# RAIL AND TRANSIT

Ove Arup & Partners

## Augmented Reality for Fulton Street Transit Center

New York, New York, United States

The USD 1.4 billion Fulton Street Transit Center project in lower Manhattan, N.Y., integrates five existing stations and a national historic landmark building into one transport hub. To convey the scale of the project to stakeholders, Arup worked with Bentley's Applied Research Group to produce an augmented reality model of the site. The model displayed the project elements overlain on a 360-degree photo panorama.

Viewable on a tablet device, the model was geo-referenced and included data on above-ground and underground infrastructure. The model can be interrogated and manipulated to reveal component details and data layers. Bentley Navigator, and iPad apps were used to produce the desired effect, enabling on-site and off-site personnel to interact with the model.

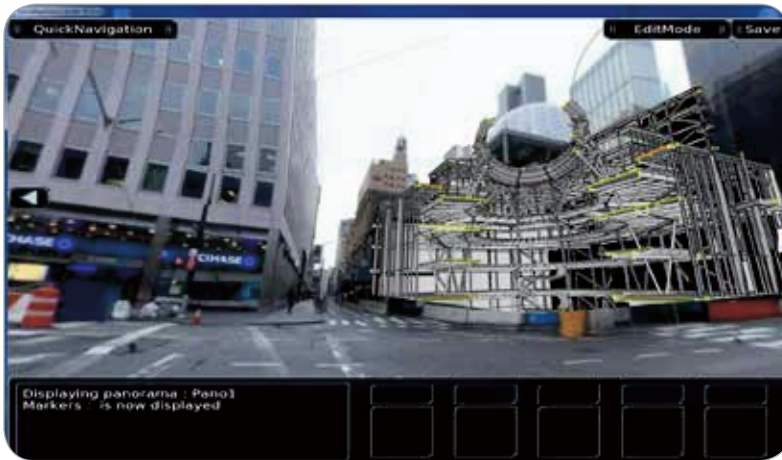

PKP Polskie Linie Kolejowe S.A.

## Information System for Railway Lines (SILK)

Warsaw, Poland

SILK, a USD 625,000 information system for railway lines, was developed to improve decision making for modernizing and developing state railways in Poland. PKP Polskie Linie Kolejowe created this information system as a spatial reference system that catalogs and shares information related to investment, real estate property, and inventory.

The company used Bentley PowerMap, MicroStation, Bentley Geospatial Server, and ProjectWise to develop SILK. ProjectWise enabled users to more efficiently and quickly distribute files and data and to centralize information, and improved information access led to better communications and data flow as well as time and money savings in managing railway investments.

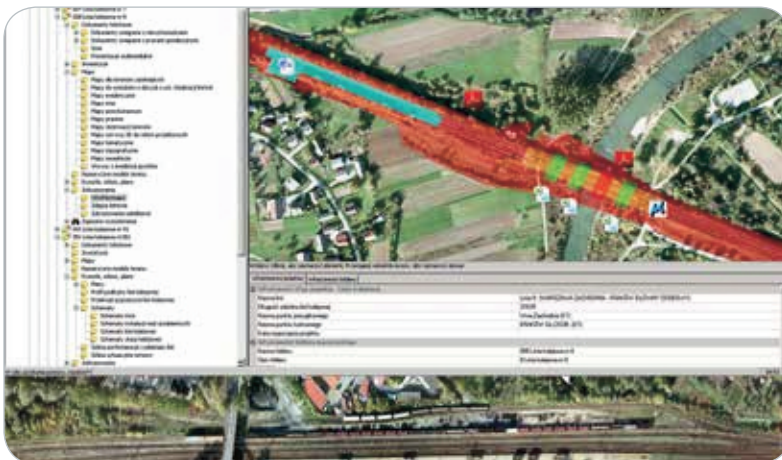



## RAIL AND TRANSIT

URS/Scott Wilson

### Crossrail Farringdon Station

London, United Kingdom

When Crossrail opens in 2017, it will expand London's public rail transport network capacity by 10 percent. As lead designer for the Farringdon Station, URS/Scott Wilson is co-located with Crossrail in Greenwich and is responsible for managing the interface with all stakeholders, including Network Rail, London Underground, and Westminster City Council.

The Crossrail project has specified Bentley software as the preferred design platform, using ProjectWise for collaboration. The project workflows follow BS1192 procedures at all stages. Using ProjectWise, the team can search, locate, and validate engineering information 35 percent faster than on previous projects. URS/Scott Wilson has estimated time savings to date of 62,200 man-hours for cost savings of GBP 2.8 million.

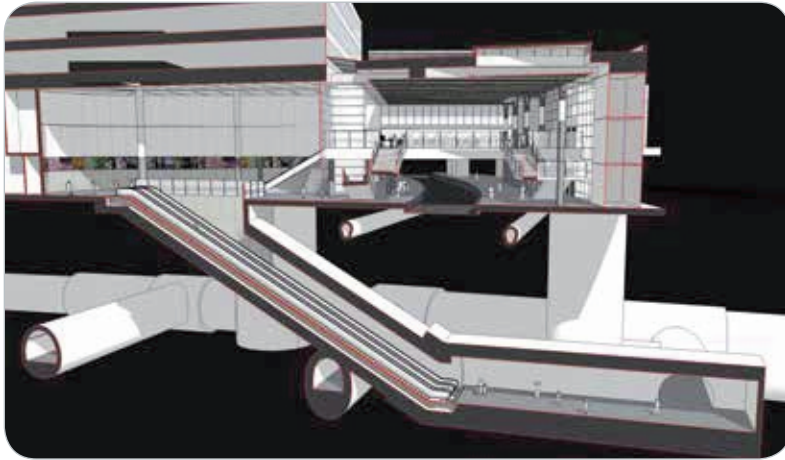

2010 *BE INSPIRED* AWARD FINALIST

URS/Scott Wilson

### East London Line

London, United Kingdom

North and south extensions connect the East London Line with existing rail services to expand the network for the 2012 Summer Olympic Games. URS/Scott Wilson provided design services to the joint venture partners for this project, and its major works included detailed designs for four stations, two warren truss bridges, a bowstring arch bridge, and three viaducts. Detailed designs were also provided for numerous smaller projects.

The global team was connected through ProjectWise for real-time collaboration. ProjectWise connected more than 300 professionals in 15 offices, enabling team members to search, locate, and validate engineering information 25 percent faster than on previous projects. Using ProjectWise, URS/Scott Wilson also accelerated information sharing and communications across the team. This technology will potentially save the client GBP 5.54 million in reduced time costs.



2010 *BE INSPIRED* AWARD FINALIST

# ROADS

The challenge of today's civil and transportation engineers, contractors, governments, and owner-operators is to work more productively, collaborate more globally, and deliver better-performing infrastructure assets. The projects in this category have demonstrated excellence in planning, engineering, analysis, and design of roads or highways in a mission to sustain transportation infrastructure.

# ROADS

AECOM

## Clem Jones Tunnel (CLEM7)

Brisbane, Australia

The AUD 3 billion Clem Jones Tunnel (CLEM7) is one of the largest road infrastructure projects ever undertaken in Australia. Project contractor Leighton Contractors and the Boulderstone Hornibrook Bilfinger Berger Joint Venture engaged AECOM and Parsons Brinckerhoff as lead designers. AECOM's challenge was to meet the stringent demands set by the project's fast-track construction approach, which saw design and construction occur simultaneously.

AECOM's innovative design work and efficient drawing management directly contributed to CLEM7's opening to traffic ahead of schedule. ProjectWise and ARENIUM replaced the previous design system to ensure that searches could be done quickly and accurately and eliminate the accidental use of outdated document revisions. As a result, team members contributed to a smooth transition from design to construction.



AECOM

## Gateway Upgrade Project

Brisbane, Australia

The AUD 2.12 billion Gateway Upgrade Project is one of the largest transportation infrastructure projects in Queensland's history. The Leighton Abigroup Joint Venture (LAJV) commissioned AECOM, in partnership with SMEC, for detailed design and construction-phase engineering of the project, which includes a new gateway bridge with pedestrian and cycle path, refurbishment of the existing bridge, and upgrade and extension of the existing gateway motorway.

AECOM and LAJV worked closely by using ProjectWise to connect team members in multiple countries, and completed an innovative design in just 15 months, enabling the bridge to open six months ahead of schedule. AECOM also designed 34 new or widened bridges, four new interchanges with enhanced entry and exit ramps, and 19 kilometers of new or upgraded road sections.





AECOM

**North Tarrant Expressway – Segment West**

Dallas/Fort Worth, Texas, United States

The North Tarrant Express (NTE) is a USD 2.5 billion, 13.5-mile project dedicated to improving mobility along the Airport Freeway corridor. Representing USD 1.6 billion of the project, the Segment West will reconstruct and upgrade existing lanes, improve and expand frontage lanes, and add managed toll lanes for commuters. NTE Mobility Partners contracted AECOM to complete the due diligence study that contributed to the consortium's winning bid.

With just five months to deliver the study, AECOM implemented ProjectWise to quickly and efficiently connect a 75-member team located in four offices. ProjectWise leveraged cloud computing to facilitate collaboration without the need for extensive IT infrastructure. By hosting the service in the cloud, AECOM saved four months in start-up time and 80 percent of on-site deployment costs.



AECOM

**SH 130 Segments 5 and 6**

Austin-San Antonio, Texas, United States

State Highway 130 parallels I-35 to relieve traffic in the Austin-San Antonio corridor. Central Texas Highway Constructors contracted AECOM to provide final plans, specifications, and estimates for the USD 1.35 billion Segments 5 and 6. This 27-mile stretch is a four-lane divided tollway with two multidirectional interchanges, 14 grade separations, and 31 miles of frontage road. Major design elements were due 18 months from notice to proceed with design-build.

From an on-site office, AECOM coordinated design among 120 employees spread across 20 offices throughout North America. ProjectWise connected 96 team members to the design process, enabling AECOM to integrate one approach to design and document versioning. ProjectWise saved the project more than USD 5.6 million in travel reduction and productivity gains, returning 80 times the original investment.



# ROADS

AECOM

## SH 161 Phase 4

Dallas, Texas, United States

The State Highway 161 Phase 4 project in the Dallas/Fort Worth metroplex is a four-lane, 6.5-mile tolled roadway with 45 bridges and two major interchanges. The USD 416 million project is the North Texas Tollway Authority's first design-build project. AECOM is the lead design team and subconsultant to the contractor. All major design elements had to be completed 15 months after notice to proceed.

Using ProjectWise for CAD file management, quality control, and document storage, AECOM coordinated 12 outside subconsultants and connected 210 users in 22 offices throughout the United States. With ProjectWise the company saved more than USD 838,000 in travel, review cycles, and document management and coordination costs, returning 22 times the original investment on this project alone.



2011 *BE INSPIRED* AWARD FINALIST

APIA XXI, S.A.

## Connecting Project Teams in Two Continents

Santander, Spain, and Texas, United States

Based in Spain, APIA XXI performs services in engineering, construction, technology, and development for the private and public sectors throughout Europe, Latin America, the Middle East, and North America. Working for U.S. departments of transportation (DOTs) proved challenging as each state used different CAD standards and design software. To partner with local consultants, the design team in Santander, Spain, needed new tools and workflows.

A USD 600 million roadway project for Texas DOT prompted APIA XXI to adopt GEOPAK, the agency's chosen design software. In addition, deploying ProjectWise eliminated problems with inconsistent standards, plan conflicts, and lost updates. With 62 engineers in Spain and 32 in Texas, APIA XXI has generated 4,000 plans and saved 6,000 man-hours on this one project.



2011 *BE INSPIRED* AWARD FINALIST



Requirement Management With ProjectWise Dependency Manager

Amersfoort, Netherlands

Although the A4 highway connects three of the four most important cities in the Netherlands, it is missing sections. In fact, a notorious 7,000-meter gap lies between Delft and Schiedam, which causes traffic jams on the adjacent A13 connecting the Hague and Rotterdam. ARCADIS created conceptual designs for the design and construction of the Delft/Schiedam link for the Dutch government.

The project teams used ProjectWise to collaborate and complete the environmental impact analysis in parallel, which enabled the team to save significant time finding, validating, and accessing project information. The new highway is the most environmentally friendly highway ever constructed in the Netherlands.

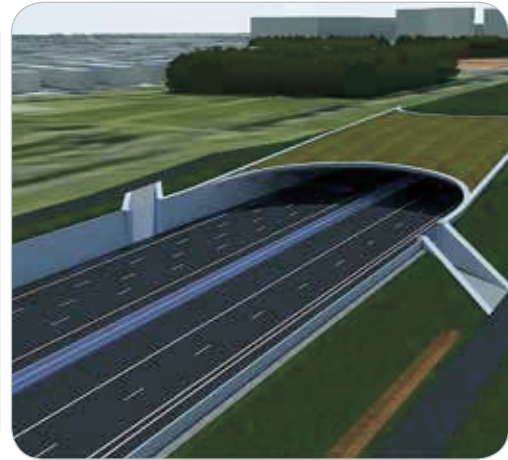
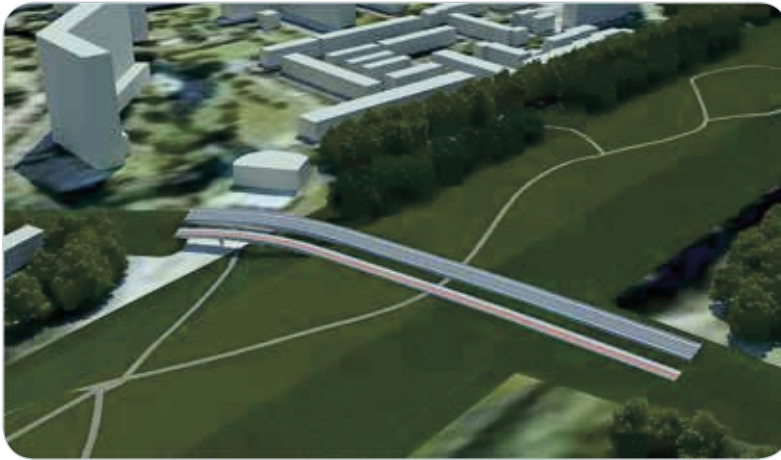

Hanson Professional Services Inc.

I-74 Mississippi River Crossing Corridor

Davenport, Iowa, and Moline, Illinois, United States

The USD 1.4 billion I-74 Mississippi River Crossing Corridor will connect Davenport, Iowa, and Moline, Ill. The project requires maintenance of traffic for 75,000 motorists while not only building new bridges, retaining walls, and ramps, but also demolishing old structures. Collaboration among the Iowa and Illinois departments of transportation, 10 consultants and 10 state and local agencies was facilitated by a web-based portal for sharing project documents.

In addition to MicroStation and GEOPAK, the firm used ProjectWise as the central storage system, which allowed more than 700 users in five states to access the 28,000 project documents. The portal enabled seamless communications among team members. As the area's traffic needs continue to grow, the I-74 Mississippi River Crossing Corridor will continue to improve traffic flow, mobility, and safety, and enhance economic development opportunities in the region.

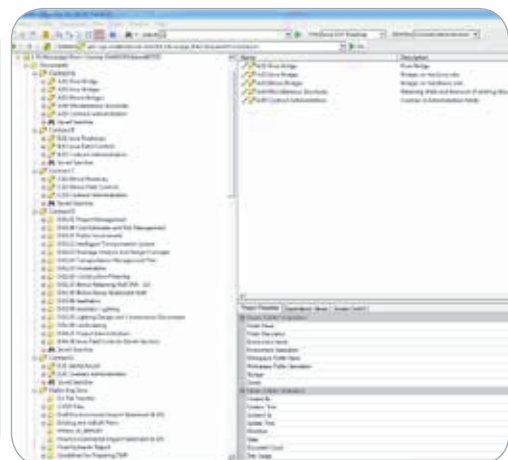
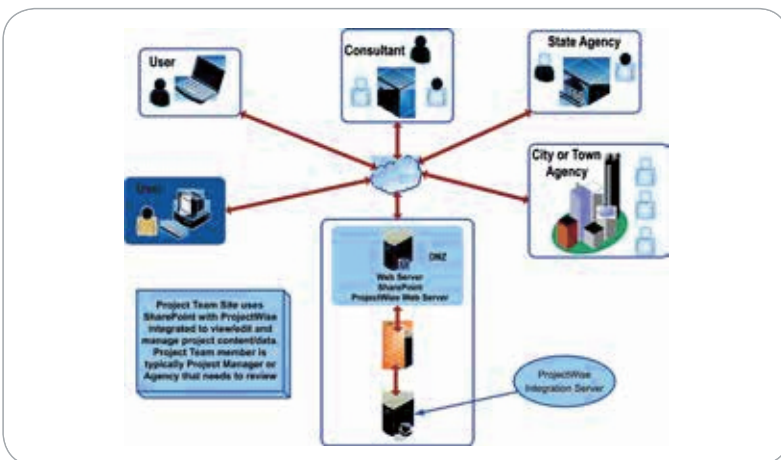



# ROADS

## Indiana Department of Transportation Indiana Department of Transportation ProjectWise Deployment Indianapolis, Indiana, United States

One unified workspace is part of the deployment of ProjectWise at the Indiana Department of Transportation (INDOT). Leaving the traditional network server has enabled the integration of all INDOT users into one environment for a more seamless sharing of data no matter where they are located or what type of work they are doing.

Time is better spent because there is an increased adherence to state standards, and control has been returned to the design engineers by removing the step of contacting the IT department to manage project rights. Four of the six district offices were initially ProjectWise users and the remaining deployments occurred later.

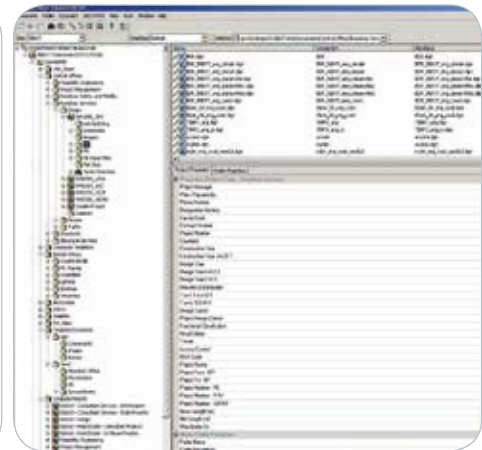
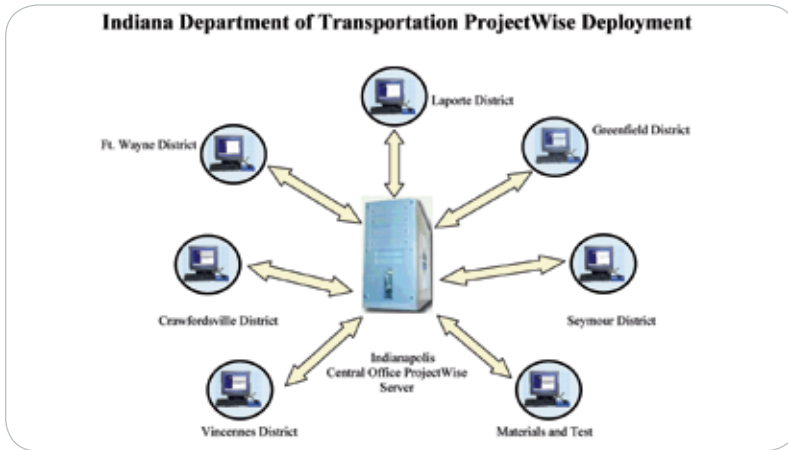

## Louisiana Department of Transportation and Development ProjectWise Custom PDF Publishing Baton Rouge, Louisiana, United States

The Louisiana Department of Transportation and Development automated PDF plan-set production for capital projects. The goals for the project were to improve quality by enforcing standards, simplifying plan creation, and enabling collaboration with outside contractors. Contractors now use the same process as the Louisiana Department of Transportation and Development, which ensures conformity and consistency.

The custom PDF publishing system was an enhancement to an existing ProjectWise system. Bentley helped develop a client/server-based solution that offers one configuration for internal employees and one for outside contractors. Plans now have the same index attributes as the originating design and plan locations and naming conventions are automated. Users are notified via email about PDF status.

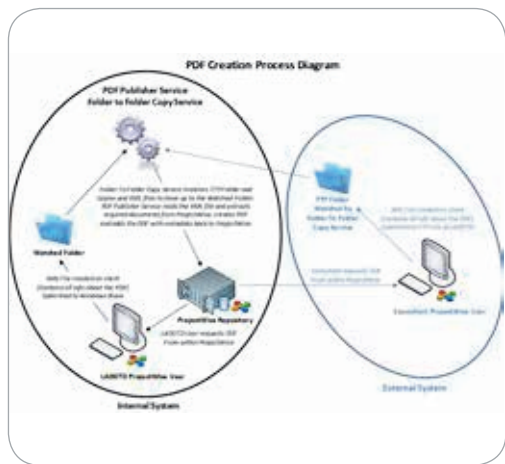
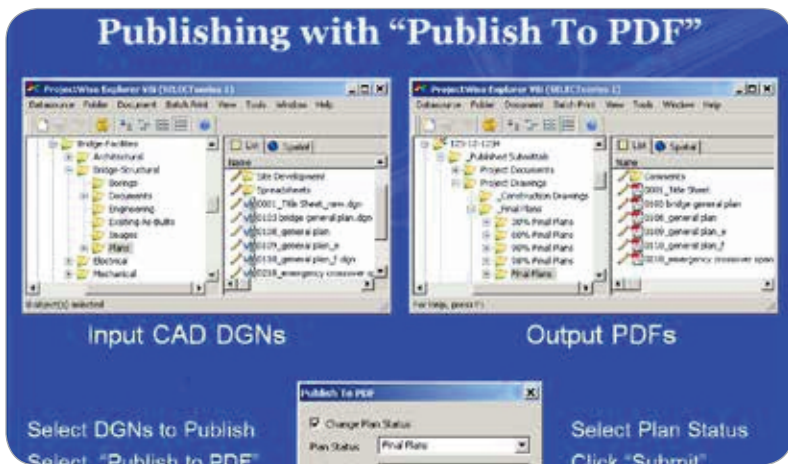

## Michael Baker Corporation Enterprise ProjectWise and the I-15 NOW Project Ogden, Utah, United States

This project encompasses 9.5 miles of interstate widening and reconstruction, including five interchanges, 24 bridges, and the widening of Interstate 15 by one lane in each direction. In addition to its highway and bridge design activities, Michael Baker Corporation is responsible for ensuring maintenance of traffic flow during the construction phase of the project.

The standard office configuration now includes ProjectWise, which connects project team members across Baker's 44 offices in the United States. By establishing an enterprise-level engineering content management environment, Baker has achieved faster file access, reduced rework, improved standards management, and created an integrated project framework for managing its portfolio of projects.



## Michigan Department of Transportation Michigan Runs on ProjectWise Lansing, Michigan, United States

The business objective for the Michigan Department of Transportation (MDOT) was to reduce paper processes, increase efficiencies, and add accountability to project teams. With 1.4 million documents, 320,000 folders, 186 document states, and 38 workflows, MDOT decided to run on ProjectWise. MDOT extended its use of ProjectWise outside of the CAD environment to save money and improve processes.

ProjectWise has allowed MDOT to develop low-cost IT solutions that would have previously been solved with custom-built software at a higher price. The workflows in place are saving an estimated USD 3 million per year in reduced travel, printing, scanning, mailing costs, and hands-on time. The audit trails have made staff accountable for tasks and provided the means to produce automated corporate measurements of critical processes.

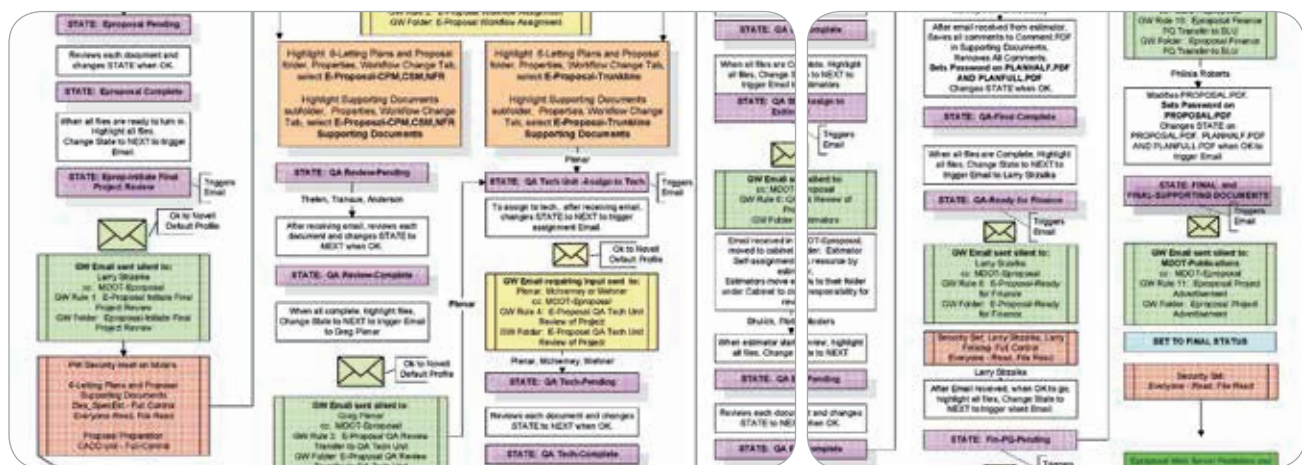

# ROADS

Missouri Department of Transportation

## An Electronic Workflow for Plan and Engineering Data Distribution

Jefferson City, Missouri, United States

The Missouri Department of Transportation (MoDOT) web-based bid letting system contains information about open and closed state highway lettings. The primary clients of the system are contractors interested in bidding on one or more upcoming projects. The previous bid letting process was slow and labor intensive because bids were all manually submitted by the contractors and manually entered into the system by MoDOT staff.

MoDOT's new ProjectWise-based system has enabled a fully electronic workflow; enhanced the timeliness and accuracy of bid letting information available on the web; increased the productivity of the MoDOT staff; eliminated contractor delivery service and travel expenses associated with manual bid submissions; and reduced clerical labor and errors associated with manual data entry.



Parsons Brinckerhoff and Arup JV

## Airport Link, Northern Busway (Windsor to Kedron) and Airport Roundabout Upgrade

Brisbane, Australia

Arup and Parsons Brinckerhoff formed the PBA Joint Venture to design Australia's largest transport infrastructure project – the AUD 5.6 billion Airport Link, Northern Busway (Windsor to Kedron) and Airport Roundabout Upgrade. Rapid mobilization of the project necessitated fast-track deployment of ProjectWise, which came online within three weeks of the project being awarded in 2008.

ProjectWise ultimately managed 1.5 million documents with 4.8 terabytes of data accessed by over 2,000 users in 40 global locations. The system saved time and costs in locating data (23,000 hours), controlling documents (USD 1 million), updating drawings (260 weeks), and traveling (USD 3.6 million). Other products utilized in the project included ProjectWise, MicroStation, MX, InRoads, gINT, and Structural Modeler.



2012 BE INSPIRED AWARD FINALIST AND SPECIAL RECOGNITION AWARD WINNER



Scott Wilson India Pvt Ltd  
**NH40 Re-engineering Designs**  
 Jorabat–Shillong, India

National Highway 40 from Jorabat to Shillong is a lifeline to India's northeastern states. To improve capacity and safety, the National Highway Authority upgraded the 31.7-kilometer, two-lane road to a dual two-lane controlled access tollway. Scott Wilson India developed detailed engineering designs, including highway alignment to a design speed of 50 kilometers per hour, nine bridges, 187 culverts, and one overpass.

Using MXROAD to design, visualize, and refine the alignment enabled consideration of multiple alternatives to avoid deep valleys and hillocks, and retain existing two-lane bridges in good condition. MXROAD also ensured design updates were reflected in final drawings and deliverables. The 3D capabilities reduced design cycle time by 40 percent. Collaboration through ProjectWise reduced errors, which saved 20 percent in construction costs.



Società di Progetto Brebemi S.p.A.  
**Brebemi: New Brescia-Bergamo-Milan Motorway Connection**  
 Brescia to Milan, Italy

The Brescia-Bergamo-Milan Motorway Connection is the new toll highway linking the city of Brescia with Milan. Its purpose is to ease congestion on the current road and motorway network along the corridor. The USD 2 billion project provides for the completion of the new motorway with three lanes in each direction, new local roads, and the renovation of existing roads.

The company selected ProjectWise to manage all project documentation. The benefits include time savings in communication, controlled access to design and procedure documents, and standardization of drawings and texts. The centralized server in Brescia houses all documentation for the final and executive plans – 60,000 technical drawings in editable and PDF format – which has been drawn up by external design units located throughout Italy.





# UTILITY TRANSMISSION AND DISTRIBUTION NETWORKS

Organizations that plan, design, build, and operate utilities continuously strive to increase productivity, automate engineering tasks, and deliver intelligent and highly accurate information models. The projects in this category exhibit best practices in the planning, engineering, and management of utility infrastructure.



# UTILITY TRANSMISSION AND DISTRIBUTION NETWORKS

Central Southern China Electric Power Design Institute

## Jiangxia 500 kV Transformer Substation

Wuhan, China

The USD 59 million Jiangxia 500 kilovolt transformer substation located in Wuhan, China, will improve the reliability of the load center's power supply, reduce power loss, and enhance the architecture of the regional grid network. The substation will also occupy less space, reduce electromagnetic interference, and adhere to green design initiatives.

The Central Southern China Electric Power Design Institute used 3D design for the first time on this project. Bentley Substation, Bentley Architecture, and GEOPAK were used to overcome the shortcomings of traditional 2D design. The tools helped optimize the size of the power distribution units to save space, and the collaborative design process using ProjectWise saved about 20 percent in design time.



2010 *BE INSPIRED* AWARD WINNER

Enogex LLC

## Implementation of AutoPLANT and ProjectWise

Western Oklahoma, United States

Enogex owns and operates more than 8,200 miles of pipe, seven processing plants, and 24 billion cubic feet of natural gas storage capacity in Oklahoma and Texas. In 2009, Enogex implemented AutoPLANT to standardize and reduce design and drafting time for gas gathering compressor stations. Within three years, the USD 10 million initiative reduced cycle time by 85 percent.

In 2009, average cycle time was 1,450 man-hours. Leveraging AutoPLANT reduced average cycle time to 220 man-hours in 2012. Subsequent integration with ProjectWise improved file organization, workflow, and information dissemination. As a result, project request delivery turnaround time was shortened from 16.4 workdays in 2010 to 11.65 workdays in 2012.

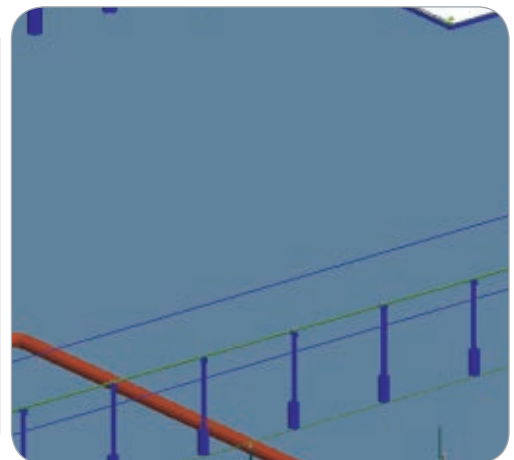
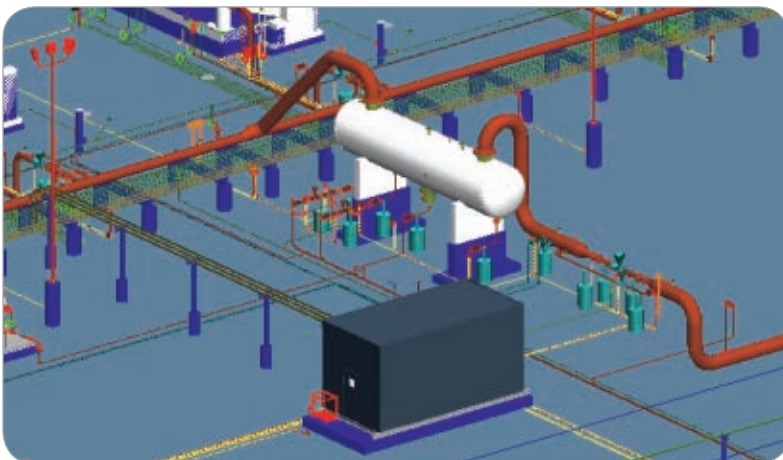

2012 *BE INSPIRED* AWARD WINNER

# UTILITY TRANSMISSION AND DISTRIBUTION NETWORKS

Hawaiian Electric Light Company

## The Advantages of a Managed Environment

Hilo, Hawaii, United States

Hilo-based Hawaiian Electric Light had previously used network drives for engineering information storage and retrieval, which had resulted in information being scattered throughout the organization with no document control or centralized access. Multiple versions of engineering drawings existed apart from the network, making it difficult to locate current versions and associated reference files. This had a major impact on productivity.

The company implemented ProjectWise Integration Server to provide more efficient engineering content management and improved information workflows. ProjectWise enables users to quickly locate pertinent project information including drawings, reference files, specs, and correspondences. Using ProjectWise, the team also identified inconsistencies in work processes, which will ultimately improve service delivery to electric customers.



Henan Electric Power Survey and Design Institute

## Henan 500-kilovolt Power Grid 3D Digitized and Integrated Operations Platform

Zhengzhou, China

The Henan Electric Power Survey and Design Institute unified management and operation of the 500 kilovolt power grid in China's Henan province through an integrated application for planning, design, construction, maintenance, and emergency and dispatch. 3D visualization of the grid included about 1,000 electrical design models in more than 200 categories as well as 800 structural, 100 building, and 400 overhead line structure models.

The company used MicroStation, Bentley Substation, GEOPAK, and Bentley PlantSpace to build an integrated model of the power grid incorporating data for 26 transformer substations, 96 transmission lines totaling more than 7,000 kilometers in length, and associated buildings and equipment. ProjectWise enabled collaboration among about 200 people and allied power companies, which reduced labor costs by USD 320,000 over the first two years.

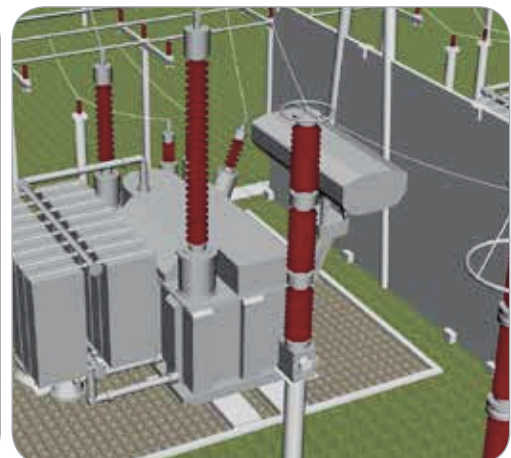

2012 BE INSPIRED AWARD FINALIST



# UTILITY TRANSMISSION AND DISTRIBUTION NETWORKS

## Huntsville Utilities

### An Integrated Implementation of ProjectWise, Expert Designer, and SAP

Huntsville, Alabama, United States

Huntsville Utilities implemented the Bentley utility solution in conjunction with a spatially enabled Oracle database to standardize processes and software across departments. As a result, the utility will be able to execute work orders, maintain permanent as-built records, and manage its assets more efficiently. In addition, an interface with a concurrent implementation of SAP Enterprise Asset Management will allow a common framework between the design and mapping processes and the asset management system.

The utility formed a cross-functional project team with Bentley Professional Services to configure software and convert data. The project included linking Oracle Spatial with Bentley's utility solution, integrating Bentley Expert Designer with ProjectWise, and interfacing these products with SAP. The utility will also use ProjectWise Geospatial Management to integrate with Oracle Spatial for tracking ongoing work in its service area.

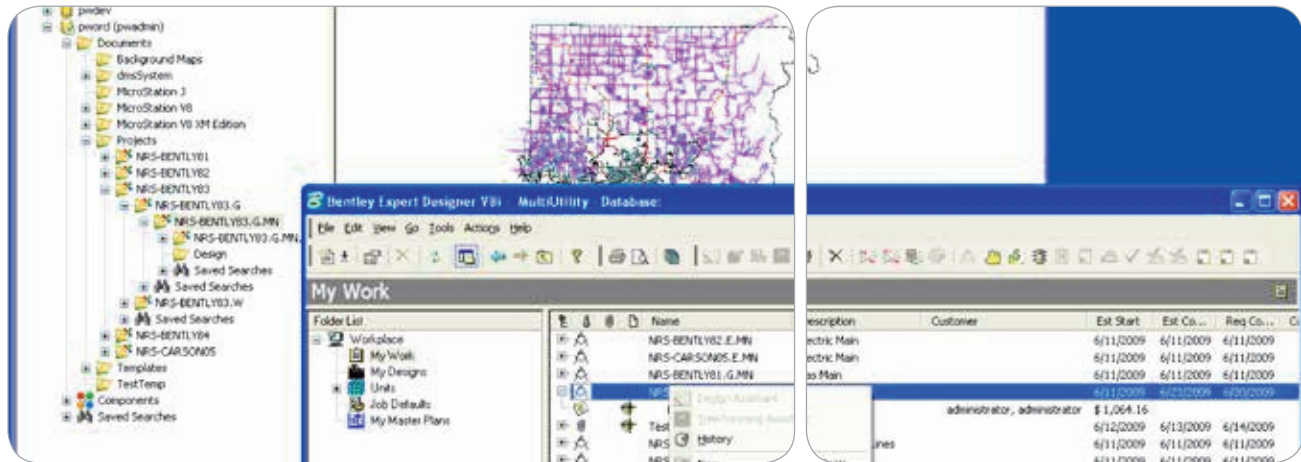

2009 *BE INSPIRED* AWARD WINNER

## Los Angeles Department of Water and Power

### LADWP ProjectWise Implementation

Los Angeles, California, United States

The Los Angeles Department of Water and Power (LADWP) maintained multiple drawing management systems, including file storage on Windows servers and drawing data and historical information in Oracle databases, along with Linux-based file security and a Visual Basic drawing number generator. LADWP chose ProjectWise to replace the multiple homegrown systems.

The implementation project involved integrating legacy information and merging hundreds of thousands of files in various formats into one system. LADWP used the ProjectWise Software Development Kit to customize the system in house. Implementing ProjectWise has reduced the time spent searching for files in half, cut plotting time by 40 percent, and eliminated the need for a dedicated resource to maintain and support the legacy systems.

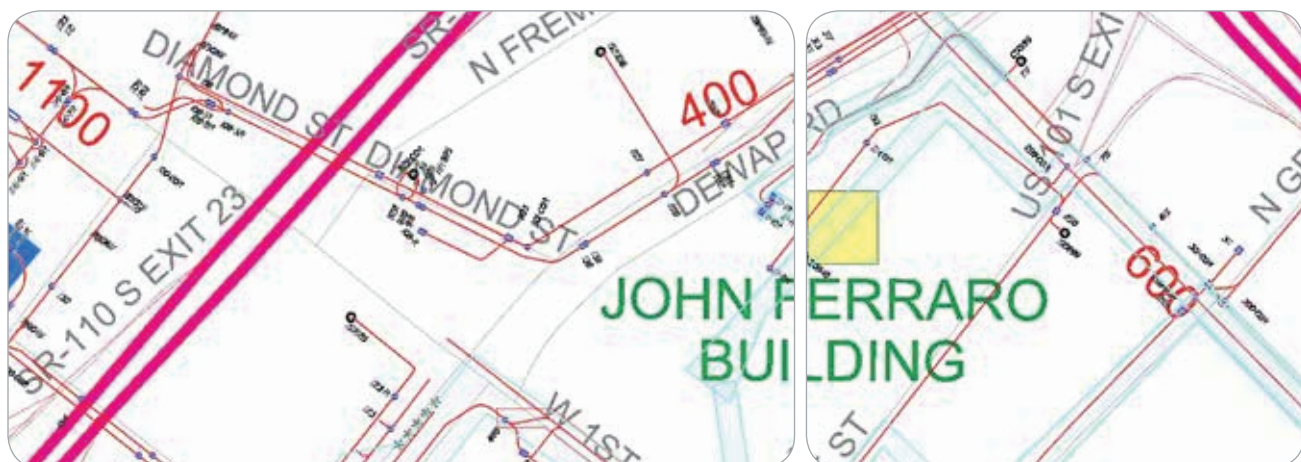

2011 *BE INSPIRED* AWARD WINNER



# UTILITY TRANSMISSION AND DISTRIBUTION NETWORKS

Powercor Australia  
ProjectWise GIS Link  
Melbourne, Australia

CitiPower and Powercor Australia are electricity distributors serving Melbourne, central Victoria, and western Victoria. When their existing drawing management systems (DMS) became outdated, the companies replaced them with ProjectWise. The conversion involved training more than 600 personnel, migrating more than 450,000 drawings, generating PDFs from all drawings, and integrating ProjectWise with the existing GIS.

ProjectWise was customized to accommodate CitiPower/Powercor workflows. File migration was simple, and the DMS-GIS integration enabled users to easily retrieve plans and, under fault conditions, quickly get customers back online. The ProjectWise implementation saved about USD 75,000 per year in maintenance and subscription costs.

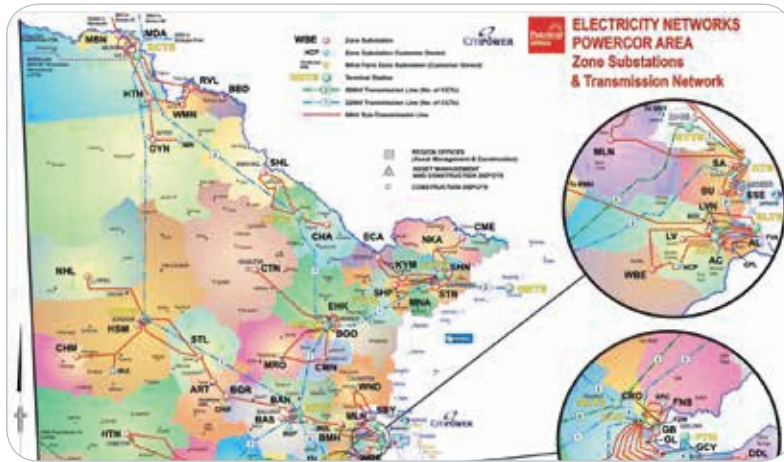

## Saudi Electricity Company/Implemented by Nahil Computer Company Establishment of Kingdom-wide EDMS at SEC All Regions, Saudi Arabia

Saudi Electricity Company was established in 2000 with the merger of dozens of electricity producers throughout Saudi Arabia. At a cost of USD 2 million over 12 years, eight subprojects consolidated and standardized Saudi Electricity's information infrastructure in an enterprise-level engineering document management system (EDMS) based on ProjectWise.

ProjectWise enabled Saudi Electricity to support high availability, load balancing, distributed processing, and open standards, which allows integration with other enterprise systems. Nahil provided the software, implementation, training, support, and backlog conversion and migration of all technical documentation into the EDMS. Nahil is also the Bentley SELECT support partner providing kingdom-wide support.

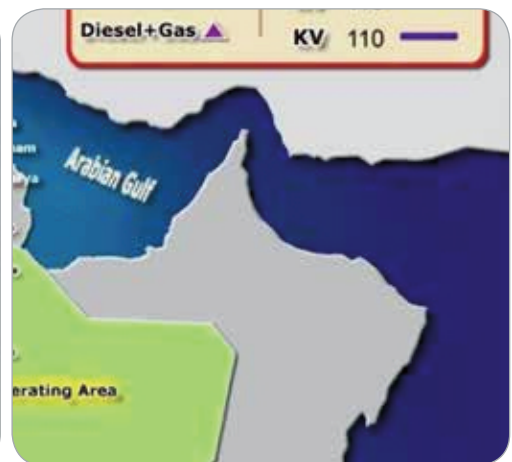
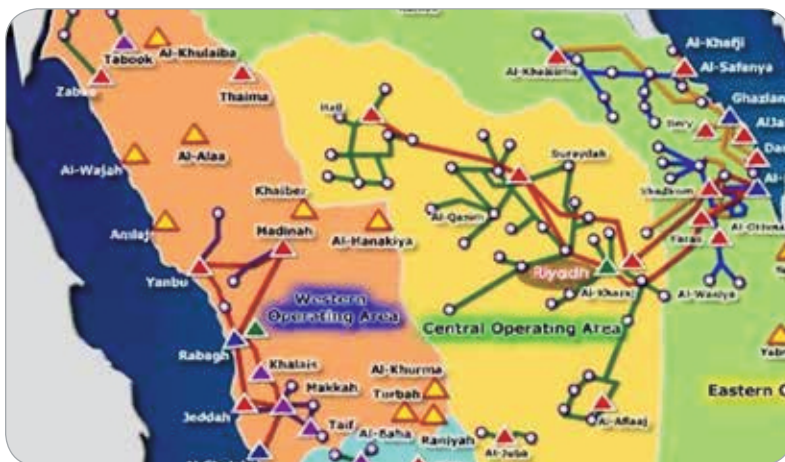

2012 BE INSPIRED AWARD WINNER

# UTILITY TRANSMISSION AND DISTRIBUTION NETWORKS

swb Netze GmbH & Co. KG

## Sharing GIS Information With Contractors: Utilities Infrastructure Portal (OPA)

Bremen, Germany

Each year, swb Netze receives 9,000 enquiries concerning line information in Bremen, Germany. Previously, enquiries were processed during network operator service hours. To reduce staff time commitment, swb Netze implemented the Utilities Infrastructure Portal (OPA), which is available 24/7. OPA is also used internally for the digital provision of plans and as-builts.

At the core of OPA, Bentley Geo Web Publisher and ProjectWise provide a web front end from which registered users can request maps for heating, gas, water, and electricity in specific regions. Because OPA administers about 90,000 documents, the automation of these processes enables swb Netze to reduce costs by approximately 75 percent for an annual savings of EUR 300,000.

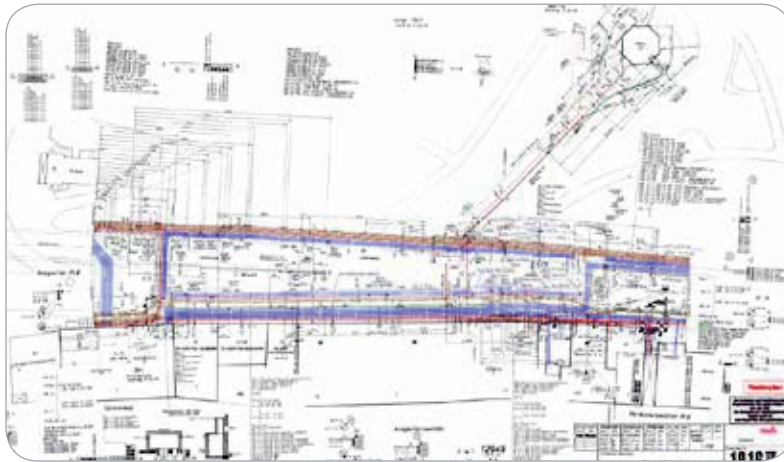

Xcel Energy

## ProjectWise Optimized for Electric Utilities

Minneapolis, Minnesota, United States

Operating in eight Western and Midwestern states, Xcel Energy provides energy-related products and services to 3.4 million electricity customers and 1.9 million natural gas customers. Xcel undertook a USD 1 million project to manage and share engineering content with its widely distributed workforce.

ProjectWise was integrated with all regional logic and back-office systems and then deployed in all of Xcel's operating regions. ProjectWise Software Development Kit resources were used to create unique business requirements and other custom configurations to support federal compliance mandates. The technology allows Xcel to centrally locate all engineering content and distribute to project participants as needed wherever they are.

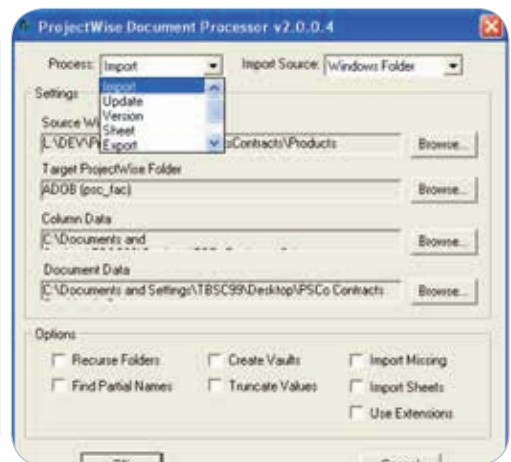
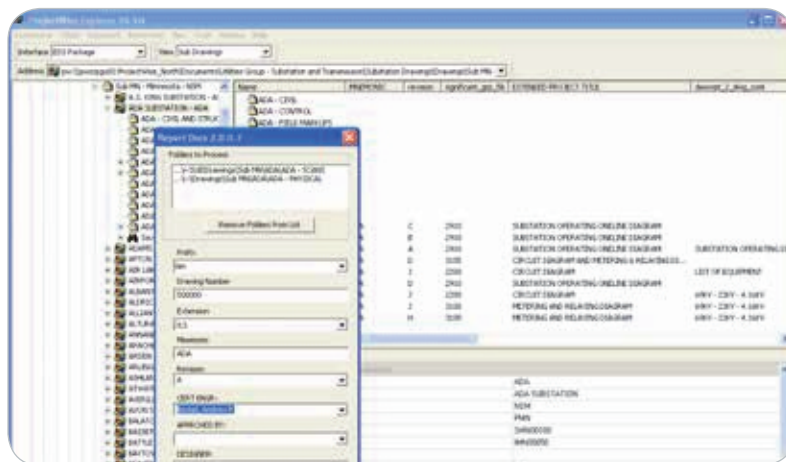

# UTILITY TRANSMISSION AND DISTRIBUTION NETWORKS

TRC Companies, Inc.

TRC Document Management System

Augusta, Maine, United States

When TRC's power delivery engineering group experienced rapid growth through acquisitions and new hires, the company was unable to efficiently share resources among offices. As a result, resources were underutilized in some offices and unavailable in others. ProjectWise was chosen to connect offices from Maine to California. With the use of consistent file structure, collaboration is enhanced and information is instantly available.

ProjectWise currently has more than 700 users and manages more than 1.2 million files totaling 1.5 terabytes of data. TRC uses ProjectWise to access information for all phases of a project, from proposal to project archive, and every department uses the system. Since TRC adopted ProjectWise, collaboration among offices has increased, file management time has decreased, and confidence that information is correct is unquestioned.

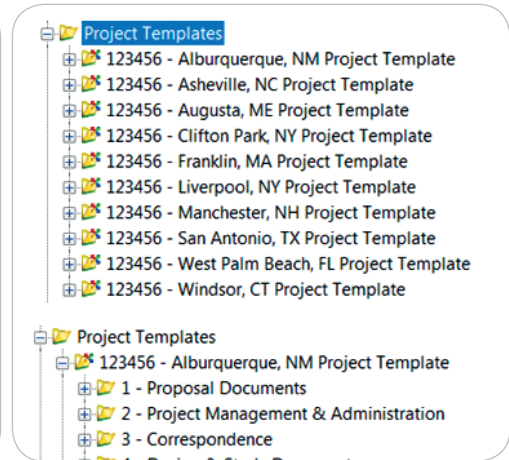
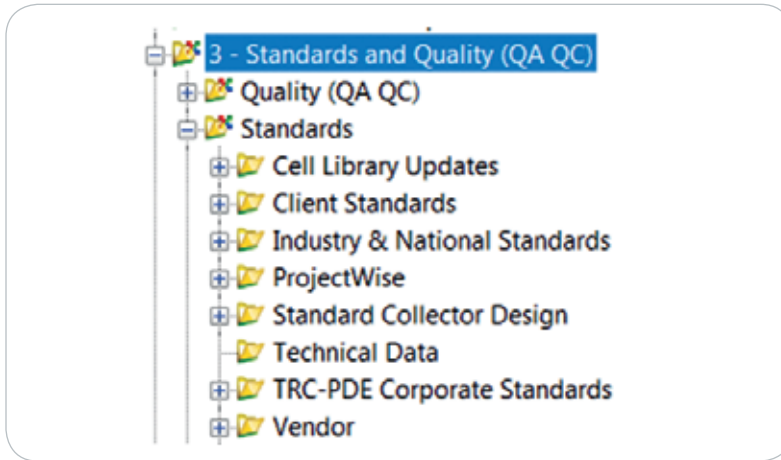





# WATER AND WASTEWATER

Common goals of water resource professionals include increasing efficiencies in engineering processes while minimizing environmental consequences, preserving public capital investment, and enhancing the level of service of costly but necessary water infrastructure. This category features projects that demonstrate the innovative use of technology to plan, design, manage, model, and construct water and wastewater treatment plants.

# WATER AND WASTEWATER

Carollo Engineers

## City of Phoenix 24th Street Water Treatment Plant

Phoenix, Arizona, United States

To control the formation of disinfection by-products in a potable water distribution system, the city of Phoenix, Ariz., implemented an innovative 3D design for a USD 65 million, 120 mgd granular activated carbon post-filter contactor facility. Efficient interaction between the city and contractor using 3D models visualized the intricate design, accommodated plant operator needs, and minimized and resolved conflicts between various elements within the contactor pipe gallery.

Weekly team meetings – using ProjectWise to share files and submit drawings – facilitated coordination among the prime consultant and two major subconsultants. The enhanced design process using MicroStation, PlantSpace, and STAAD.Pro allowed the city to improve water quality for customers within budget while making the project up to 25 percent more profitable for the contractor.

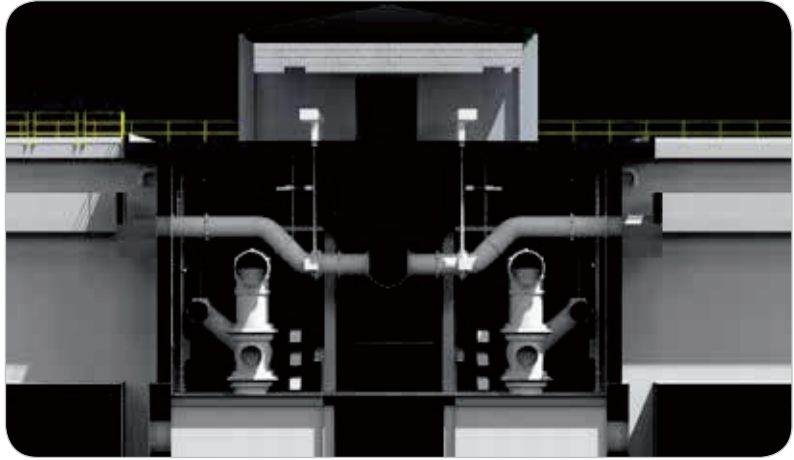
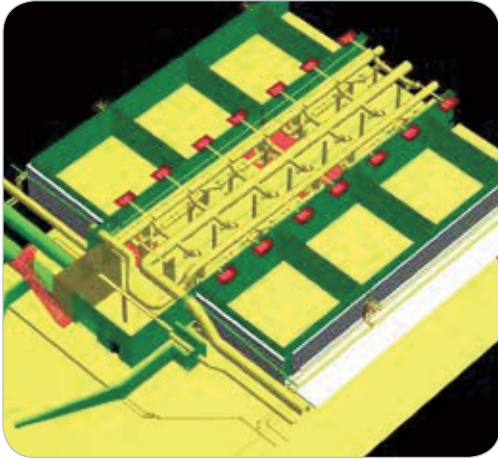

Carollo Engineers, Inc.

## South Secondary Improvements Project

Denver, Colorado, United States

The Metro Wastewater Reclamation District in Denver, Colo., is modifying and upgrading the South Secondary Treatment facilities to treat 114 million gallons of wastewater per day. The USD 136 million project had to be completed within the state-mandated compliance schedule, requiring the contractor to place approximately 75,000 cubic yards of concrete and install the major electrical, mechanical, and instrumentation equipment in the first 2.5 years.

As design engineer and owner's representative, Carollo Engineers used MicroStation, Bentley Navigator, ProjectWise, and InRoads to link 12,154 activities from the contractor's Primavera P6 baseline schedule with the 3D model to create a 4D visualization. The detailed 4D model aided the project team in evaluating whether the accelerated schedule was achievable. Proactive coordination resulted in 20 days of float ahead of the early completion date.

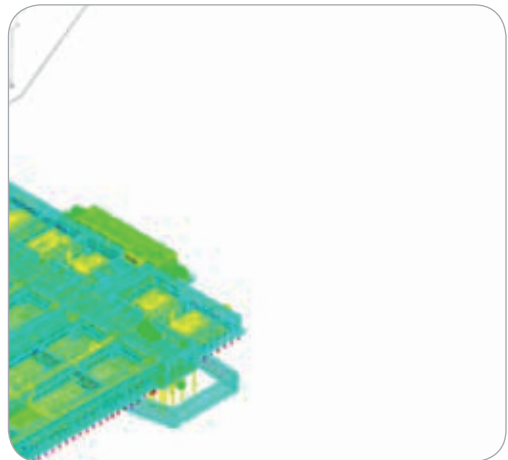
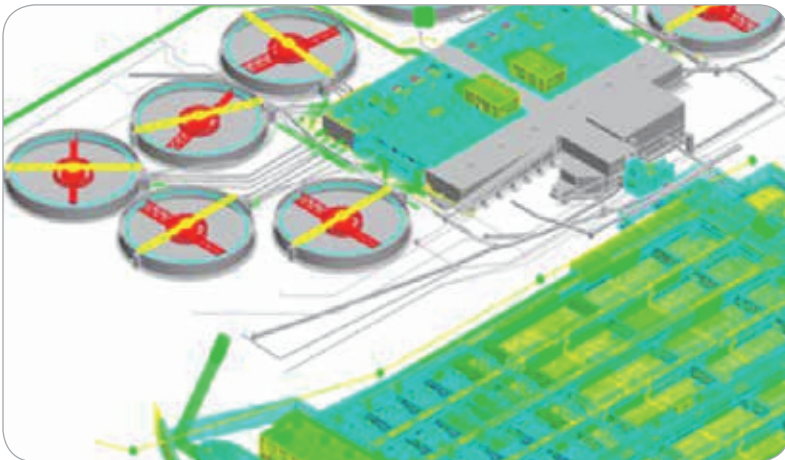

2012 BE INSPIRED AWARD WINNER



# WATER AND WASTEWATER

Camp Dresser and McKee, Inc.

## CDM Arbennie Pritchett Water Reclamation Facility

Fort Walton Beach, Florida, United States

Okaloosa County teamed with Camp Dresser and McKee (CDM) to design and build a state-of-the-art wastewater treatment facility. The Arbennie Pritchett water reclamation facility will serve a population of 181,000 in the Florida panhandle, treating 10 million gallons of wastewater per day to the stringent Florida Department of Environmental Protection standards. The high-quality effluent will be discharged to rapid infiltration basins for groundwater recharge, reclaiming a valuable water resource.

The facility was designed using intelligent 3D across all disciplines for more than 20 buildings and structures. The program called for alternative, design-build delivery to meet an aggressive schedule. Final design had to be completed within 5.5 months of notice to proceed. To meet this short timeframe, the team needed to be able to quickly visualize the facility to agree on the form and function of the elements early in the design process.

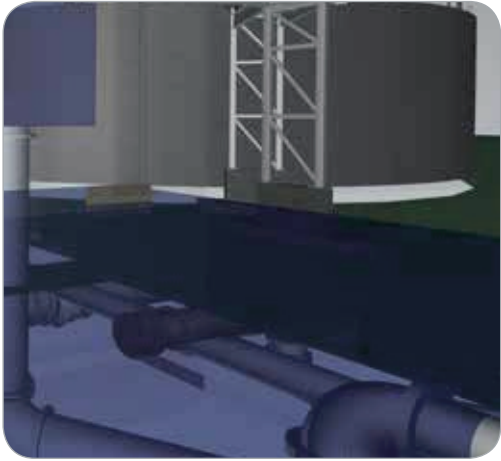
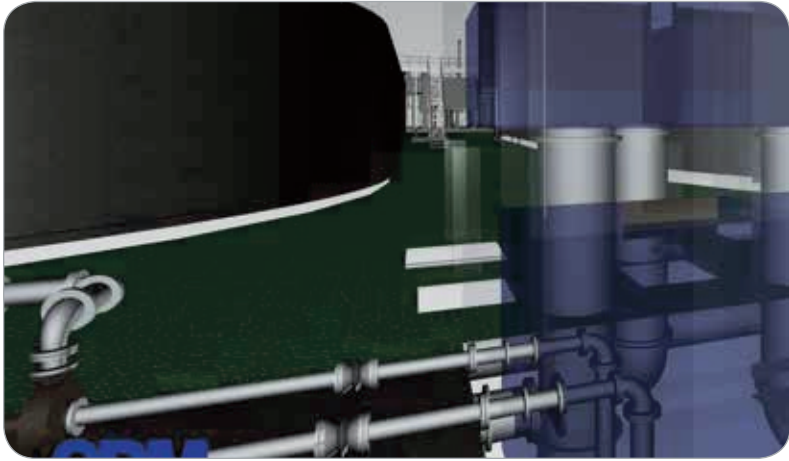

2008 BE INSPIRED AWARD WINNER

CH2M HILL

## PWB Bull Run Supply Treatment

Portland, Oregon, United States

Portland Water Bureau's USD 100 million treatment plant is located on a constrained site on Bull Run River in Oregon. With both MicroStation and AutoCAD applications in use throughout multiple internal offices and 28 external entities, CH2M HILL monitored consistent implementation of the project-specific standards built into each platform. Modeling datasets were also provided to building, plant, and civil disciplines.

ProjectWise caching servers connected CH2M HILL's offices over its wide area network, while ProjectWise Gateway Service and ProjectWise Web Servers connected external users. Using ProjectWise reduced ramp-up time from one week to eight hours per entity and saved eight hours per week with automated reference file management/data synchronization.

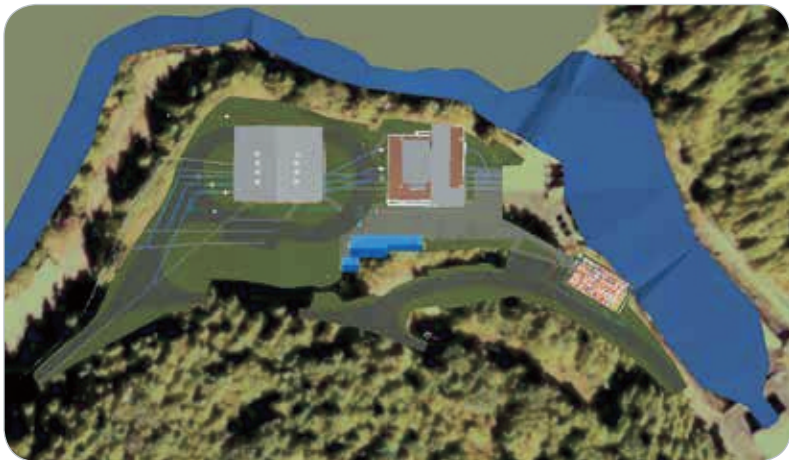

# WATER AND WASTEWATER

Philadelphia Water Department

## ProjectWise Deployment

Philadelphia, Pennsylvania, United States

The Philadelphia Water Department designs and manages a USD 50 million annual capital improvement program. Project information was scattered, however, with CAD files on one server, specifications on another, paper folders in various places, and documents saved on individual hard drives. The department had a project management system that tied into the as-built document management system, but it needed one integrated engineering content management system.

ProjectWise provided the solution without replicating data. When a ProjectWise folder is created, project metadata is pulled from the project management system and incorporated in the project folder. Links to and from the project management system enable users to retrieve data from either location. A street centerline-based system, the document management system has an interface that allows users to search for projects geospatially. As a result, project-specific content is accessible from any system.

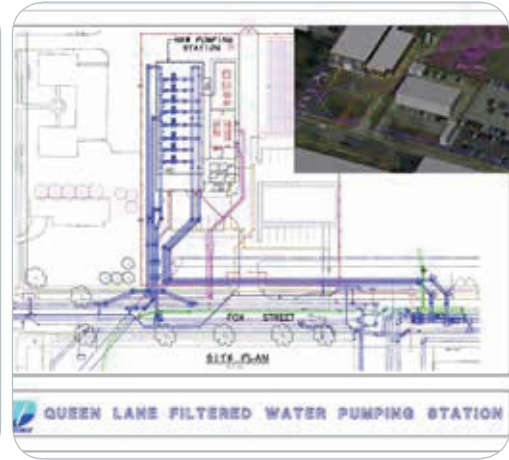

## SEBES

### Collaboration in Drinking Water Distribution

Esch-sur-Sûre, Luxembourg

As the main drinking water producer in Luxembourg, SEBES collects, stores, controls, and distributes water to major clients and subdistributors. The company undertook a global integration, communications, and traceability project to respond to concerns about archiving, retrieving, accessing, and sharing data. Capital costs were USD 70,000.

A ProjectWise installation implemented the functionality required to fulfill the specifications set up by the dedicated team. ProjectWise Integration Server provided scalable, standards-based data warehouse functionality. Teams of supervising staff, technical development, maintenance, chemical laboratory, and land surveying now collaborate through one central server installation.



Sewage Systems Office, Public Works Department, Taipei Municipal Government  
**Sewage Treatment Plant 3D Equipment Deployment and Management**  
Taiwan, China

Stormwater emergency response in Taipei, Taiwan, was hampered by the unavailability of real-time data on rainfall, water levels, sluice conditions, and pumping station equipment operation. The Sewage Systems Office of the Taipei Municipal Government Public Works Department built a 3D management and disaster warning system to support operations during flood season.

The initiative began with a USD 100,000 pilot project at Dihua Pumping Station. The Sewage Systems Office used MicroStation to provide a 3D model with graphic monitoring modules and ProjectWise to make the system accessible to multiple monitoring and maintenance sites. External data such as rainfall and water levels were also integrated into the model.

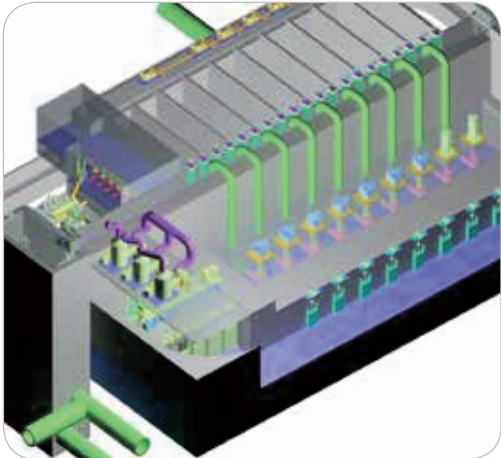
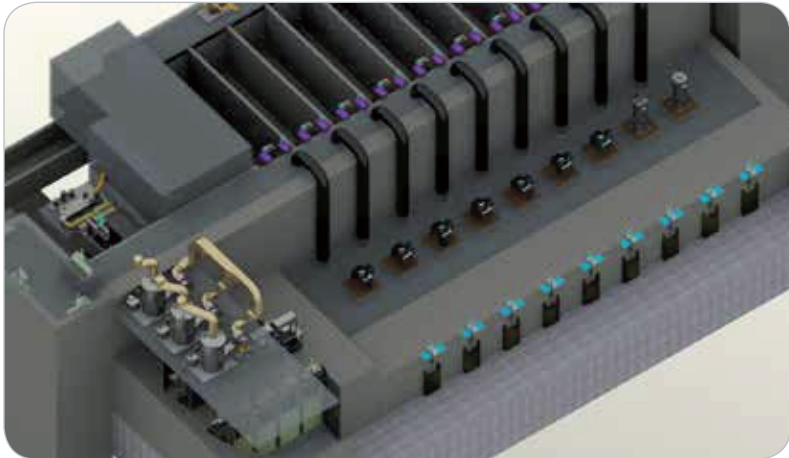



# INDEX

	ORGANIZATION NAME	PROJECT NAME	PAGE
	AECOM	Clem Jones Tunnel (CLEM7)	56
	AECOM	Gateway Upgrade Project	56
	AECOM	North Tarrant Expressway – Segment West	57
	AECOM	SH 130 Segments 5 and 6	57
F	AECOM	SH 161 Phase 4	58
	Al Futtaim Carillion	MotorCity Uptown Area II Buildings	4
	AMCDE	Khursaniyah, Qatif, and Manifa Water Injection System	34
	Anglo American plc	Geospatial Integration Project	26
F	APIA XXI, S.A.	Connecting Project Teams in Two Continents	58
	ARCADIS	Requirement Management With ProjectWise Dependency Manager	59
	Aurecon Hatch	Collaboration Using Bentley Navigator	26
	Barclays Bank PLC	Space Asset Capture and Branch on a Page	4
	Bharat Oman Refineries Limited	ProjectWise Implementation at BORL Refinery	44
	Camargo Corrêa	Comperj Petrochemical Plant	38
	Camargo Corrêa	Jirau Hydropower Plant	44
	Camargo Corrêa/CNEC Engenharia	Serra do Facao Hydroelectric Power Plant	38
	Carollo Engineers	City of Phoenix 24th Street Water Treatment Plants	74
W	Carollo Engineers	South Secondary Improvements Project	74
W	Camp Dresser and McKee, Inc.	Arbennie Prtichett Water Reclamation Facility	75
W	Central Southern China Electric Power Design Institute	Jiangxia 500 kV Transformer Substation	66
W	CH2M HILL	Phase 1 – O'Hare Modernization Program	10
	CH2M HILL	PWB Bull Run Supply Treatment	75
	China Huanqiu Contracting & Engineering Corp.	Establishing a Collaborative Content Management Platform	14
	China Nerin Engineering Co., Ltd.	Tongling Nonferrous Metals Copper Smelting Project	27
	China Petroleum Engineering & Construction Corp. East-China Design Institute	CNPCCEI Collaborative Management	34
F	CNGS Engineering	Ice-resistant Offshore Platform LSP-1	30
F	CNGS Engineering	LAM-B Wellhead Platform	30
	Continuus-Properzi S.p.A.	Engineering Collaboration Using ProjectWise	45
W	Crossrail Limited	Crossrail	22
	Dillard's	Dillard's Store Planning Application	5
	Dockwise Ltd.	Inconceivable Transports	31
	DP Architects Pte Ltd	ProjectWise Distributed Design Management	5
	DPR Construction	Arizona State University New Business School	18
	DPR Construction	ProjectWise Implementation	14
	DPR Construction	UCSF Medical Center	6
	Energoprojekt Gliwice SA	Gas-Fired CHPP Glogow and Polkowice	39
F	Engevix Engenharia S.A.	Cacu Hydroelectric Power Plant	39
W	Enogex LLC	Implementation of AutoPLANT and ProjectWise	66
F	Eskom	Integrated Engineering Management System for Eskom Lethabo Power Station	40
F	Fluor/HDR Global Design Consultants	RTD FasTracks Eagle P3 Project	50
W	Gautrain	Gautrain Rapid Rail Link	50
	GE Water & Process Technologies	Automated Drawing Release Using ProjectWise	45
	GEA Process Engineering France	Engineering Collaboration Using ProjectWise	46

	ORGANIZATION NAME	PROJECT NAME	PAGE
	Gemeente Utrecht/POS	Redevelopment Station Area Utrecht – A Complete Makeover	51
	GHAFARI Associates, LLC	Sutter Health Eden Medical Center	6
W	Giprotyumenneftegaz	Booster Pump Station With Preliminary Water Discharge Facility	35
	Guangdong Highway Design Institute Co., Ltd.	ProjectWise Application in Humen Project	15
F	Hanson Professional Services Inc.	I-74 Mississippi River Crossing Corridor	59
	Hatch Associates, Limited	Coal Preparation Plant Raw Coal and Reliability Improvement Project	46
	Hawaiian Electric Light Company	The Advantages of a Managed Environment	67
F	Henan Electric Power Survey and Design Institute	Henan 500-kilovolt Power Grid 3D Digitized and Integrated Operations Platform	67
F	HNTB Corporation	Firm-wide Design-build Quality Plan	18
W	Huntsville Utilities	An Integrated Implementation of ProjectWise, Expert Designer, and SAP	68
F	HydroChina Zhongnan Engineering Corporation	Tuoba Hydro-Power Station	40
	IDM E&C	Four Major Rivers Restoration Project	19
	Indiana Department of Transportation	ProjectWise Deployment	60
	Infotech Enterprises Ltd	Railway Signaling Design	51
	Korea District Heating Engineering Co., Ltd	Paju Combined Heat and Power Plant	41
	Larsen & Toubro Limited	Motor Spirit Quality Upgrade	47
	Leningrad Nuclear Power Plant	Decommissioning Database of Leningrad Nuclear Power Plant	41
W	Los Angeles Department of Water and Power	LADWP ProjectWise Implementation	68
	Louisiana Department of Transportation and Development	ProjectWise Custom PDF Publishing	60
	Maryland State Highway Administration	2011-2012 Maryland Official Highway Map	22
	MECON Limited	Wire Rod Mill	27
	Michael Baker Corporation	Enterprise ProjectWise and the I-15 NOW Project	61
	Michigan Department of Transportation	Michigan Runs on ProjectWise	61
	Missouri Department of Transportation	An Electric Workflow for Plan and Engineering Data Distribution	62
	MMX Mineracao e Metalicos S.A.	Sistema MMX Minas-Rio	28
	Moh and Associates, Inc.	Collaboration and Integration of ProjectWise	7
	Mott MacDonald Limited	How ProjectWise Is Providing Global Collaboration as an Enterprise Solution	15
	MTR Corporation Limited	ProjectWise for Railway Business	52
	Network Rail	Design to Cost Standard Design Catalogue	52
F	Oakridge National Laboratory – Facilities Development Division	Sustainability in Information Management Through CIM	10
	Ona Architecture	Continuum Project	7
	Ove Arup & Partners	Augmented Reality for Fulton Street Transit Center	53
	Parsons Brinckerhoff	ProjectWise Automated PDF Generator	16
SR	F Parsons Brinckerhoff and Arup JV	Airport Link, Northern Busway (Windsor to Kedron) and Airport Roundabout Upgrade	62
	PechorNIPIneft	Construction of Booster Oil-refining Station on Bayanduskoe Oil Field	35
	Petrofac Brownfield	Documentation Management Systems Upgrade	36
	Philadelphia Water Department	ProjectWise Deployment	76
	PKP Polskie Linie Kolejowe S.A.	Information System for Railway Lines (SILK)	53
W	Port of Helsinki	Vuosaari Harbour Maintenance System	23
	Powercor Australia	ProjectWise GIS Link	69
W	Saudi Electricity Company/Implemented by Nahil Computer Company	Establishment of Kingdom-wide EDMS at SEC	69
	Scott Wilson India Pvt Ltd	NH40 Re-engineering Designs	63
	SEBES	Collaboration in Drinking Water Distribution	76

# INDEX

	ORGANIZATION NAME	PROJECT NAME	PAGE
	Sewage Systems Office, Public Works Department, Taipei Municipal Government	Sewage Treatment Plant 3D Equipment Deployment and Management	77
F	Shawmut Design and Construction	Dudley Square Municipal Building	19
	SNC-Lavalin Australia Pty Ltd.	Visualization: A Leap of Faith	16
	Societa di Progetto Brebemi S.p.A.	Brebemi: New Brescia-Bergamo-Milan Motorway Connection	63
	swb Netze GmbH & Co KG	Sharing GIS Information With Contractors: Utilities Infrastructure Portal (OPA)	70
	Sydney Airport Cooperation Limited	Enterprise Engineering Document Management Project	11
	Tessenderlo Group	MOC in 3D PDF Is Top	47
	Tetra Tech, Inc.	Elliott Bay Seawall Project	23
	Toyo Engineering India Limited	Enhancing Project Delivery Using ProjectWise	48
	TRC Companies, Inc.	TRC Document Management System	71
	Turkish Hard Coal Mining Authority	Gas Tracing at -1,000 Meters With Bentley Geo Web Publisher	28
	U.S. Army Garrison Bamberg	ProjectWise and MicroStation Deployment	11
F	URS/Scott Wilson	Crossrail Farringdon Station	54
F	URS/Scott Wilson	East London Line	54
F	USACE Portland District	Cougar Dam and Reservoir Adult Fish Collection Facility	24
	Ville de Grenoble	ProjectWise Interoperable Real Estate Municipal Database	24
	Volkswagen of Brasil	New Painting Building Facility	8
	Xcel Energy	ProjectWise Optimized for Electric Utilities	70







Recognizing the critical importance of being a good corporate citizen, Bentley is uncompromisingly committed to supporting ecological sustainability. This support goes beyond the stewardship of environmental resources to include investment in strategic educational and training initiatives that foster a workforce of skilled infrastructure professionals capable of meeting the world's growing sustainability challenges.

*The ProjectWise Project Showcase* is one small example of Bentley's commitment to promoting sustainable development through its business practices. As part of this effort, this publication has been printed on Forest Stewardship Council (FSC) certified paper, which identifies products that contain wood fiber from well-managed forests.



Lined writing area consisting of 26 horizontal lines.



[www.bentley.com](http://www.bentley.com)

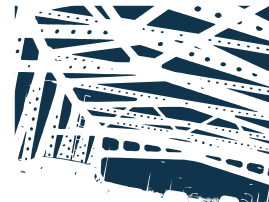
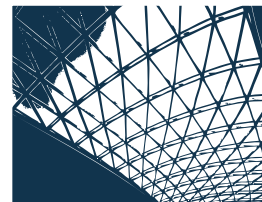
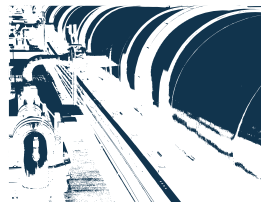
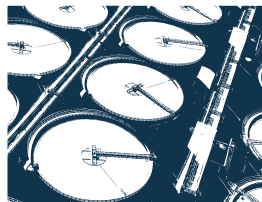
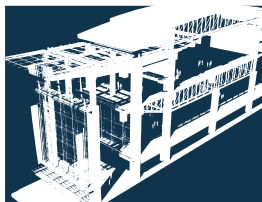
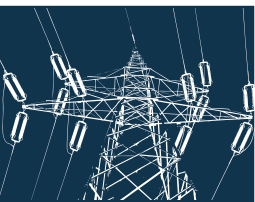

## Corporate Headquarters

685 Stockton Drive • Exton, PA 19341 • United States  
1-800-BENTLEY (1-800-236-8539) • Outside the United States +1 610-458-5000

## Bentley EMEA

2nd Floor • Block 2, Park Place • Upper Hatch Street • Dublin 2 • Ireland • +353 1 436 4600

## Bentley Asia

Unit 1402-06, Tower 1 • China Central Place, Beijing 100025 • China • +86 10 5929 7000

