

THE AUTOPIPE PROJECT SHOWCASE

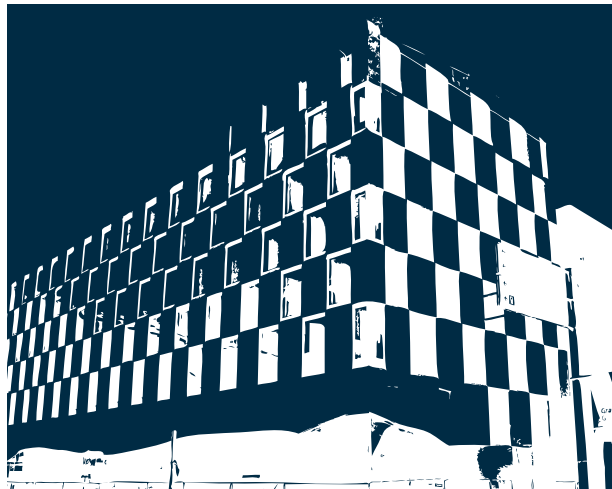

Extraordinary Infrastructure of the *Be Inspired* Awards

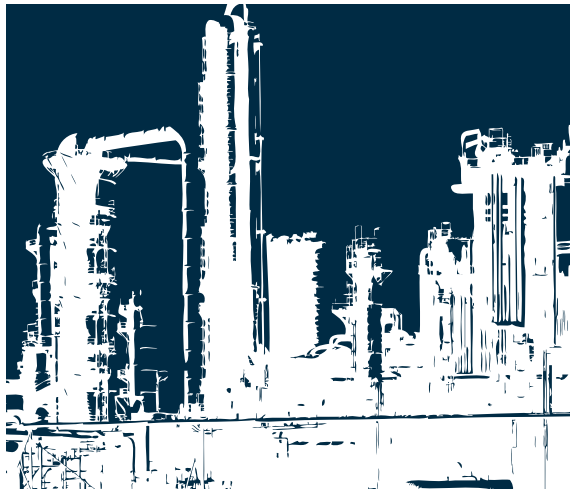

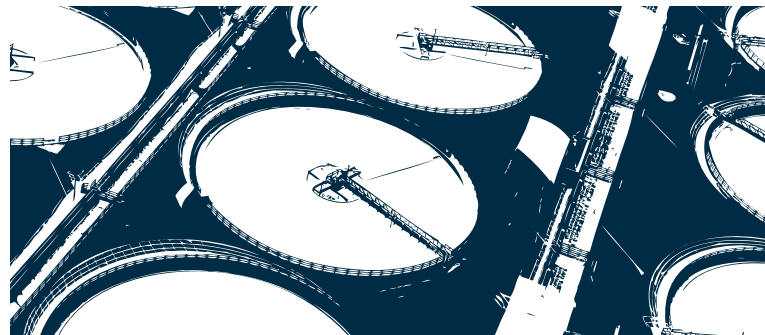
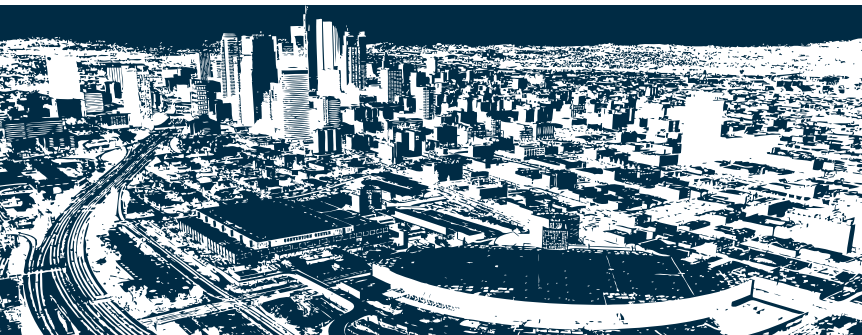
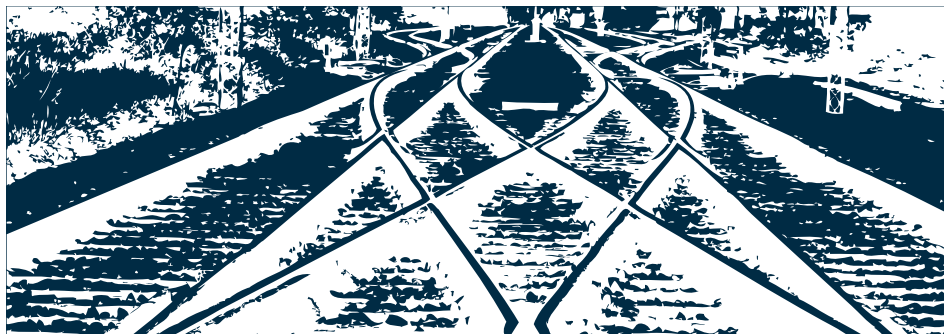

Bentley's mission is to provide innovative software and services for the enterprises and professionals who design, build, and operate the world's infrastructure – sustaining the global economy and environment for improved quality of life.

The AutoPIPE Project Showcase and *The Year in Infrastructure* series of publications are project yearbooks published by Bentley Systems, Incorporated that showcase the extraordinary work of Bentley users sustaining the world's infrastructure.

For information about how to enter your innovative project for consideration in the next *Be Inspired Awards* competition or for additional information about this program, visit www.bentley.com/beinspired.

ONLINE VERSIONS

Digital versions of *Be Inspired Awards* publications are available online at www.bentley.com/yearininfrastructure. Choose to view a specific issue or search within each issue using terms, titles, or keywords.

Also browse Bentley's *Be Inspired Project Portfolios* at www.bentley.com/projects, which feature the winners and finalists in Bentley's annual *Be Inspired Awards* competition. Through these multimedia portfolios of exemplary project achievements, Bentley shares innovative best practices with the architects, engineers, constructors, geospatial professionals, and owner-operators who sustain the world's infrastructure.



Published by Bentley Systems, Incorporated
685 Stockton Drive
Exton, PA 19341
www.bentley.com

SAFE ENGINEERING DESIGN FOR INFRASTRUCTURE

The professionals who design, build, and operate infrastructure strive to combine advances in engineering knowledge with improvements to the quality of life for people around the world – and that goal is what drives the amazing projects presented in *The AutoPIPE Project Showcase*. Within these pages you will find works of infrastructure that are inspirational on many levels: for the distances they span, the people they connect, the water they clean, and the energy they produce.

Each of the projects presented here have been nominated for Bentley's *Be Inspired Awards*, our annual global competition recognizing outstanding achievements in design and delivery of infrastructure. They demonstrate our global society's resilience in the face of tremendous challenges, both economic and environmental, and serve as a testament to the ability of engineers and architects, contractors, and owner-operators around the globe to solve any problem, great or small.

These projects also represent tremendous innovation in the use of AutoPIPE advanced software for pipe stress design and analysis to enable companies to deploy proven, scalable and integrated projects. The projects you will read about here are state of the art, employ AutoPIPE for pipes stress analysis and design, together with other Bentley Plant modeling and design tools such as OpenPlant, AutoPLANT, STAAD.Pro and ProStructures to create new and sustainable value in every stage of the infrastructure lifecycle.

The breadth of infrastructure supported and the global reach of solutions indicate why AutoPIPE is a leader in piping analysis and design software used around the world in industries including offshore, oil and gas, power generation, process manufacturing, and wastewater, and for nuclear power plants where it is use for the highest levels of safety design.

Leading EPCs worldwide have the utmost confidence in AutoPIPE with its highly intuitive and productive modeling interface, and full integration with Bentley software, including ProjectWise, as well as other CAD tools. AutoPIPE enables overall faster engineered piping systems, and has been backed by nuclear quality assurance to ASME NQA-1 and ISO 9001 for over two decades. Each project has its own story and unique way in which AutoPIPE and other Bentley products have been used to gain benefits for both owner-operators and EPCs.

TABLE OF CONTENTS

OFFSHORE ENGINEERING	3 – 5
OIL AND GAS	7 – 9
POWER GENERATION	11 – 17
PROCESS MANUFACTURING	19 – 23
STRUCTURAL ENGINEERING	25 – 26
WATER OR WASTEWATER TREATMENT PLANTS	27 – 30
INDEX	31

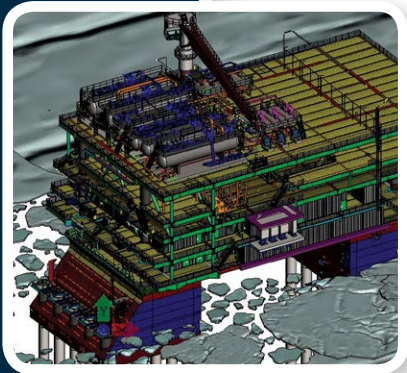

Offshore Engineering

The projects in this category represent tremendous innovation in the use of Bentley software to produce intelligent infrastructure that is measured in terms of operational efficiency, constructability, safety, and the use of energy and non-renewable resources in marine environments.

OFFSHORE ENGINEERING

CNGS Engineering

Central Process Platform – V. Filanovsky Oil Field

Caspian Sea, Russia

FINALIST

This RUB 16 billion ice-resistant offshore platform is one of the largest and, due to extreme conditions, most complex projects in the Caspian Sea. In the coldest months, the peak temperature averages -20°C (-4°F) and can drop as low as -36°C (-32.8°F). The support units were designed using 3D modeling to sustain the platform's massive weight as well as prevent ice-load damage.

CNGS Engineering is leading a group of eight subcontractor team members who are using ProjectWise to eliminate file-transfer difficulties. Other software being used on the project includes SACS, AutoPIPE, AutoPLANT Piping, Bentley Piping, Bentley OpenPlant PowerPID, Bentley PlantSpace Equipment, Bentley PlantSpace Piping, Bentley Building Mechanical Systems, MicroStation, Bentley Navigator, and promis•e.

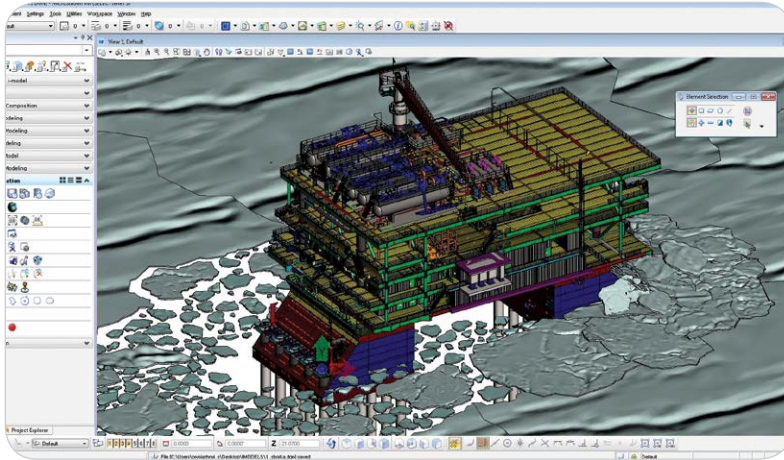

2013 FINALIST

Knowsley SK

Offshore Production Platform Deluge Skid

Manchester, United Kingdom

A USD 2.5 million fire-fighting foam deluge skid for use on an oil-and-gas floating production, storage, and offloading unit was designed to be compact and lightweight yet able to withstand extreme weather of the North Sea and Gulf of Mexico. The challenge was to design the skid to withstand more than 30 load conditions including transportation, rough seas, and high winds.

With a design-build schedule of 26 weeks, Knowsley saved time by exporting piping and structural models from current CAD applications to AutoPIPE and STAAD.Pro. Integrating the piping and structural models allowed engineers to analyze pipe work and steel work interaction under stress. This workflow saved an estimated 220 man-hours and reduced material costs by 10 percent.

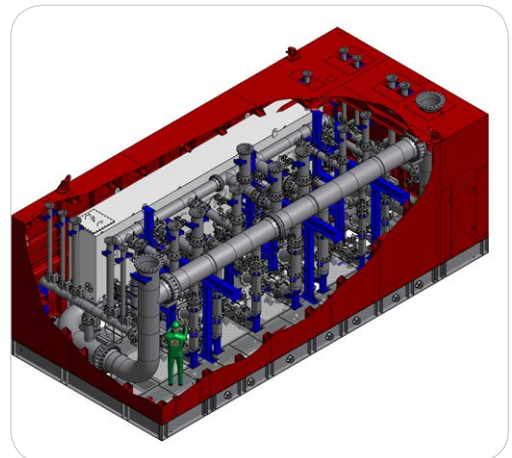

RNZ Pegasus Asia Pacific Sdn. Bhd.

Pipeline and Riser Detailed Design Engineering

West Belulut, Terengganu, Malaysia

Newfield Peninsula Malaysia is the operator of Malaysia Block PM323, located in the Malay Basin in the South China Sea. Two additional offshore platforms are planned as part of the oil field expansion. One, the West Belulut Wellhead Platform, is unique because it consists of a four-inch pipeline piggy-backed onto the 10-inch pipeline. The challenge was to simulate the support conditions at the piggy-back blocks along the pipeline.

Using AutoPIPE, RNZ Pegasus Asia Pacific designed the riser and evaluated the static stress level within the riser and pipeline system. In addition, the team simulated the effects of pressure at pipe bends and closed ends, thermal expansion, applied loads, support movements, pipe/soil interaction, pipe/support friction, support restraints, and environmental loads. AutoPIPE analyzed the two pipelines in one 3D model.

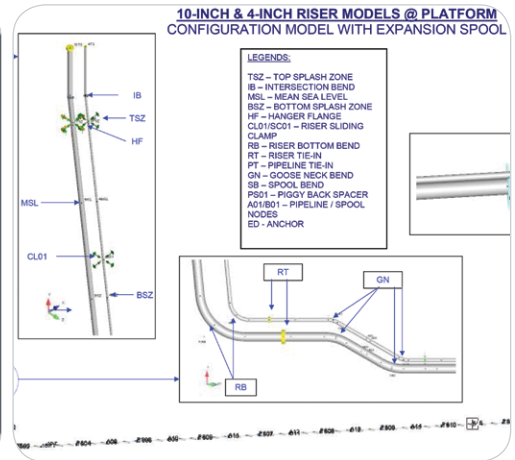
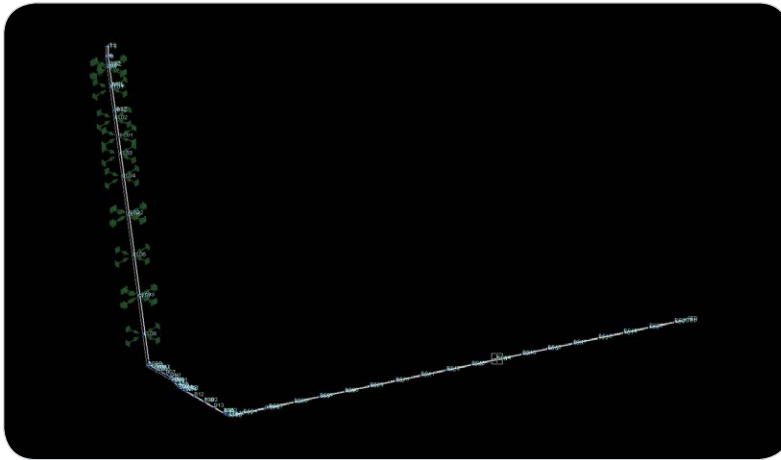

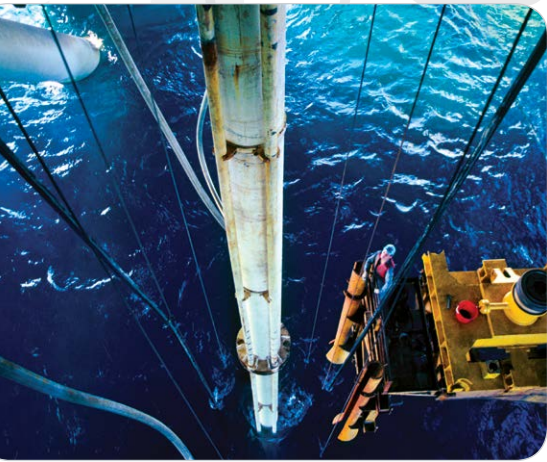

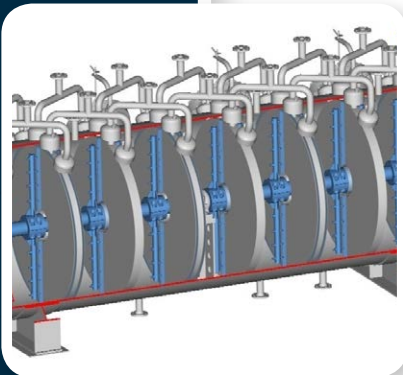
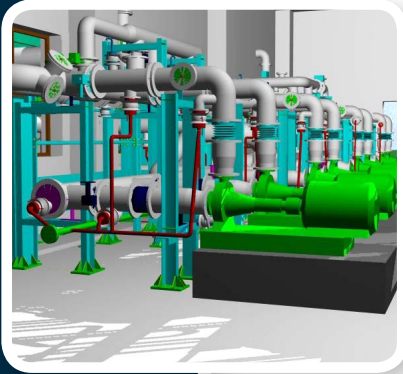

Oil and Gas

The projects in this category cover a wide range of upstream and downstream oil and gas production facilities.

OIL AND GAS

Kokoprojekt S. z o.o.

Plant for Deacidification and Ammonia Desorption

Krakow, Poland

The primary goal of the project was to design a modern plant in Krakow, Poland, for deacidification and ammonia desorption from process water. Kokoprojekt saved significant time by implementing 3D modeling. The relatively small size of data files and drawings provided the capability to efficiently analyze the model and avoid possible clashes, improving the quality of work and reducing the cost of erection.

Enabled by AutoPLANT, AutoPIPE, ProSteel, and ProjectWise, the firm avoided costly mistakes, better synchronized the multistage project preparation process, and gained a higher overall quality at a lower cost. The total project was completed in four months, as compared to the typical time frame for this kind of project of about 12 months.

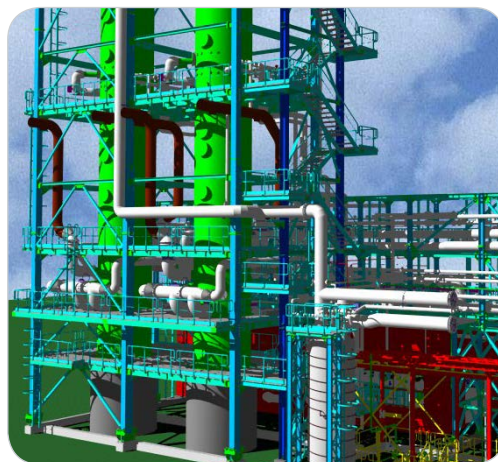
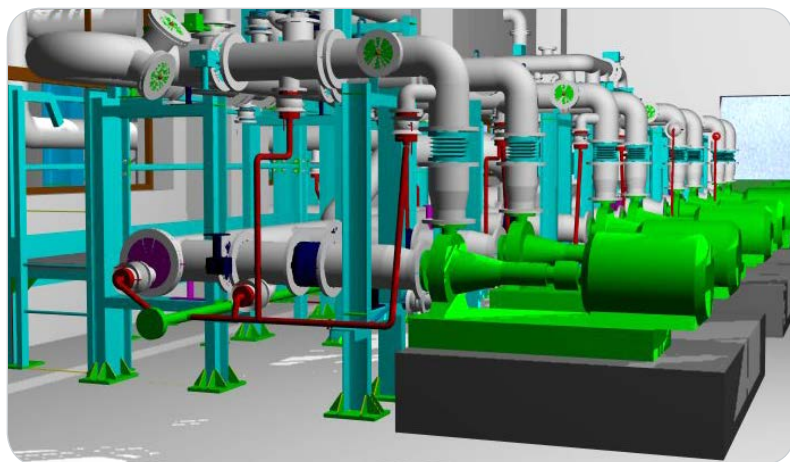

NK Rosneft–NTC

VNK1

Krasnoyarsk, Russia

As part of a major Siberian oil field development project, this project encompassed the development of an oil processing facility in the Krasnoyarsk Territory. The facility will be one of the largest crude extraction and processing plants in Siberia, Russia.

To optimize team performance, engineers and subcontractors from various disciplines were trained to use Bentley products. AutoPIPE and AutoPLANT allowed simultaneous model development among disciplines and enabled fast design reviews. Bentley products minimized project development time and improved overall project quality.

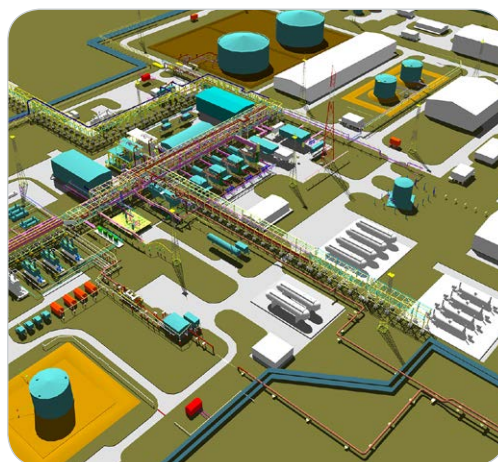
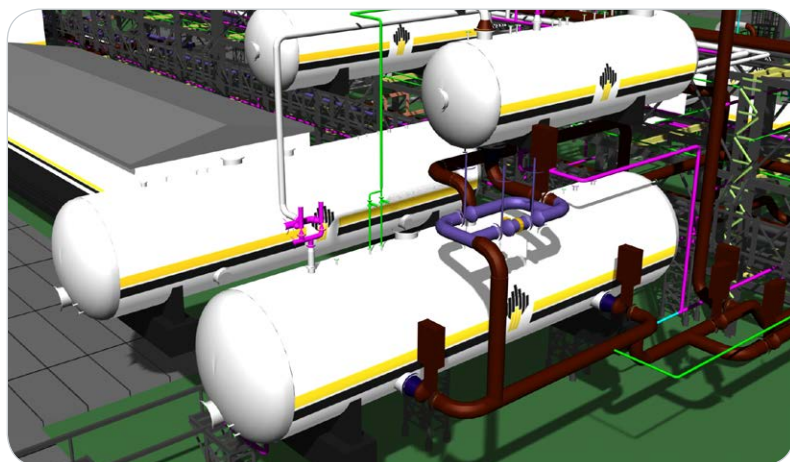

Petrochim Engineering Crystalliser Disk Regenerativ Orsk and Kstovo, Russia

Russian firm Petrochim Engineering, in cooperation with Israel-based Yutec Technologies, designed a disk-type crystallizer for a dewaxing unit to obtain higher quality oils to meet strict emission regulations. The goals were to reduce overall dimensions, ensure soundless unit operation, and define loads on vessel body and internals with maximum accuracy.

AutoPIPE designed the crystallizer components, reduced vessel dimensions, and defined optimum locations for disks and supports on the 8-meter bearing hollow shaft. Using this software for calculation of forces due to external loads also accelerated design. The new unit increased dewaxed oil yield by 3 to 4 percent and decreased oil content in slack wax by 30 percent. Harmful solvent leaks were completely eliminated, and noise was considerably reduced.

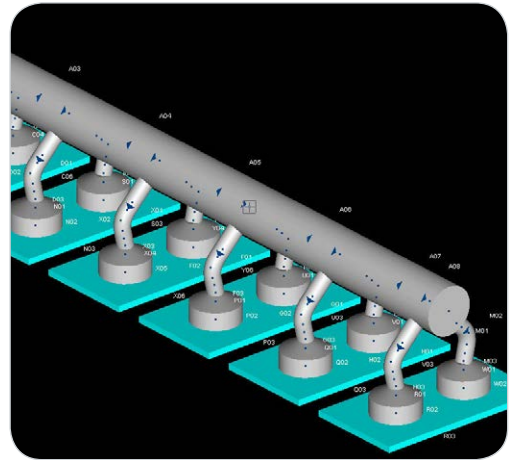
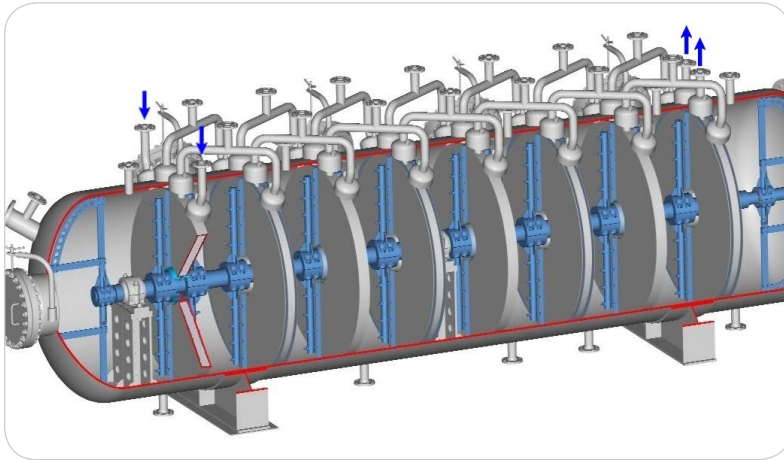

Ukratnafta Unit of Additional Reactor Kremenchug, Ukraine

Ukratnafta, a Ukrainian oil refining company, installed an additional reactor to improve quality and expand production at the Kremenchug refinery. The project was undertaken at an operating installation in constrained conditions. Design works were conducted in parallel by several departments. To find the most durable design solution for piping, the project team imported the piping model into AutoPIPE to test for resistance under high temperature and pressure.

More than 10 variations of the pipeline configuration were tested, including different configurations of suspension brackets and thicknesses of pipeline walls, and the variant corresponding to the requisite durability conditions was selected. Using AutoPLANT and AutoPIPE enabled Ukratnafta to work simultaneously with several working models and, as a result, choose the best design.

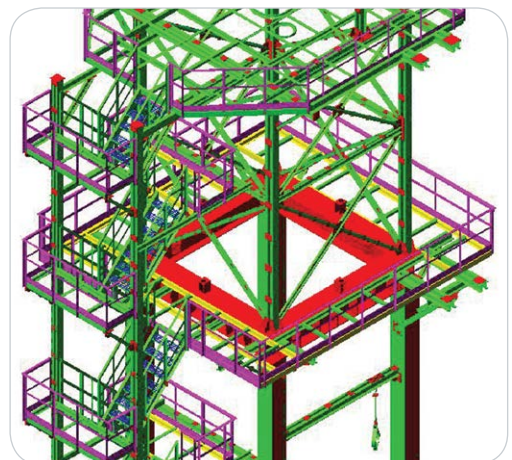
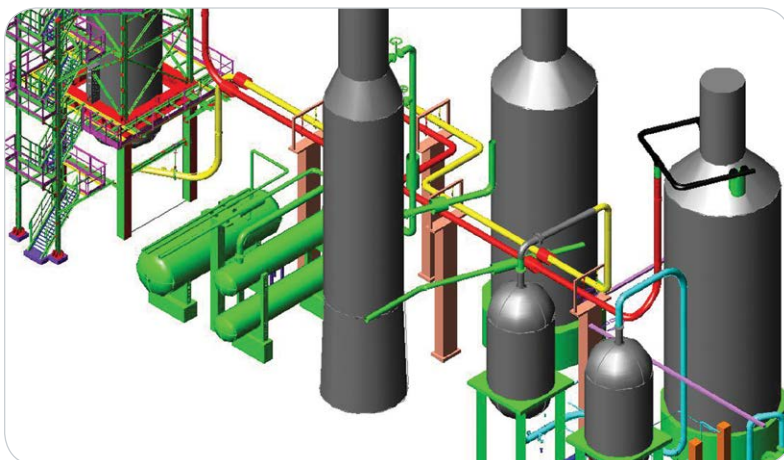



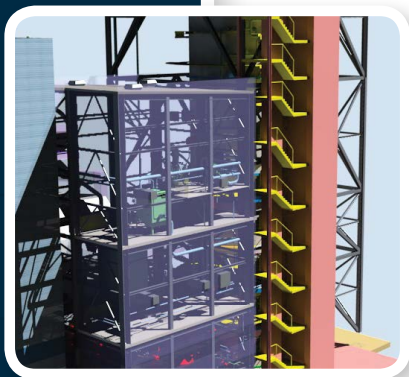
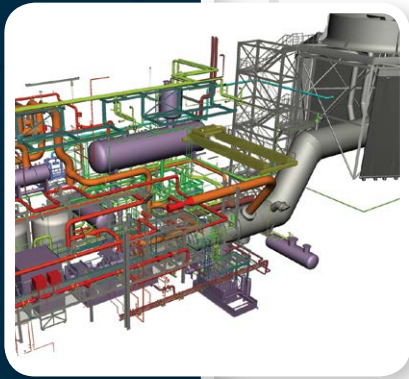

Power Generation

Projects in this category demonstrate excellence in planning, designing, building, operating, modeling, and analyzing power generation plants including traditional fossil fuel plants, combined cycle plants, and nuclear power facilities.

POWER GENERATION

Control Process S.A.

LMG CHP Plant (Part of Gas and Oil Mine)

Miedzzychod, Poland

The Lubiatow-Mi dzychód-Grotow (LMG) oil field is located in western Poland. A USD 35 million combined heat and power plant is under construction to supply power to the LMG oil and gas production and processing facilities by tapping gas from the well sites. PBG is the general contractor for the installation. Control Process was contracted to design, build, start up, and commission the 10-megawatt CHP plant.

Using PlantSpace to create 3D models helped to avoid collisions within the installation. AutoPIPE and Bentley View allowed the project team to verify and modify piping routes, and rapid generation of ISO drawings simplified the preparation of pipelines for manufacturing. The 3D model was also an effective tool for communicating design progress to the client.



Doosan Heavy Industries & Construction Co., Ltd.

Cebu Coal-Fired Power Plant (100MWx2)

Naga, Philippines

Doosan Power Systems India designed and engineered a USD 120 million power plant with a circulating fluidized bed combustion boiler. Located in the Cebu province of the Philippines, the 2x100 megawatt plant required a high degree of collaboration among an interdisciplinary team of engineers. The concept of concurrent design was applied across all disciplines to achieve the required quality, reduce non-conformances on site, and deliver the project on time.

MicroStation, Bentley speedikon Architectural, STAAD.Pro, STAAD.foundation, and AutoPIPE contributed to a 50 percent reduction in interference check time, 80 percent reduction in site non-conformances, and 95 percent on-time delivery. The use of this advanced technology helped the project team to incorporate existing facilities in the design and minimize the impact on the environment.

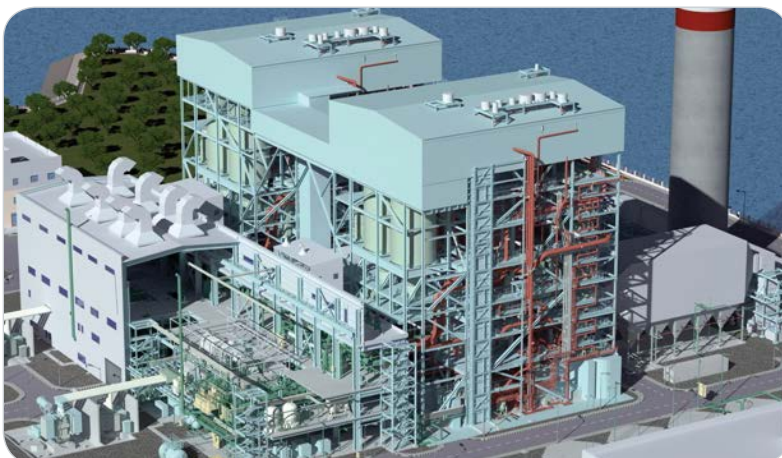

Energotechnika Projekt Sp. z o.o.

EC Zeran Modernization

Warszawa, Poland

Energotechnika Projekt's primary objective is to develop and execute capital projects on schedule, within budget, and with operational excellence. For the \$55 million EC Zeran Modernization project in Warszawa, Poland, the firm replaced an aging turbine with modern equipment that optimized the fluidized boiler, enabling greater efficiency in thermal-to-electric energy conversion.

The challenge was to install the modern turbine in the existing facilities and coordinate installation between branches within a short time. The design team used Bentley Structural, AutoPIPE, and AutoPLANT to shorten design time and reduce the number of people involved in the project.

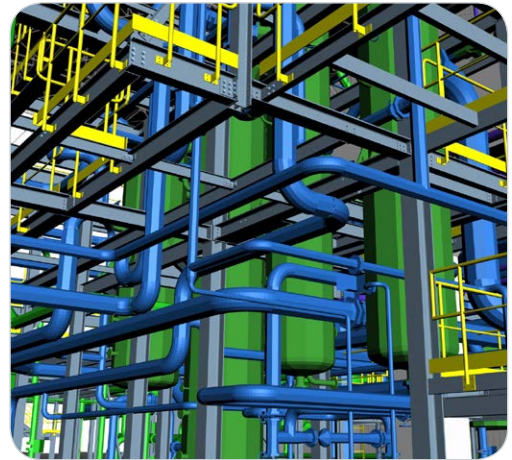
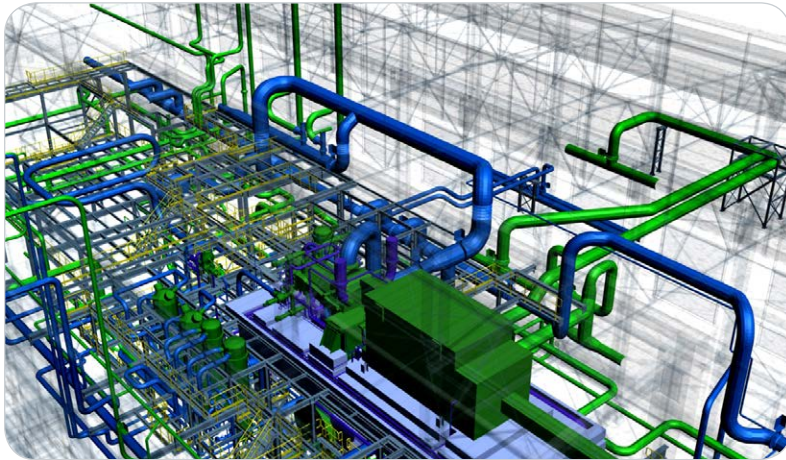

Energotechnika Engineering Sp. z o.o.

Imos Gdynia

Gdynia, Poland

As the largest energy company in Northern Poland, EDF Wyrzeze S.A. owns and operates the Gdansk and Gdynia power plants, with total heat capacity of 1,206.5 megawatts and total power generation capacity of 322.5 megawatts. Installation of wet flue gas desulfurization was required to bring the Gdynia plant into compliance with European Union legislation for emissions control. The PLN 4 million project will reduce sulfur dioxide emissions by about 70 percent and ash by about 55 percent.

New cross-industry standards and design coordination were the main challenges for Energotechnika Engineering. The use of Bentley products, including MicroStation PowerDraft, Bentley AutoPIPE, ProjectWise, Bentley Navigator, and Bentley PlantSpace products, allowed the team to create a spatial model for visualization and coordination of the technical solutions, thereby avoiding collisions between contractors.

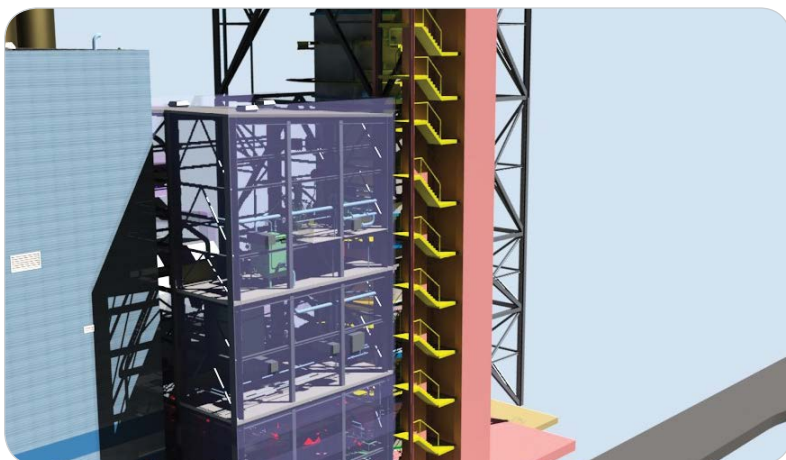

POWER GENERATION

Energotechnika Projekt Sp. z o.o.

IP Kwidzyn Power Plant Expansion

Kwidzyn, Poland

Energotechnika Projekt is one of the largest engineering, procurement, construction, and project management companies in Poland. The goal of the IP Kwidzyn Power Plant Expansion project was to improve plant efficiency and production capacity while decreasing environmental emissions.

The primary goal was to quickly connect the expansion to existing facilities and coordinate installation between branches. The design team used Bentley Structural, AutoPIPE, and AutoPLANT to overcome challenges involved in this USD 26 million project to achieve cost savings.

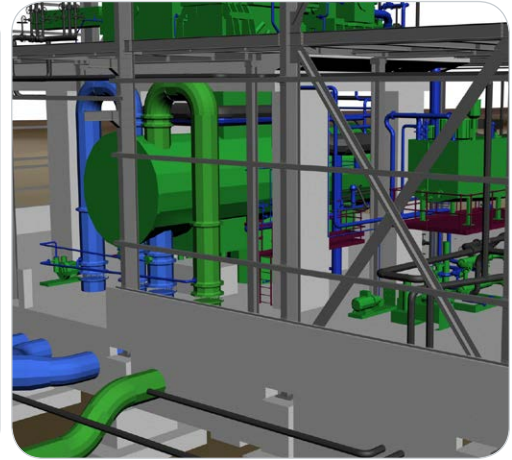
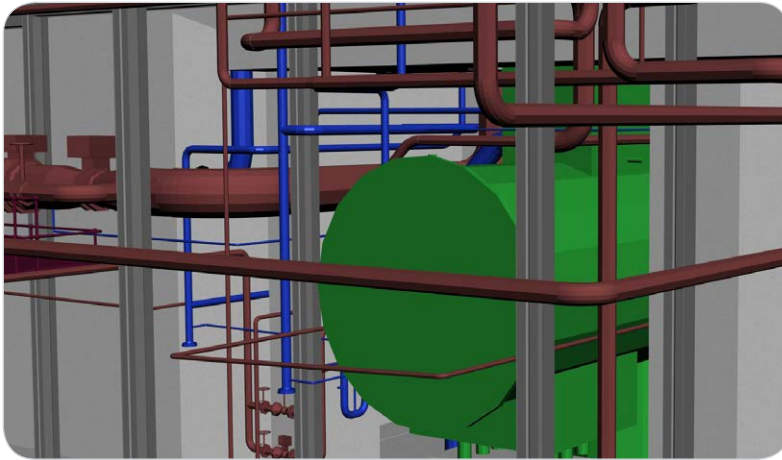

Fabricom GDF SUEZ

SITA Re-Energy Bavro Project

Roosendaal, Netherlands

Bavro is a USD 31.8 million SITA Re-Energy project in Roosendaal, Netherlands. It is a high-efficiency incineration installation for industrial and domestic waste with a capacity of 291,000 tons a year. Fabricom's project goals for this waste-to-energy installation were to increase capacity to meet the growing demand for waste disposal and to recover more sustainable energy from waste.

Fabricom relied on AutoPLANT, AutoPIPE, and ProSteel for delivery of 2D and 3D information, leading to faster communication among all of the parties involved. The project was based on interoperability between services. By reusing the data for all civil, building, plant, and structural project teams, the company saved time and improved data reliability.

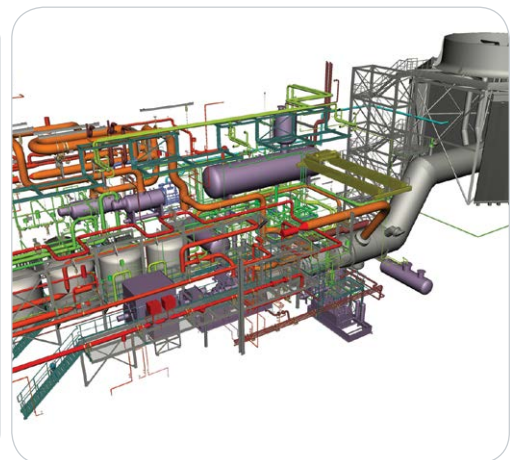

KEPCO Engineering & Construction Company, Inc.

Yonghung Thermal Power Plant Units 3 & 4

Yonghung, South Korea

KEPCO Engineering & Construction provided comprehensive design services for Yonghung Thermal Power Plant, Units 3 and 4, which added two 800-megawatt units to the coal-fired power plant located on Incheon's Yonghung Island southwest of Seoul, South Korea. KEPCO achieved time-saving efficiencies in all aspects of design, engineering, and construction support for the USD 4 billion plant.

Using MicroStation and Bentley PlantSpace established an intelligent design environment, enabling designers to become 20 percent more productive. Other Bentley products that improved communication among the contractors, vendors, engineers, and the client included AutoPIPE and STAAD.Pro. Snapshot views of the 3D model were used instead of traditional 2D drawings at the construction site.

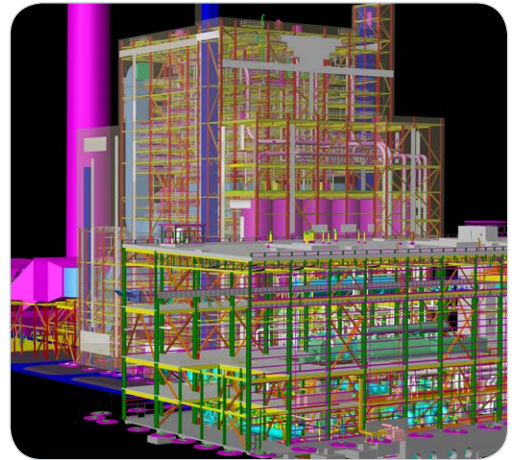
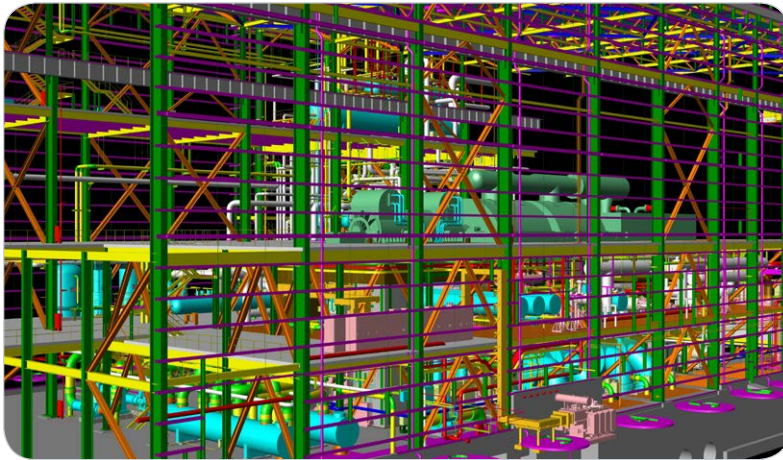

Projenia S.r.l.

6th of October Power Plant

6th of October City, Cairo, Egypt

Cairo Electricity Production Company awarded a EUR 245 million engineering, procurement, and construction contract to Ansaldo Energia to build the 6th of October Power Plant on the outskirts of Cairo, Egypt. The 600-megawatt open-cycle power generation plant consists of four 150-megawatt gas turbines. Projenia was retained to perform detail design of the plant, including civil and architectural works, piping and mechanical design, and electrical and instrumentation design.

The short nine-month schedule was achieved by using the AutoPLANT integrated 3D environment and Bentley AutoPIPE and STAAD.Pro calculation tools to exchange information among engineering disciplines. Bentley solutions produced an optimal design in 15 percent less time and enabled a faster erection schedule – just 14.5 months – by producing a clash-free, erection-oriented arrangement that required minimal on-site queries or claims.

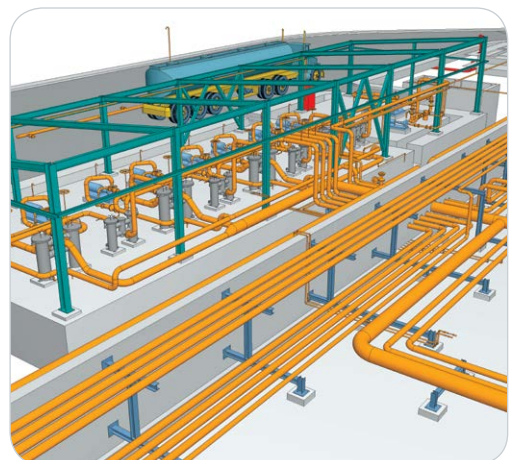

POWER GENERATION

Projenia S.r.l.

Marcinelle CCGT Power Plant

Charleroi, Belgium

Located at the Carsid Complex in Charleroi, Belgium, the Marcinelle Energie combined-cycle gas turbine power plant has a design capacity of 410 megawatts. Enel Ingegneria e Innovazione acted as the engineering, procurement, and construction contractor, while Projenia provided engineering design services including preliminary plant layout, mechanical plant and piping detail design, and balance-of-plant instrument positioning.

Projenia created a 3D model of the overall power plant. AutoPLANT and Bentley AutoPIPE were used to achieve a clash-free design and erection-optimized layout. The 3D integrated environment based on Bentley products ensured multi-discipline coordination among engineering teams working from various locations. The 3D integrated design process reduced design time by 10 percent, significantly reduced the erection cost, and improved plant operability by optimizing space for maintenance and safety.

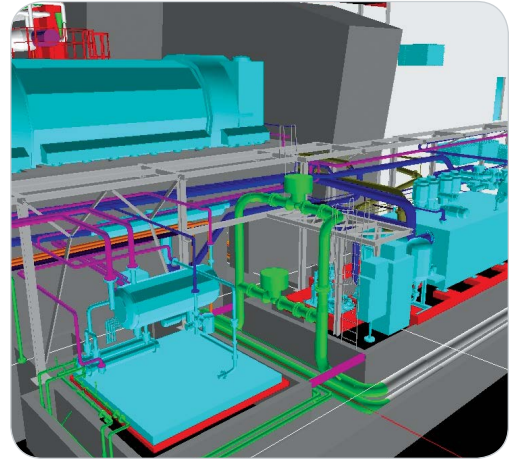
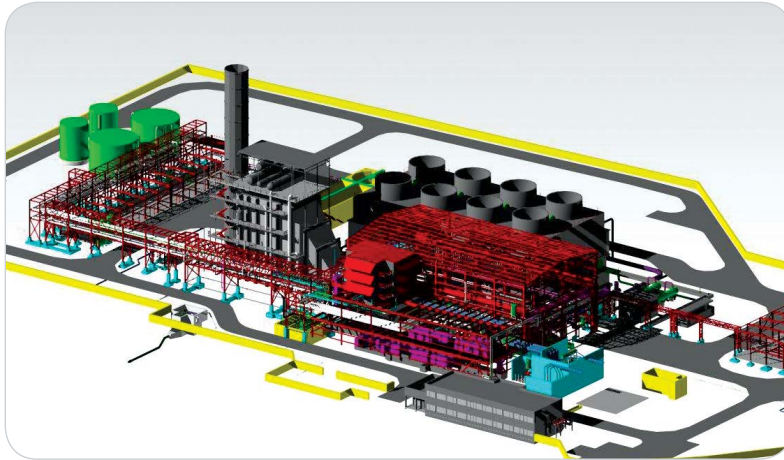

Shaw Power Group

Virginia City Hybrid Energy Center

Virginia City, Virginia, United States

FINALIST

Shaw Power Group was awarded a USD 1.5 billion engineering, procurement, and construction contract for execution of the 585-megawatt circulating fluidized bed (CFB) electric power generation station near St. Paul, Virginia. Known as the Virginia City Hybrid Energy Center, the project included a 650-megawatt steam turbine generator, two CFB boilers, associated infrastructure, equipment, and vendor-supplied systems.

After initiating the project on MicroStation and Intergraph PDS, Shaw transitioned to Bentley PlantSpace to improve engineering and construction performance. The integrated application suite was implemented while the project was in full swing with no impact on budget or the 58-month schedule. Interferences were resolved during 3D design, and construction was completed with no on-site rework.

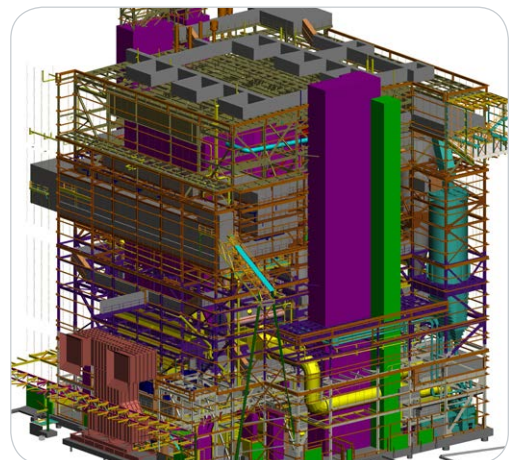

SPECIAL RECOGNITION AWARD WINNER – ADVANCING INFORMATION MOBILITY

2012 FINALIST

United Conveyor Corporation (India) Pvt. Ltd.

Fly Ash Handling Project

Moundsville, West Virginia, United States

At American Electric Power's Mitchell Plant near Moundsville, West Virginia, United Conveyor Corporation (India) completed an ash handling project using AutoPLANT and Bentley AutoPIPE. The 3D models saved time on this USD 150 million project by visualizing the components used to convey fly ash from its source in the coal-fired power plant to its destination, where it can be recovered for reuse in building and other materials.

UCC India offers state-of-the-art ash handling and pneumatic conveying technology from its parent company, United Conveyor Corporation, USA. The system for this project combined vacuum and pressure conveyance to collect fly ash from hoppers in the electrostatic precipitator area and convey it to a storage silo. Valves in the pipe controlled the flow and distribution of ash and air.

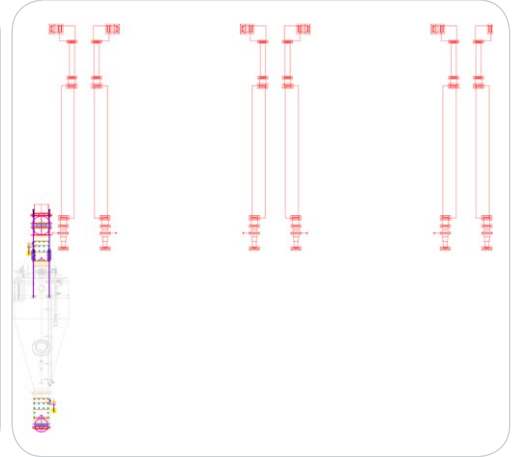
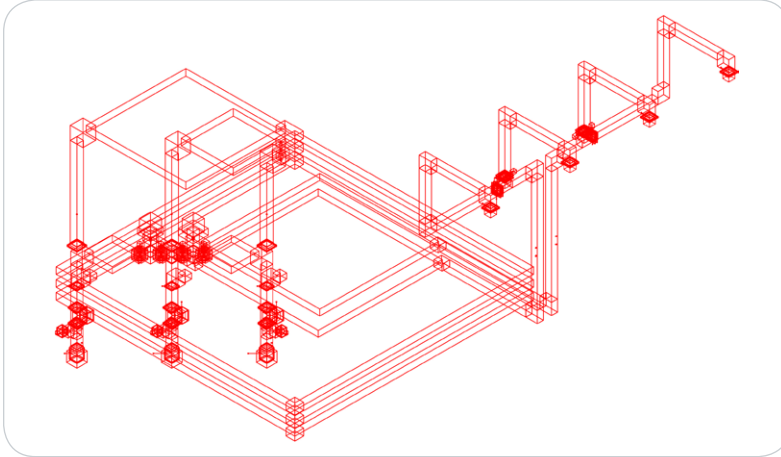

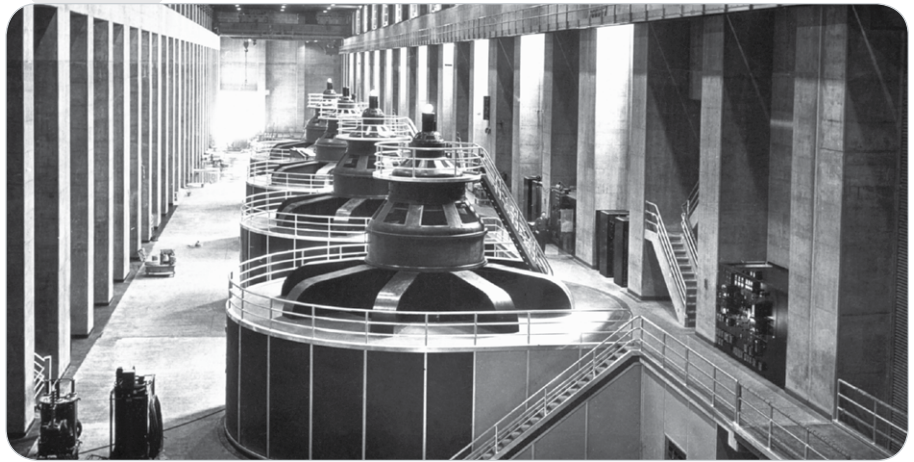

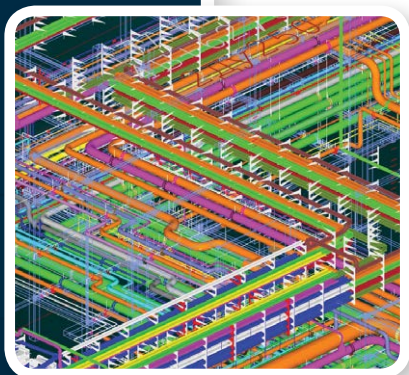
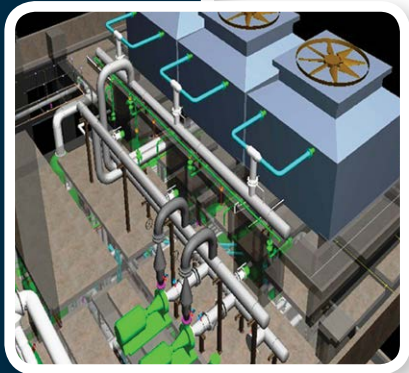
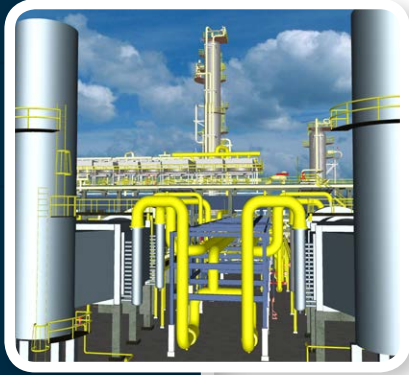

Process Manufacturing

This category covers a wide range of industries including petrochemical and chemical complexes, pharmaceutical and manufacturing plants, and more.

PROCESS MANUFACTURING

Ausenco Engineers Pvt. Limited (Ausenco Sandwell)

Continuous Polymerization Plant

Bajpur, India

Polyplex India set up an 8.7-meter-wide polyester (PET) film line with a continuous process chips plant and metalizer at a new location in Bajpur, India. Ausenco Sandwell developed the 3D model to generate a clash-free piping and equipment layout for the chips plant comprised of 180 to 200 pieces of equipment and 650 lines. The project also called for high-end process conceptualization, piping material specification, and modeling of specialized equipment.

AutoPLANT was used to develop a model meeting all process requirements and extract drawings, isometrics, and bills of quantity. The stress model for critical pipelines analysis was created in AutoPIPE and structural design and detailing was completed using STAAD.Pro and ProSteel. The modeling seamlessly integrated all design groups and contributed to achieving a tight execution schedule with minimum rework.

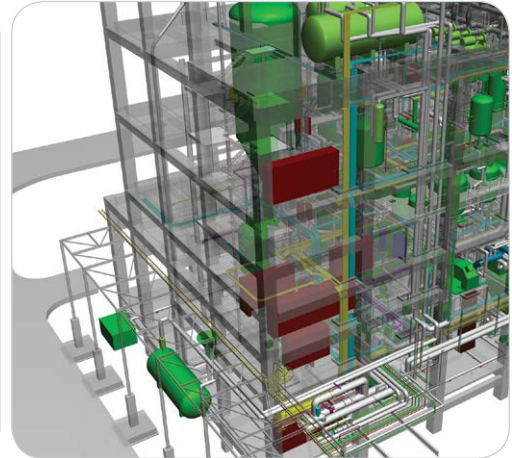
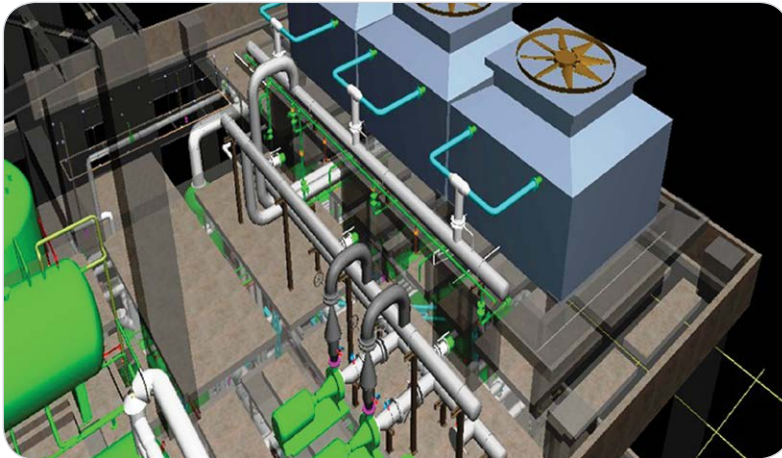

BashNIPneft

Trebs Oil Field: Central Collection Point

Naryan-Mar, Russia

Bashneft, one of the largest oil producers in Russia, holds the license for development of the Trebs oil field located in the Arctic region of Nenets Autonomous Okrug. Bashneft's research and development institute, BashNIPneft, a leading research institute in the field of oil and gas exploration, was contracted to execute the Central Collection Point project.

With training and technical support from Bentley's partner in Russia, BashNIPneft implemented AutoPLANT for piping, equipment, and raceways in addition to AutoPIPE, ProStructures, STAAD.Pro, and Bentley Interference Manager. The 3D solutions reduced mistakes, exposed interferences, and expedited the project design and delivery.

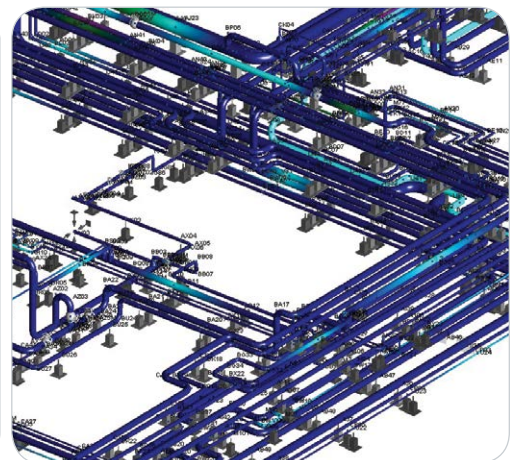
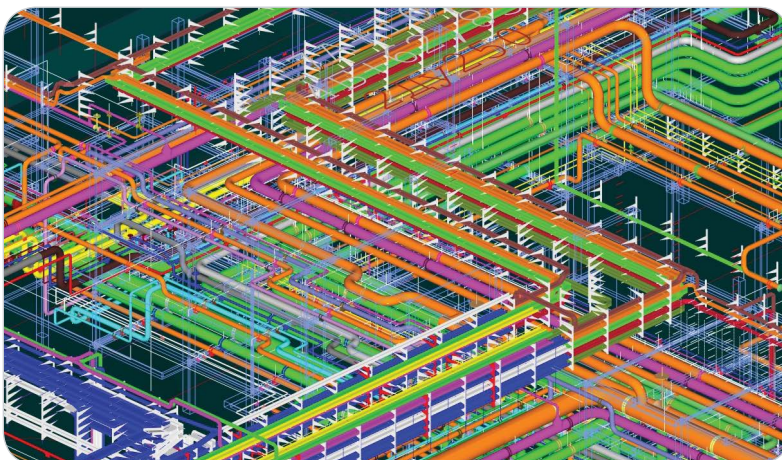

Giprovostokneft

Model for an Estimation of the Intense-deformed Condition of Piping Reservoir Park

Nenetskiy AO, Russia

Giprovostokneft developed a piping model to evaluate the stressed-deformed state of pipelines at a central production facility in Nenetskiy AO, Russia. The calculations were complicated by connections with and proximity to branch pipes from tanks. The settlement model considered such elements as the pliability of tank walls, spring supports to compensate for tank movement, and motionless supports at points of connection between branch pipes and tanks.

Based on data obtained after a strength calculation, a plan was proposed for the location of pipelines in which the stress-strain state arising in the pipe and fittings operating at load would not exceed the allowable state. Sizing and placement of spring supports were also recommended. AutoPIPE was integral to this USD 600,000 project.

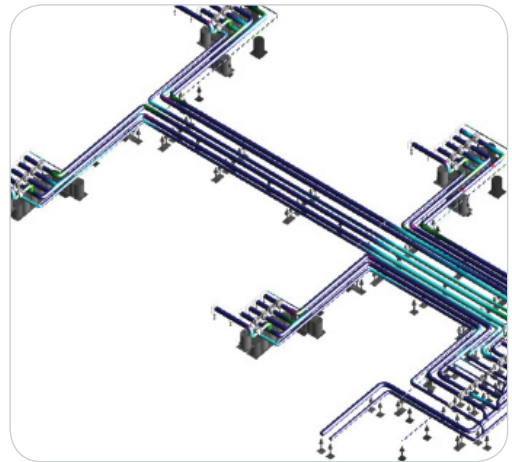
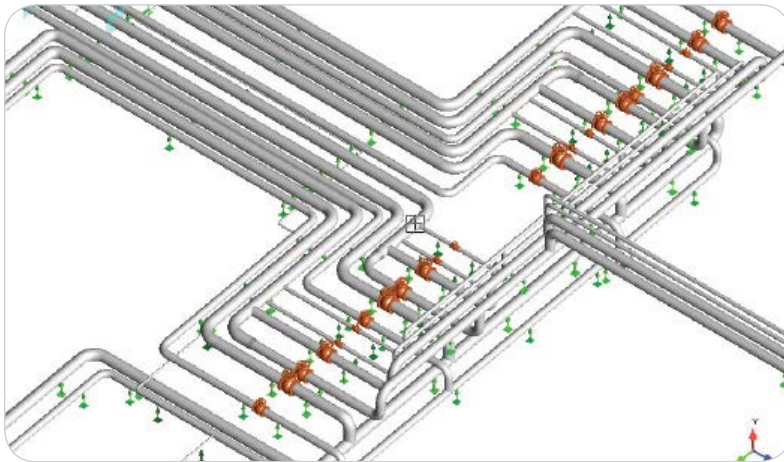

Kavin Engineering and Services Private Limited

FPU JOKOTOLE

Terang Sirasun Batur Field, Indonesia

Kavin Engineering and Services was retained to perform detailed engineering of the complete topside facility for a floating production unit to be stationed at the Terang Sirasun Batur Field in offshore Indonesia. The topside facility contains eight process modules requiring process, piping, mechanical, structural, electrical, and instrumentation. Collaboration among multiple disciplines was the key challenge on this USD 350 million project, along with conforming to client requirements and international standards.

Kavin took advantage of the data-centric approach inherent in AutoPLANT, ProSteel, STAAD.Pro, and Bentley Navigator. Piping, isometrics, and general arrangement drawings were done using AutoPIPE, and structural modeling and 2D drawings for pipe supports, handrails, ladders, and grating were performed using ProSteel. Raceways and instruments were modeled with AutoPLANT Raceways.

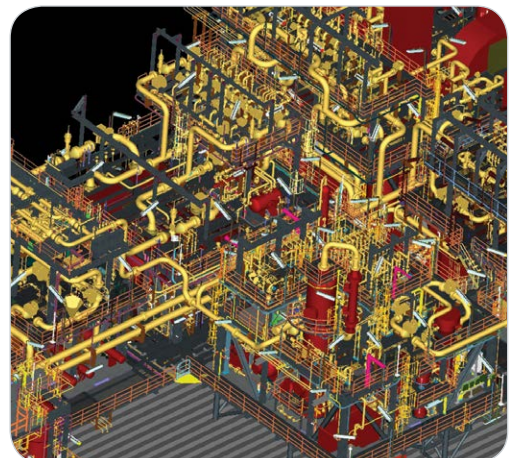
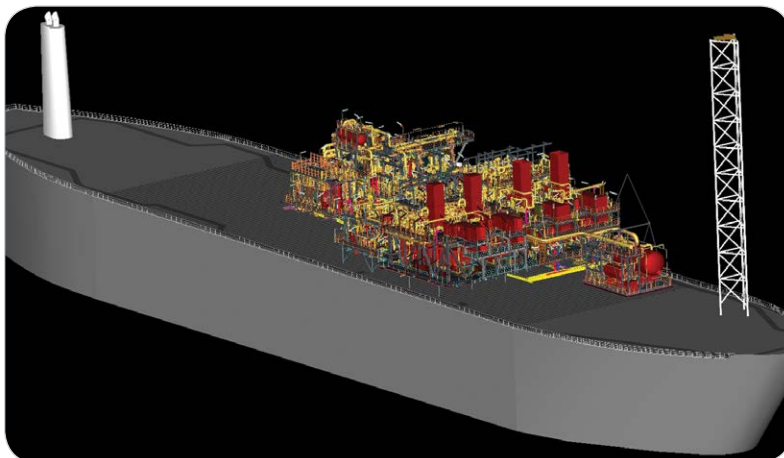

PROCESS MANUFACTURING

Larsen & Toubro Limited

Ammonia Plant Feedstock Changeover Project

Panipat, Haryana, and Bathinda, India

Under a government directive to bring down energy consumption per metric ton of ammonia, National Fertilizers Limited – a government of India undertaking – is converting ammonia plant feedstock from furnace oil/low sulfur heavy stock to natural gas/regasified liquefied natural gas. Larsen & Toubro was contracted to convert India plants in Panipat, Haryana, and Bathinda.

For this INR 23 billion project, Larsen & Toubro identified 60 critical systems with 300 critical lines of up to 40-inches and a maximum temperature of 546 degrees Celsius. MicroStation, Bentley Navigator, Bentley PlantWave, STAAD, and AutoPIPE saved time and effort in the design of the most complex piping systems. Easy extraction of load information, auto adjust for modifications, and easy modeling of piping cleat supports reduced overall design time.

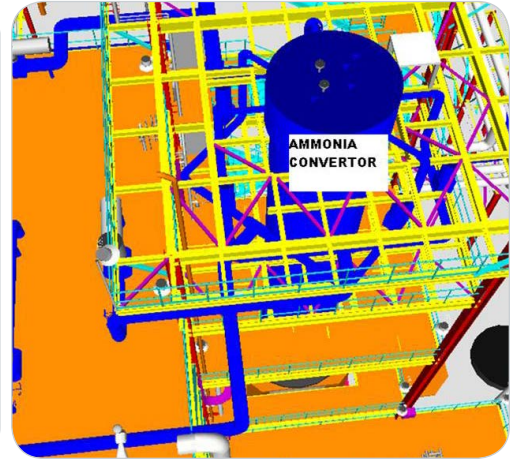
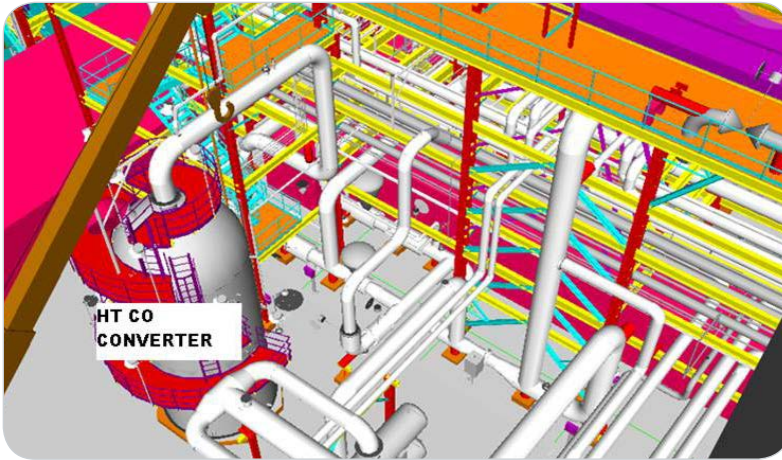

Larsen & Toubro Limited

Gas Recovery and Injection Project

Abu Dhabi, United Arab Emirates

FINALIST

Abu Dhabi Gas Industries is conducting a pilot test of gas recovery and injection at the Habshan Gas Processing Plant north of the United Arab Emirates' capital city. The USD 90.7 million project must be completed within 34 months. To bid on the lump sum turnkey project, Larsen & Toubro performed detailed engineering and construction modularization using Bentley solutions.

PlantWise expedited the pre-bid engineering package development, AutoPIPE calculated loads on critical lines, and STAAD.Pro checked the structural feasibility of piping runs. PlantWise generated annotated general arrangement drawings to ensure no clashes. Interoperability enabled fast and efficient 3D model generation, data sharing among disciplines, and shorter review times. Compared to other platforms, 3D modeling cost 2.25 times less using Bentley solutions.

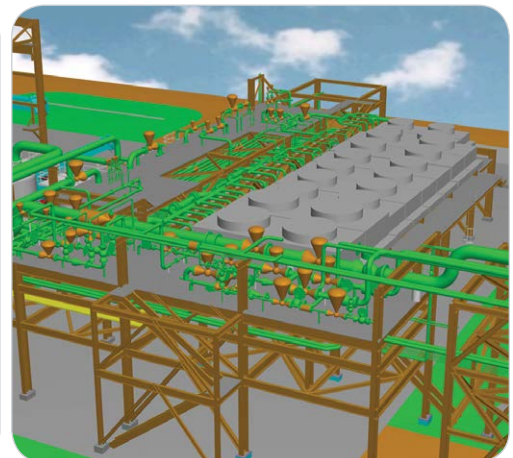
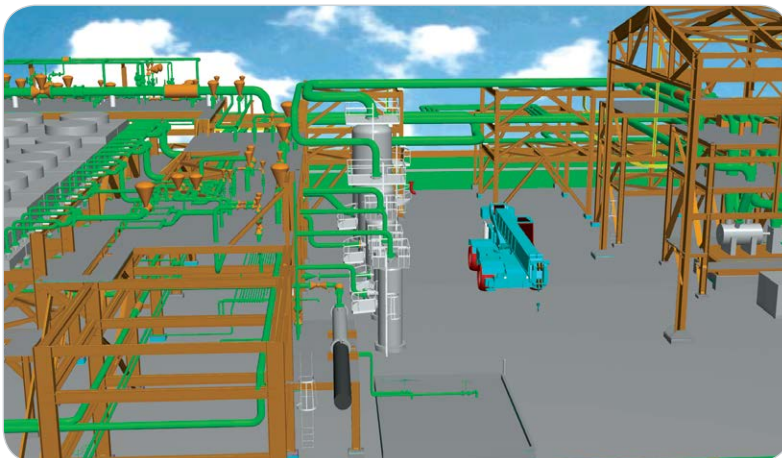

2011 FINALIST

FINALIST

**PT. Inti Karya Persada Teknik
Betara Complex Development Project
Jabung, Indonesia**

The USD 320 million Jambi Betara Complex Development Phase 3 & 4 Gas Plant in Jabung, Indonesia, is owned by PetroChina. As a subcontractor on the project, PT. Inti Karya Persada Teknik performed the detailed engineering of the Betara Gas Plant using Bentley tools to gain speed, accuracy, and reduce costs, and delivered PDS models as the owner mandated.

Intelligent 3D modeling was performed using MicroStation, GenerativeComponents, STAAD.Pro, ProSteel, AutoPLANT, AutoPIPE, and Bentley Navigator. The engineering team saved time by aggregating and assembling geometry from multiple software sources, and explored more design options in less time. The resulting design accuracy gave the construction team increased visibility and credibility.

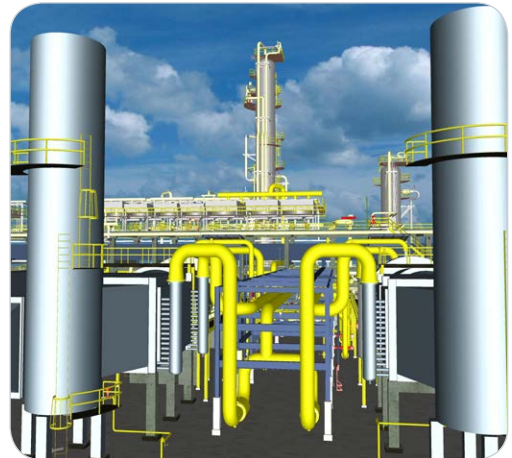

2012 FINALIST

WINNER

**Zeton Inc.
Modular GTL Commercial Demonstration Plant
Aracaju, Brazil**

Zeton designed and built the world's first modular gas-to-liquids (GTL) commercial demonstration plant using Compact GTL's mini-channel reactor technology. The USD 20 million plant incorporated all aspects required for commercial application in treating gas at remote and offshore oil fields. Access to a real-time 3D model during fabrication improved accuracy and reduced rework.

AutoPLANT provided the robust 3D plant modeling solution required to scale GTL technology from pilot to commercial and allowed team members on four continents to work together to resolve issues related to design of a compact, modular GTL plant. In addition to AutoPLANT, the 3D design was completed using ISOGEN for isometric piping drawings, AutoPIPE for pipe stress analysis, and ProStructures for structural steel design.



2012 WINNER



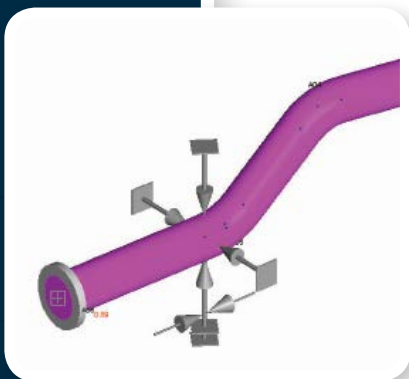
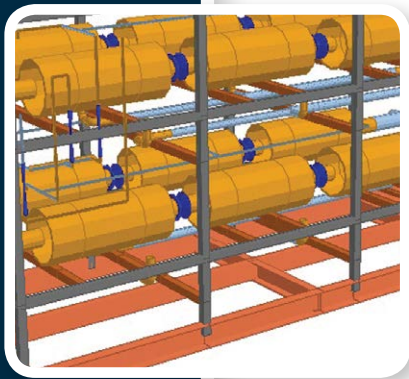
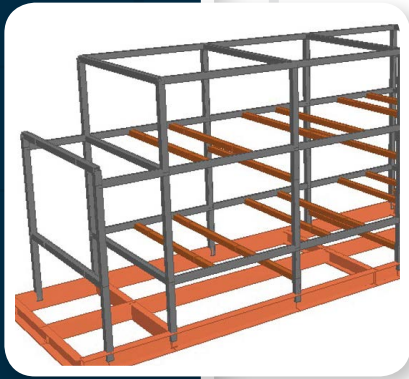

Structural Engineering

Projects in this category have demonstrated excellence in analyzing, designing, or delivering integrated piping and structures.

GE Water & Process Technologies

HERO Ultra Pure Water Systems

Bangalore, India

Ultra-pure water makeup systems using high-efficiency reverse osmosis (HERO) remove hardness, alkalinity, and/or dissolved gas from boiler feed-water makeup and cooling tower makeup water in the power industry. Ultra-pure water makeup systems also reclaim oily wastewater, organic waste, and cooling tower blow-down in the refinery sector. GE Water & Process Technologies designed a HERO ultra-pure water makeup system for a plant in Bangalore, India.

To design the supporting systems and interconnecting piping, GE Water used AutoPIPE and STAAD.Pro to verify code compliance for loading, lifting, shipping, operating, and severe seismic loading. The software integration, which helped in qualifying the product in the shortest amount of time and facilitated coordination with final assembly, fabrication, and production, saved 22 percent in material cost for 18 skids.

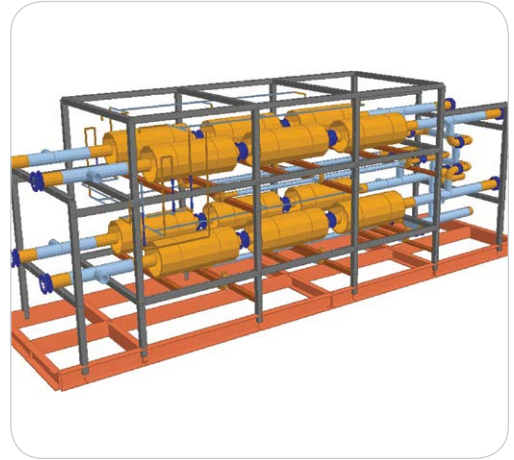
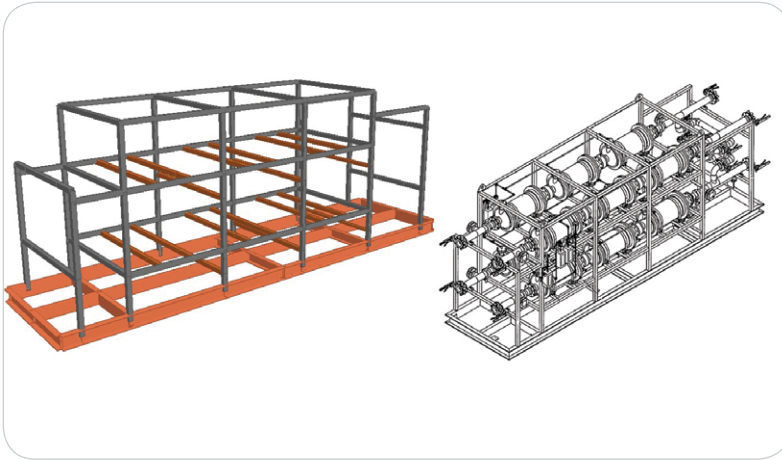

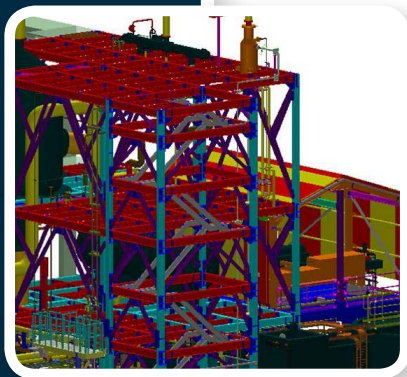
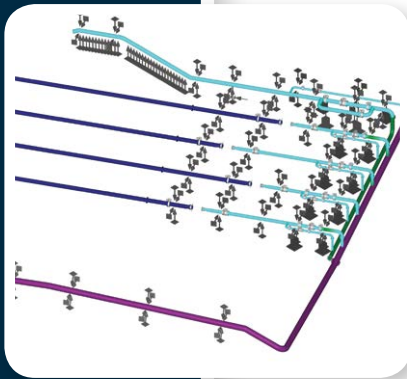

Water or Wastewater Treatment Plants

This category features projects that demonstrate the innovative use of technology to plan, design, manage, model, and construct water and wastewater treatment plants.

WATER OR WASTEWATER TREATMENT PLANTS

GE Water

Lanxess India – Thermal Zero Liquid Discharge Wastewater Treatment Plant

Nagda, India

FINALIST

GE Water is building a USD 4.6 million thermal zero liquid discharge plant to treat 260 cubic meters per day of wastewater generated by existing chemical plants at the Lanxess Complex in Nagda, India. The treated water will be reused for boiler feedwater make-up in power generation. GE Water reduced man-hours during design and modeling by about 42 percent, which saved approximately USD 16,800.

The entire plant was modeled using MicroStation and Bentley PlantSpace, which enabled the visualization, coordination, and optimization of equipment, piping, pipe supports, and cable tray layouts. Structural and piping analysis and design were performed using STAAD.Pro and AutoPIPE. The 3D model also enabled accurate bill of materials extraction.

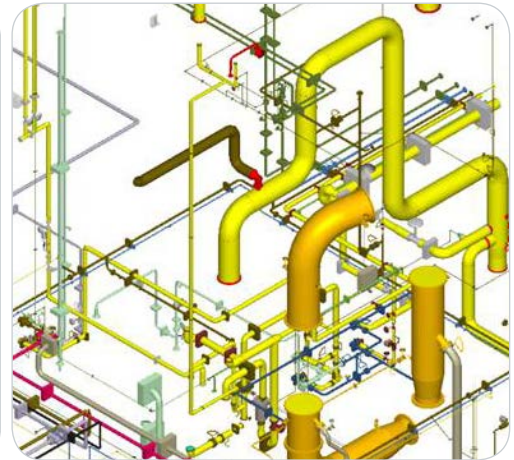
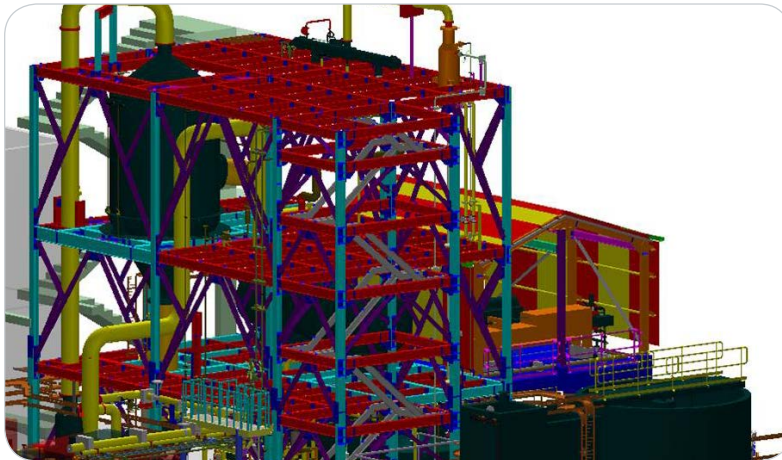

2012 FINALIST

GE Water & Process Technologies

Municipal Series – RO Systems

Bangalore, India

GE Water & Process Technologies developed a series of reverse-osmosis water purification systems to treat a wide variety of feed water for municipalities. To ensure code compliance, GE Water performed comprehensive analysis of various load conditions on the reverse-osmosis skid frame and high-pressure piping systems. As a result, the product achieved NSF Standard 61 certification and FDA compliance.

AutoPIPE and STAAD.Pro were used for analyses and design of the product, including checking interferences and finalizing pipe routing. Seamless software integration contributed to a shortened product qualification process, saving 60 percent of the analysis and design cycle time. The software also helped to coordinate with design teams on final assembly, fabrication, and production and so enabled the timely market launch of the product.

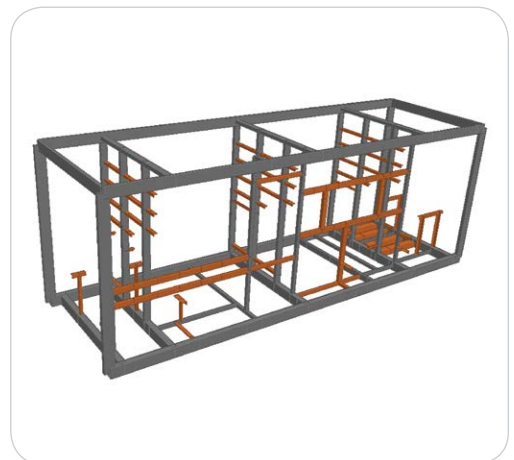

WATER OR WASTEWATER TREATMENT PLANTS

GMI S.A. Ingenieros Consultores

Fresh Water, Wastewater, Tailing, Reclaimed Water, and Seepage Systems Engineering

Arequipa, Peru

For this USD 350 million project in Arequipa, Peru, the objective was to use two pump stations to transport 6,480 cubic meters per hour of water through 15 kilometers of pipe from an equalization pond to a fresh water storage tank at the new 240,000 million-ton-per-day copper concentrator plant. Analysis of the pumping stations and pipelines considered sustained and occasional loads to ensure reliable, optimal water conveyance.

GMI used Bentley AutoPIPE for design and stress analysis of the piping system, supports, and anchor blocks. The software allowed analysis of critical points in the topography, as well as high operating and transient pressures. HAMMER was used to prevent water hammer in the pipelines and determine device protections. By minimizing potentially damaging forces against the system, GMI achieved an economical installation.

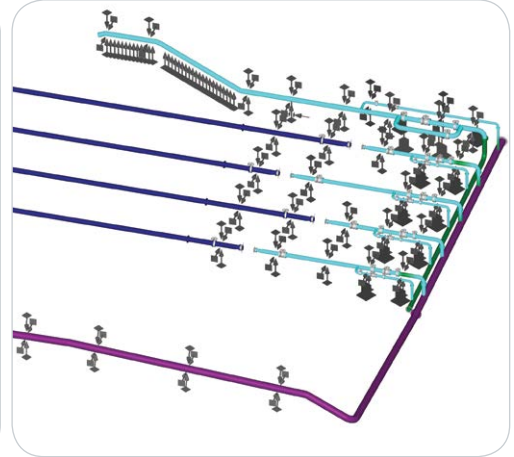
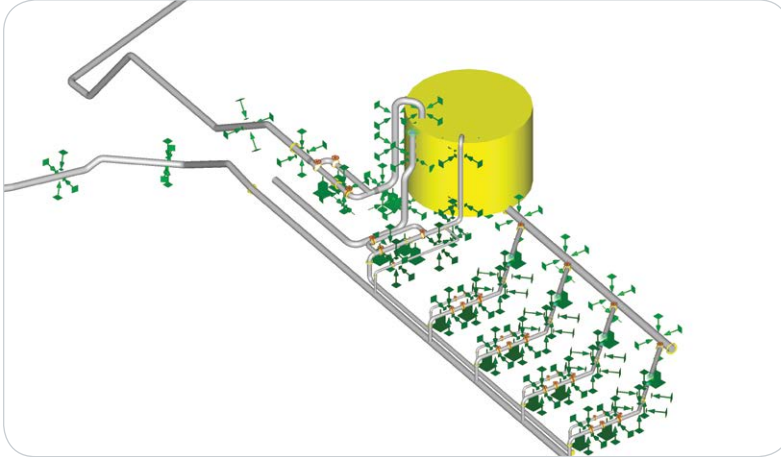

GMI S.A. Ingenieros Consultores

Potable Water Treatment Plant

Arequipa, Peru

The government of Peru awarded a project to extend the drinking water system in Arequipa, the second largest city in Peru. It involves extracting water from the River Chili and adding approximately 11 kilometers of pipeline to the drinking water treatment plant. GMI S.A. Ingenieros Consultores was retained to engineer the system for the USD 83 million project.

Obstacles included routing the pipeline through closing chambers, bridges, and tunnels. HAMMER performed calculations for superior designs that will prevent hydraulic shock in pipelines. AutoPIPE provided comprehensive pipe stress analyses and determined the necessary support and anchor arrangements, and minimized concrete and the number of supports. The products saved an estimated USD 500,000.

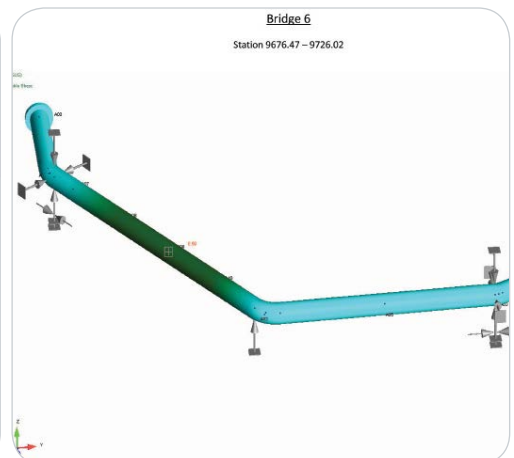
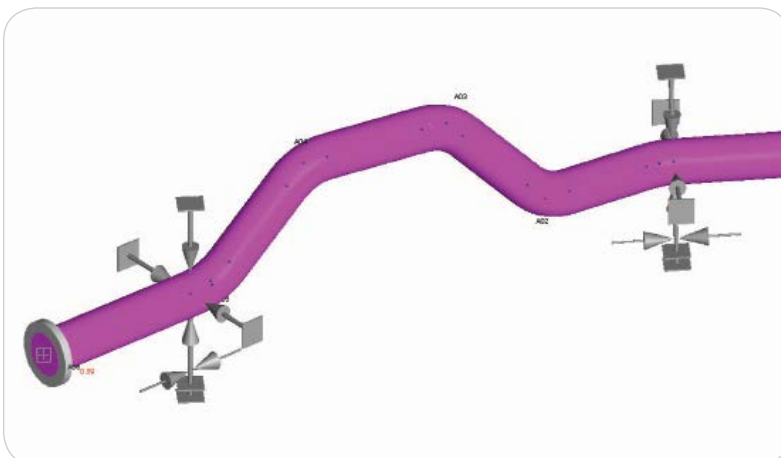

WATER OR WASTEWATER TREATMENT PLANTS

MECON Limited

100 MLD SWRO Desalination Plant

Chennai, India

This USD 120 million seawater reverse osmosis desalination plant will provide 100 million liters per day of potable water to the people of Chennai, India. MECON prepared structural, piping, and equipment general arrangement drawings on a tight schedule. The project required complex pipe routing, with multiple engineering disciplines involved in the integration of structural, piping, and equipment designs.

MECON performed 3D modeling using the well-defined and properly structured piping component library in AutoPLANT Piping, and the extensive equipment library in AutoPLANT Equipment. The resulting 3D model was used for stress analysis in AutoPIPE. AutoPLANT and Structural Modeler produced the structural arrangement drawings, and Bentley Navigator facilitated visualization of the integrated 3D model and elimination of interferences.

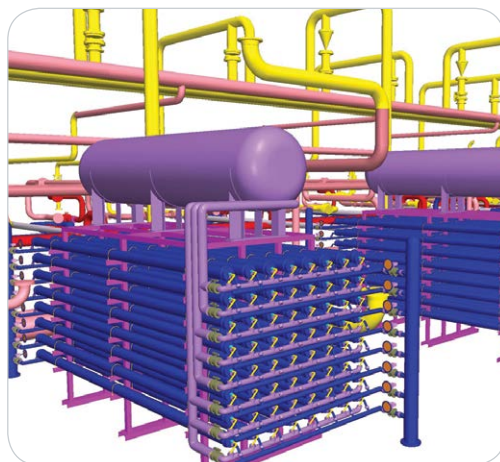
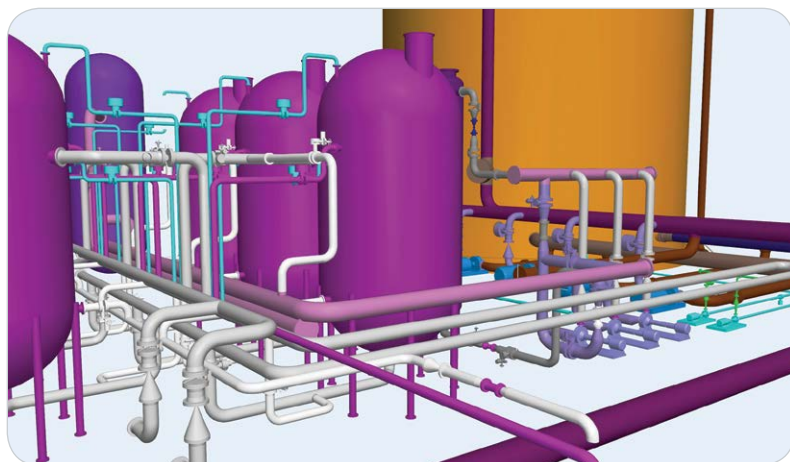

The Walsh Group/Archer Western Contractors

Alvarado Water Treatment Plant Expansion

San Diego, California, United States

The Alvarado Water Treatment Plant is one of three facilities that supplies San Diego, California, with drinking water. In Phase IV of the expansion project, Archer Western Contractors is installing a new ozone system that will increase the output from 120 to 200 million gallons per day. The USD 65 million project includes designing a 14,000-cubic-yard concrete structure, purchasing and installing the ozone system, and all ancillary equipment and site work.

Archer used MicroStation, PlantSpace, AutoPIPE, and Bentley Navigator to convert the designers' 2D documents into 3D models to coordinate all systems, verify the design, and collaborate with subcontractors and vendors. An accurate model with structural, mechanical, electrical, piping, and equipment details helped prevent conflicts, enhance constructability, and forecast equipment issues.

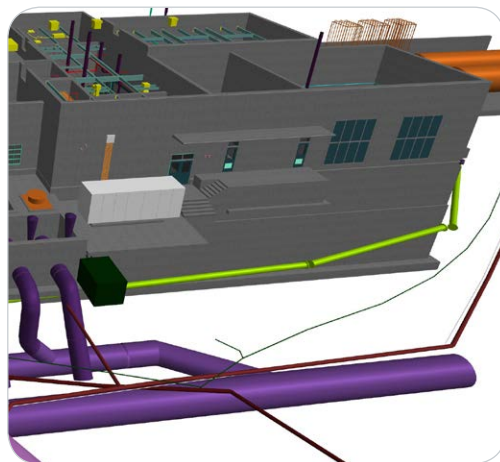
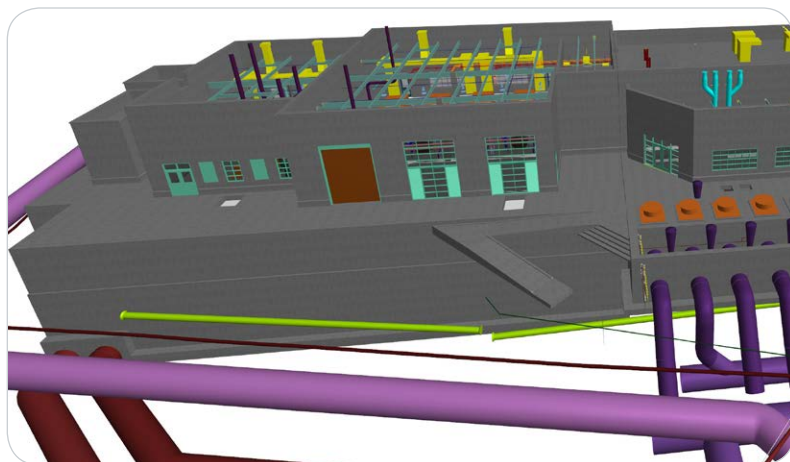

INDEX – ALPHABETICAL BY ORGANIZATION

ORGANIZATION NAME	PROJECT NAME	PAGE
Ausenco Engineers Pvt. Limited (Ausenco Sandwell)	Continuous Polymerization Plant	20
BashNIPIneft	Trebs Oil Field: Central Collection Point	20
F CNGS Engineering	Central Process Platform – V. Filanovsky Oil Field	4
Control Process S.A.	LMG CHP Plant (Part of Gas and Oil Mine)	12
Doosan Heavy Industries & Construction Co., Ltd.	Cebu Coal-Fired Power Plant (100MWx2)	12
Energotechnika Projekt Sp. z o.o.	EC Zeran Modernization	13
Energotechnika Projekt Sp. z o.o.	Imos Gdynia	13
Energotechnika Projekt Sp. z o.o.	IP Kwidzyn Power Plant Expansion	14
Fabricom GDF SUEZ	SITA Re-Energy Bavaro Project	14
F GE Water	Lanxess India – Thermal Zero Liquid Discharge Wastewater Treatment Plant	28
GE Water & Process Technologies	HERO Ultra Pure Water Systems	26
GE Water & Process Technologies	Municipal Series – RO Systems	28
Giprovostokneft	Model for an Estimation of the Intense-deformed Condition of Piping Reservoir Park	21
GMI S.A. Ingenieros Consultores	Fresh Water, Wastewater, Tailing, Reclaimed Water, and Seepage Systems Engineering	29
GMI S.A. Ingenieros Consultores	Potable Water Treatment Plant	29
Kavin Engineering and Service Private Limited	FPU JOKOTOLE	21
KEPCO Engineering & Construction Company Inc.	Yonghung Thermal Power Plant Units 3 & 4	15
Knowsley SK	Offshore Production Platform Deluge Skid	4
Koksoprojekt S. z o.o.	Plant for Deacidification and Ammonia Desorption	8
Larsen & Toubro Limited	Ammonia Plant Feedstock Changeover Project	22
F Larsen & Toubro Limited	Gas Recovery and Injection Project	22
MECON Limited	100 MLD SWRO Desalination Plant	30
NK Rosneft–NTC	VNK1	8
Petrochim Engineering	Crystalliser Disk Regenerativ	9
Projenia S.r.l.	6th of October Power Plant	15
Projenia S.r.l.	Marcinelle CCGT Power Plant	16
F PT. Inti Karya Persada Teknik	Betara Complex Development Project	23
RNZ Pegasus Asia Pacific Sdn. Bhd.	Pipeline and Riser Detailed Design Engineering	5
SR F Shaw Power Group	Virginia City Hybrid Energy Center	16
The Walsh Group/Archer Western Contractors	Alvarado Water Treatment Plant Expansion	30
Ukratnafta	Unit of Additional Reactor	9
United Convery Corporation (India) Pvt. Ltd.	Fly Ash Handling Project	17
W Zeton Inc.	Modular GTL Commercial Demonstration Plant	23

WINNER
W

FINALIST
F

SPECIAL RECOGNITION WINNER
SR

SR



Recognizing the critical importance of being a good corporate citizen, Bentley is uncompromisingly committed to supporting ecological sustainability. This support goes beyond the stewardship of environmental resources to include investment in strategic educational and training initiatives that foster a workforce of skilled infrastructure professionals capable of meeting the world's growing sustainability challenges.

www.bentley.com

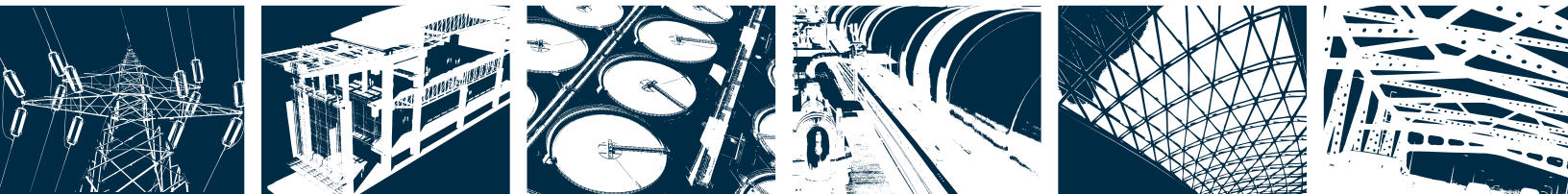

Corporate Headquarters

685 Stockton Drive • Exton, PA 19341 • United States
1-800-BENTLEY (1-800-236-8539) • Outside the United States +1 610-458-5000

Bentley EMEA

2nd Floor • Block 2, Park Place • Upper Hatch Street • Dublin 2 • Ireland • +353 1 436 4600

Bentley Asia

Unit 1402-06, Tower 1 • China Central Place, Beijing 100025 • China • +86 10 5929 7000



© 2014 Bentley Systems, Incorporated

5085 0114